

Axle Shafts - Front - Hummer H2

IDENTIFICATION

MODEL IDENTIFICATION

Body Code ⁽¹⁾	Model
"N"	Hummer H2
(1) Vehicle body code is 5th character of VIN.	

DESCRIPTION & OPERATION

AXLE SHAFTS

Front axle shafts are flexible assemblies which consist of the following components:

- Front constant velocity outer joint.
- Front tri-pot inner joint.
- The front axle shaft connects the tri-pot joint and the constant velocity joint.
- The tri-pot joint is completely flexible, and moves with an in and out motion.
- The constant velocity joint is flexible but can not move in and out.

The axle shaft is a balanced shaft that transmits rotational force from the front differential to the front wheels when the transfer case is engaged. The axle shaft is mounted to the front differential by bolting the flange of the axle shaft to the flange on the inner output shaft of the front differential. The other end of the axle shaft is splined to fit into and drive the hub assembly when the transfer case is engaged. The tri-pot joint and constant velocity joint on the axle shaft allows the shaft to be flexible to move with the suspension travel of the vehicle.

COMPONENT LOCATIONS

To identify and locate axle shaft components, see **Fig. 1** for views of axle shafts.

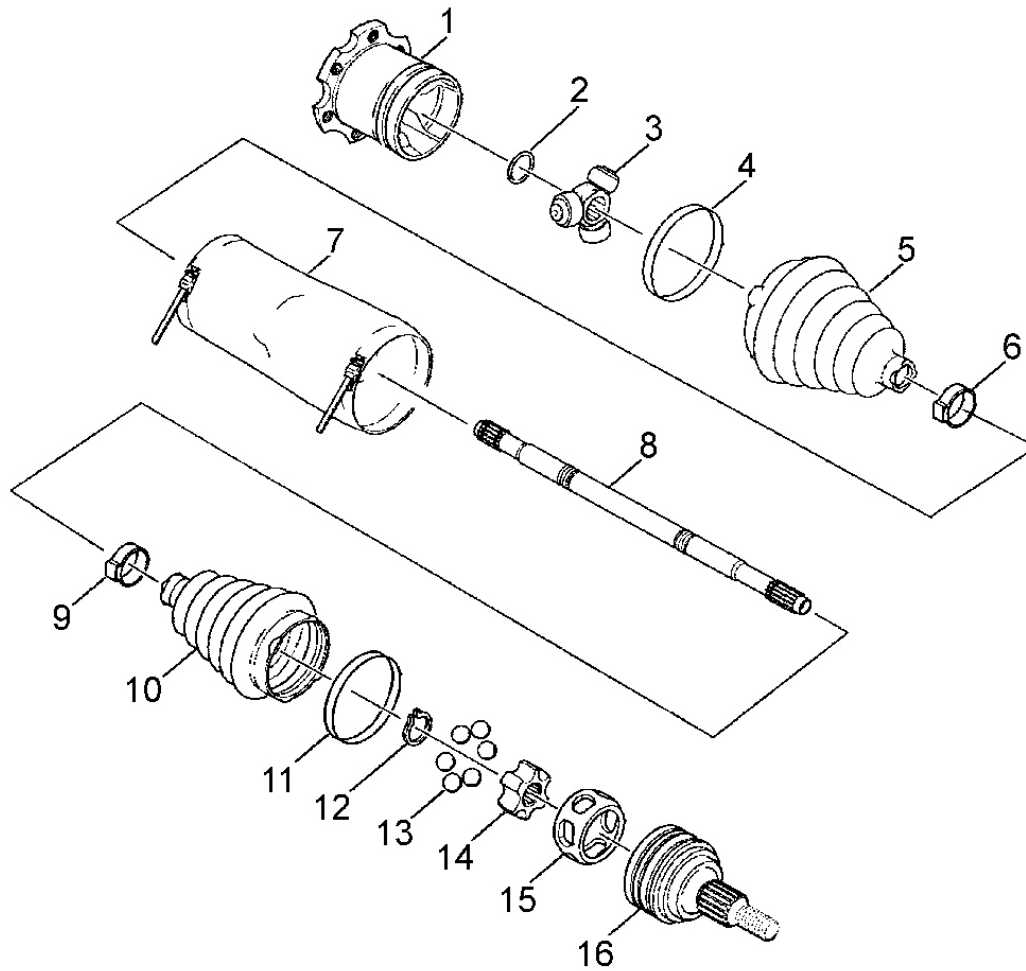

- | | |
|------------------------------------|-------------------------------|
| 1. Tripot Housing Assembly | 9. Small Boot Retaining Clamp |
| 2. Spacer Ring | 10. CV Joint Boot |
| 3. Tripot Joint Spider Assembly | 11. Swage Ring |
| 4. Swage Ring | 12. Race Retaining Ring |
| 5. Tripot Joint Boot | 13. Ball |
| 6. Small Boot Retaining Clamp | 14. CV Joint Inner Race |
| 7. Halfshaft Boot Cover (Optional) | 15. CV Joint Cage |
| 8. Halfshaft Bar | 16. CV Joint Outer Race |

G00330051

Fig. 1: Exploded View Of Axle Shaft Assembly
Courtesy of GENERAL MOTORS CORP.

TRUBLE SHOOTING

www.4x4us.net

www.4x4us.net

DIAGNOSTIC STARTING POINT - AXLE SHAFTS

Begin the system diagnosis by reviewing the system **DESCRIPTION & OPERATION**. Reviewing the Description and Operation will help you to determine the correct symptom diagnostic procedure when a malfunction exists. Reviewing the Description and Operation information will also help you determine if the condition described by the customer is normal operation. See **SYMPTOMS - AXLE SHAFTS** in order to identify the correct procedure for diagnosing the system and where the procedure is located.

DIAGNOSTIC STARTING POINT - VIBRATION DIAGNOSIS AND CORRECTION

See **DIAGNOSTIC STARTING POINT** in VIBRATION/NOISE/LEAKS - DRIVETRAIN article in GENERAL INFORMATION.

SYMPTOMS - AXLE SHAFTS

Before beginning diagnosis, review the system description and operation in order to familiarize yourself with the system function. See **DESCRIPTION & OPERATION**.

Classifying The Symptom

Axle shaft symptoms can usually be classified into the following categories, Noises and Vibration:

- For noise concerns, see **TROUBLE SHOOTING** in VIBRATION/NOISE/LEAKS - DRIVETRAIN article in GENERAL INFORMATION.
- For vibration concerns, see **DIAGNOSTIC STARTING POINT** in VIBRATION/NOISE/LEAKS - DRIVETRAIN article in GENERAL INFORMATION.

Visual/Physical Inspection

- Inspect the system for aftermarket devices which could affect the operation of the axle shaft.
- Inspect the easily accessible or visible system components for obvious damage or conditions which could cause the symptom.

SYMPTOMS - VIBRATION DIAGNOSIS AND CORRECTION

See **SYMPTOMS** in VIBRATION/NOISE/LEAKS - DRIVETRAIN article in GENERAL INFORMATION.

REMOVAL & INSTALLATION

CAUTION: When battery is disconnected, vehicle computer and memory systems may lose memory data. Driveability problems may exist until computer systems have completed a relearn cycle. Before disconnecting battery, see appropriate **COMPUTER RELEARN PROCEDURES** article in GENERAL INFORMATION.

NOTE: Use the correct fastener in the correct location. Replacement fasteners must be the correct part number for that application. Fasteners requiring replacement or

www.4x4us.net fasteners requiring the use of thread locking compound or sealant are identified in the service procedure. DO NOT use paints, lubricants, or corrosion inhibitors on fasteners or fastener joint surfaces unless specified. These coatings affect fastener torque and joint clamping force and may damage the fastener. Use the correct tightening sequence and specifications when installing fasteners in order to avoid damage to parts and systems.

AXLE SHAFTS

Removal

NOTE: Tool required: Axle Remover (J-45859).

1. Raise the vehicle. Remove the wheel and tire assembly. Remove the axle shaft center cap, if equipped.
2. Insert a drift or a large screwdriver through the brake caliper into one of the brake rotor vanes in order to prevent the axle shaft from turning. See **Fig. 2** . Remove the nut and the washer from the hub. DO NOT reuse the nut. A NEW nut must be used when installing the axle shaft.
3. Using the Axle Remover (J-45859) or equivalent, press the axle shaft from the hub. See **Fig. 3** . Remove the six bolts securing the axle shaft inboard flange to the output shaft flange. See **Fig. 4** . Remove the drift from the rotor.
4. Disconnect the stabilizer shaft link from the lower control arm. Wrap shop towels around both the inner and the outer axle shaft boots in order to avoid damage to the boots during removal. Pull the axle shaft through the lower control arm opening.

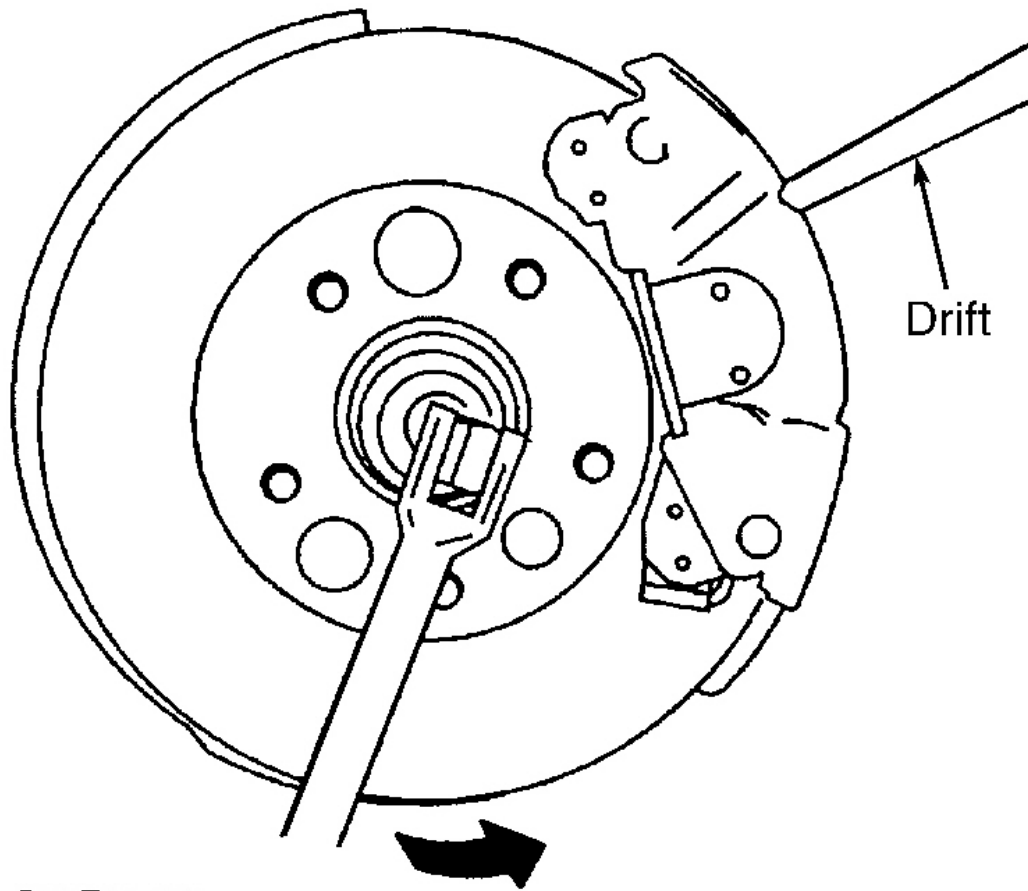

G99E50173

Fig. 2: Removing Axle Shaft Nut & Washer
Courtesy of GENERAL MOTORS CORP.

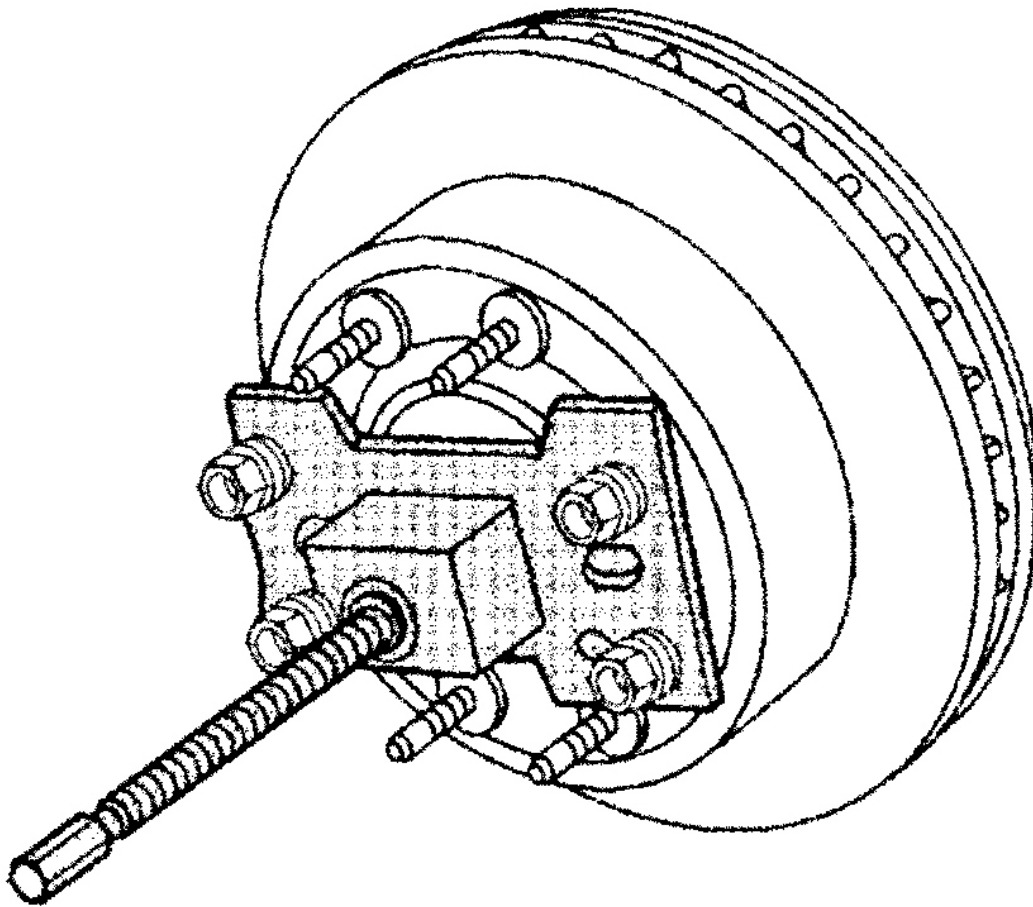

G00329158

Fig. 3: Pressing Axle Shaft From Hub
Courtesy of GENERAL MOTORS CORP.

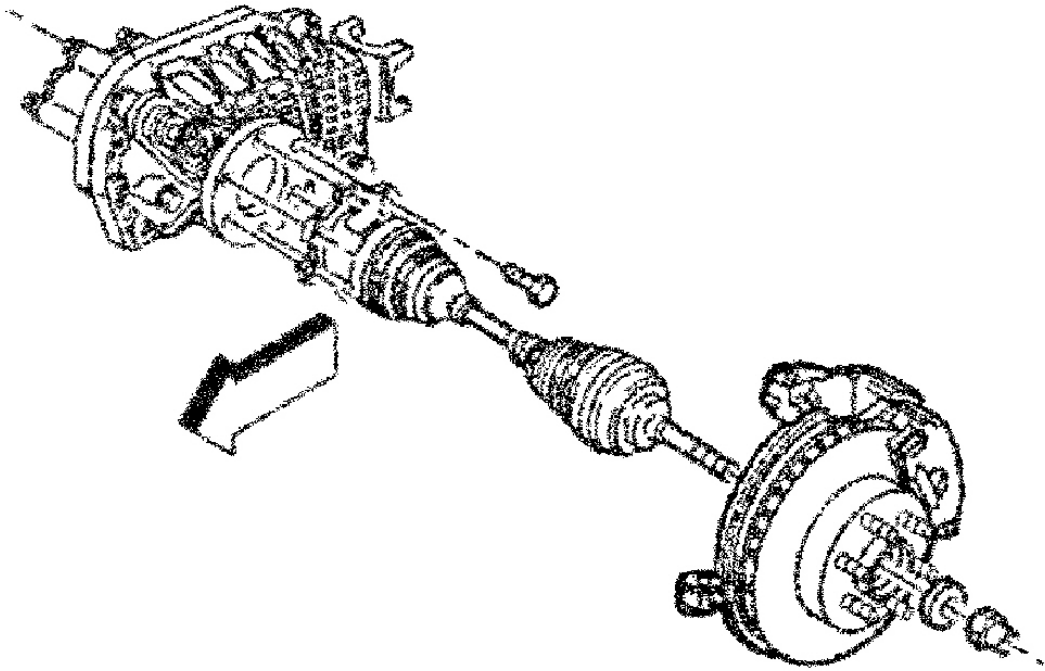

G00329159

Fig. 4: Removing/Installing Axle Shaft Assembly
Courtesy of GENERAL MOTORS CORP.

Installation

NOTE: Clean the steering knuckle and the axle shaft splines and threads. These areas must be dry and free of grease, dirt, and contamination.

NOTE: Use only a genuine GM(R) front axle shaft nut. Installation of anything but an OEM front axle shaft nut could cause damage to the vehicle.

1. Wrap shop towels around both the inner and the outer axle shaft boots in order to avoid damage to the boots during installation.
- 2.

CAUTION: Clean the steering knuckle and the axle shaft splines and threads. These areas must be dry and free of grease, dirt, and contamination.

Insert the axle shaft splined shank into the knuckle hub. Install the washer and the new hub nut to the axle shaft. DO NOT tighten the new hub nut at this time.

3. Attach the axle shaft inboard flange to the output shaft flange using the inboard flange bolts. See **Fig. 4**. Insert a drift or a large screwdriver through the brake caliper into one of the brake rotor vanes in order to

prevent the axle shaft from turning. Tighten the inboard flange bolts to specification. See **TORQUE SPECIFICATIONS**. Tighten the hub nut to specification.

4. Remove the drift from the rotor. Install the axle shaft center cap, if equipped. Connect the stabilizer shaft link to the lower control arm.
5. Install the wheel and tire assembly. Tighten wheel lug nuts to specification. Lower the vehicle.

OVERHAUL

INNER JOINT & SEAL

CAUTION: Use caution when using the hand grinder by the tripot housing.

NOTE: Required Tools: Axle Shaft Seal Clamp Pliers (J-35910), Axle Shaft Clamp Swage Tool (J-36652) and Axle Swage Tool (J-36652-98).

Disassembly

1. Use a hand grinder in order to cut through the swage ring. Remove the tripot housing from the axle shaft. See **Fig. 5**.
2. Wipe the grease off of the housing. Thoroughly degrease the tripot housing. Allow the tripot housing to dry prior to assembly. Using side cutters, remove the small boot retaining clamp.
3. Remove spacer ring, the tripot spider assembly and the tripot boot from the axle shaft bar. See **Fig. 6**. Clean the axle shaft bar. Use a wire brush in order to remove any rust in the seal mounting area (grooves).
4. Inspect the needle rollers, needle bearings, and trunnion. Inspect the tripot housing for unusual wear, cracks, or other damage. Replace any damaged parts with the appropriate service kit as necessary.

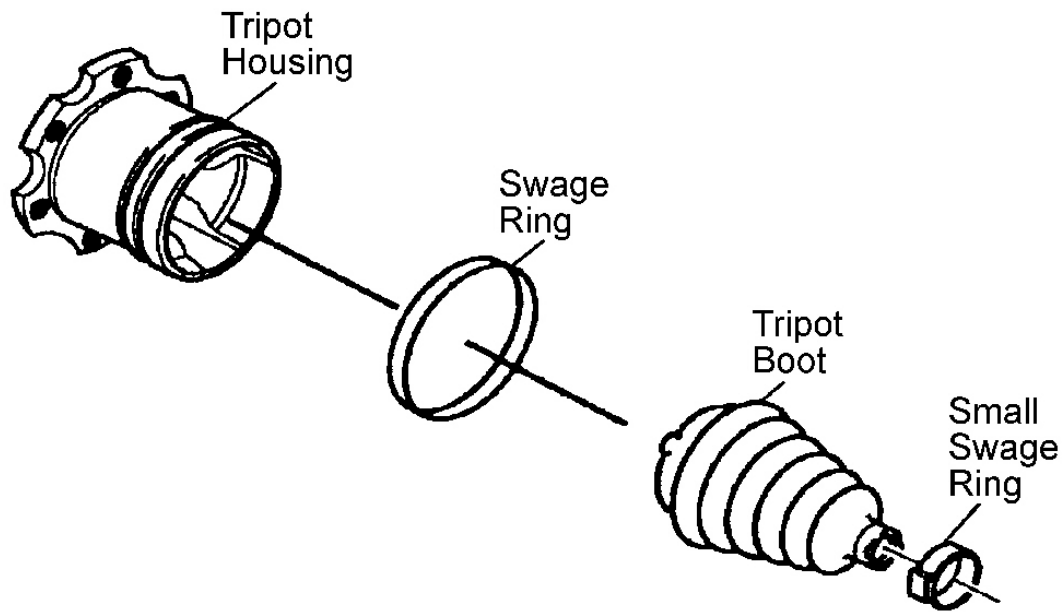

G00329160

Fig. 5: Removing/Installing Tripot Housing Boot
Courtesy of GENERAL MOTORS CORP.

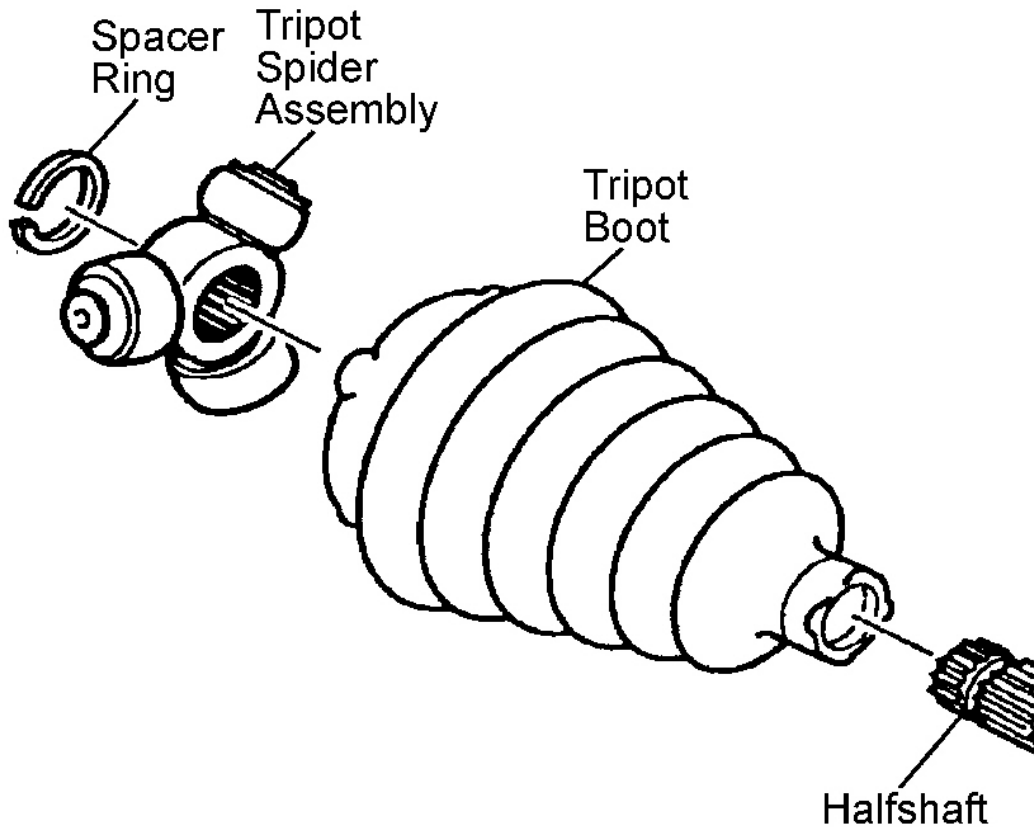

G00329161

Fig. 6: Identifying Spacer Ring, Tripot Spider Assembly & Tripot Boot
 Courtesy of GENERAL MOTORS CORP.

Reassembly

1. Place the new small seal clamp onto the small end of the joint seal. Compress the joint seal and small seal clamp onto the axle shaft bar. Position the small end of the joint seal into the joint seal groove on the axle shaft bar. See **Fig. 7**.
2. Secure the small seal clamp with Axle Shaft Seal Clamp Pliers, or equivalent, a breaker bar, and a torque wrench. See **Fig. 8**. Tighten the small seal clamp to specifications. See **TORQUE SPECIFICATIONS**. Inspect the gap dimension on the clamp ear. Continue tightening until the gap dimension is reached. Gap dimension is .085" (2.15 mm).
3. Assemble the tripot joint with the convolute retainer in the correct position, as illustrated. See **Fig. 9**. Install the convolute retainer tool over the inboard joint seal, being sure to capture 2-4 convolutions.
4. Install the tripot spider assembly onto the axle shaft bar. See **Fig. 6**. Install the spacer ring in the groove at the end of the axle shaft bar. Pack the tripot seal and the tripot housing with the grease supplied in the kit. The amount of grease supplied in this kit has been pre-measured for this application.

5. Assemble the tripod housing and the tripod seal using the following procedure: www.4x4us.net
- A. Pinch the swage ring slightly by hand in order to distort it into an oval shape.
 - B. Slide the distorted swage ring over the large diameter of the seal.
 - C. Place the tripod housing over the spider assembly.
 - D. Install the seal onto the tripod housing. See **Fig. 5**.
 - E. Align the tripod seal, with the swage ring in place, over the flat area on the tripod housing.
6. Assemble the bolts and the support plate to the base of the Axle Swage Tool and secure the base in a vise. See **Fig. 10**.
7. Position the inboard end (tripot end) of the axle shaft assembly into the base of the Axle Swage Tool. Install the top half of the Axle Swage Tool.
8. Align the swage ring and the swage ring clamp. Insert the bolts. Hand tighten the bolts until the bolts are snug. Align the following during this procedure:
- The tripod boot.
 - The tripod housing.
 - The swage ring.
 - Tighten each bolt 180 degrees at a time. Alternate between the bolts until both sides of the top half of the tool touch the bottom half.
 - Loosen the bolts and remove the axle shaft assembly from the tool.
9. Inspect the inboard stroke position using measurement "B". See **Fig. 11**.
10. Remove the convolute retainer tool from the boot.

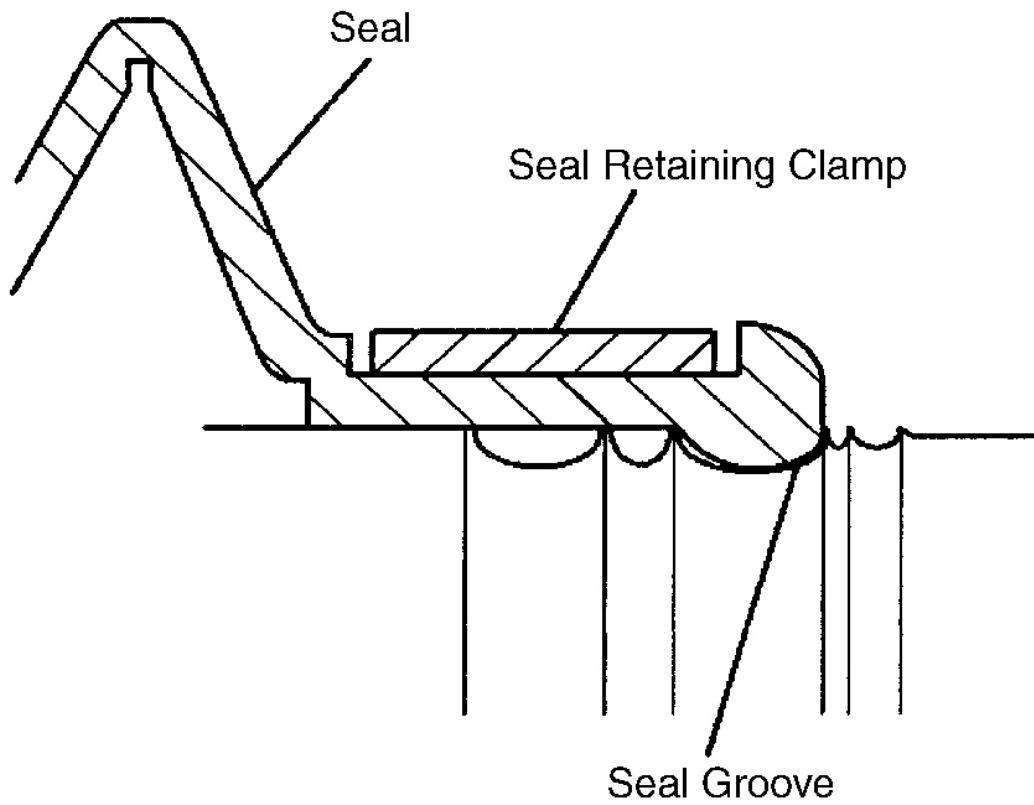

G00307733

Fig. 7: Identifying Correct Orientation Of Joint Seal
Courtesy of GENERAL MOTORS CORP.

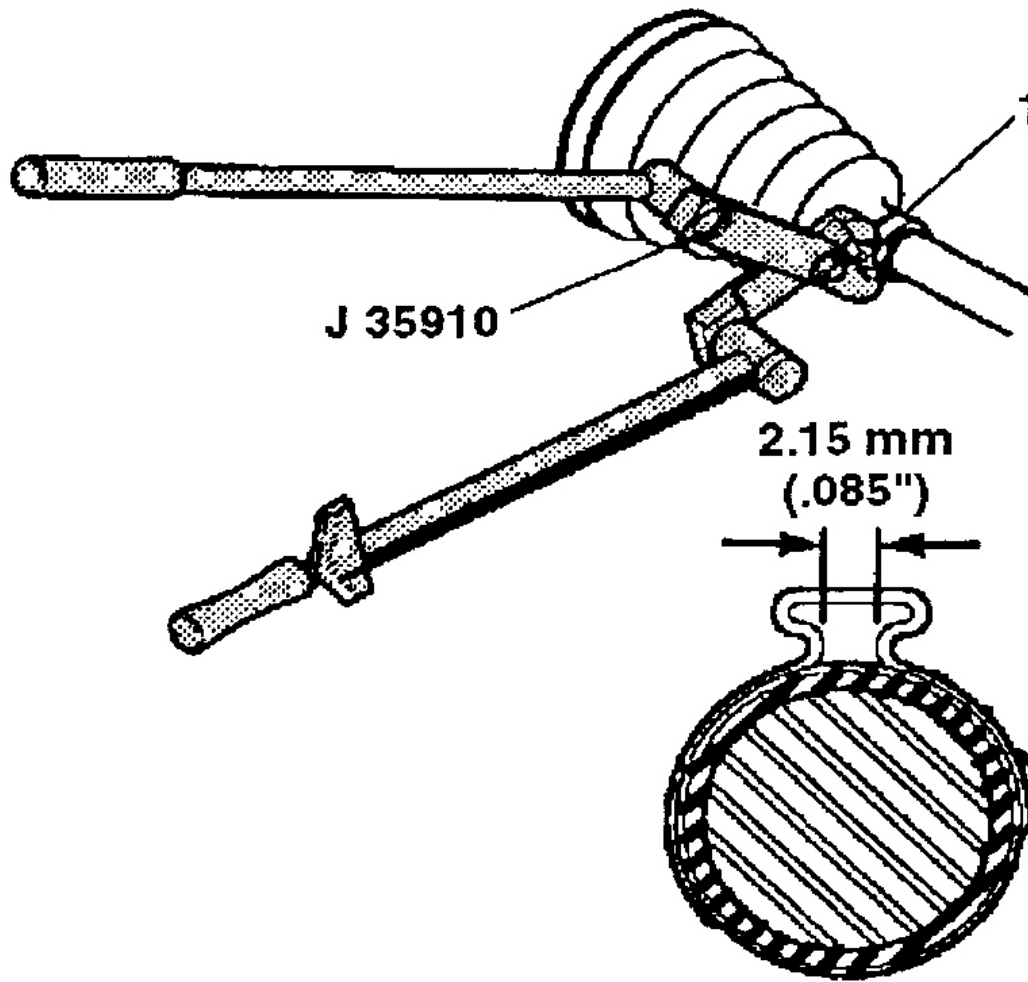

G00329162

Fig. 8: Crimping Inner & Outer Joint Boot Small Clamp
Courtesy of GENERAL MOTORS CORP.

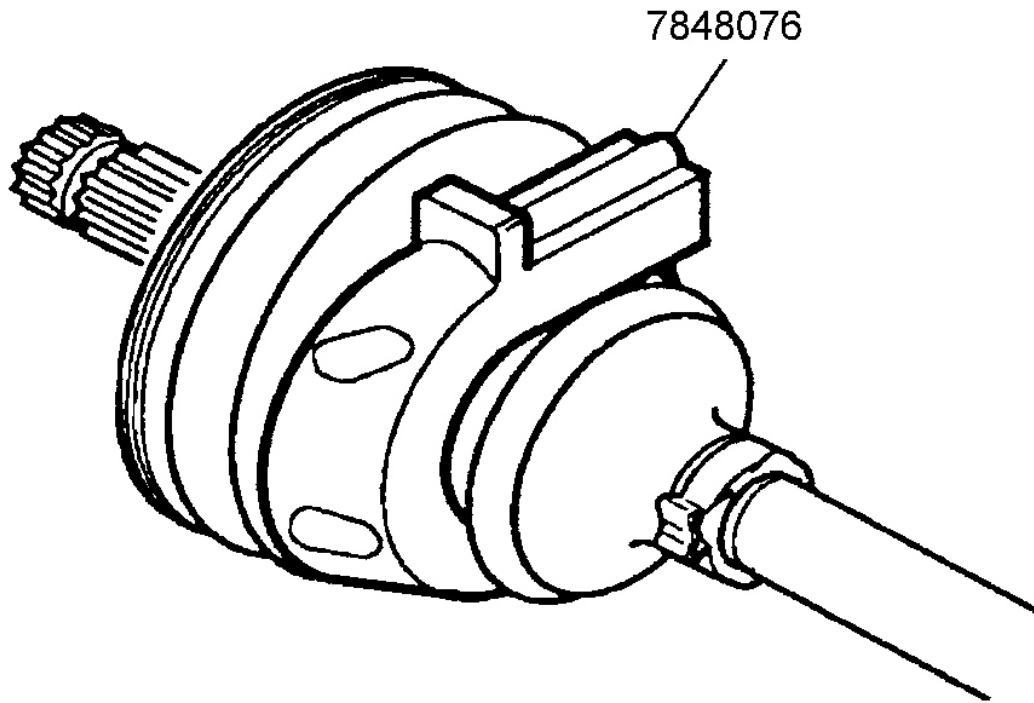

G00330059

Fig. 9: Positioning Convolute Retainer
Courtesy of GENERAL MOTORS CORP.

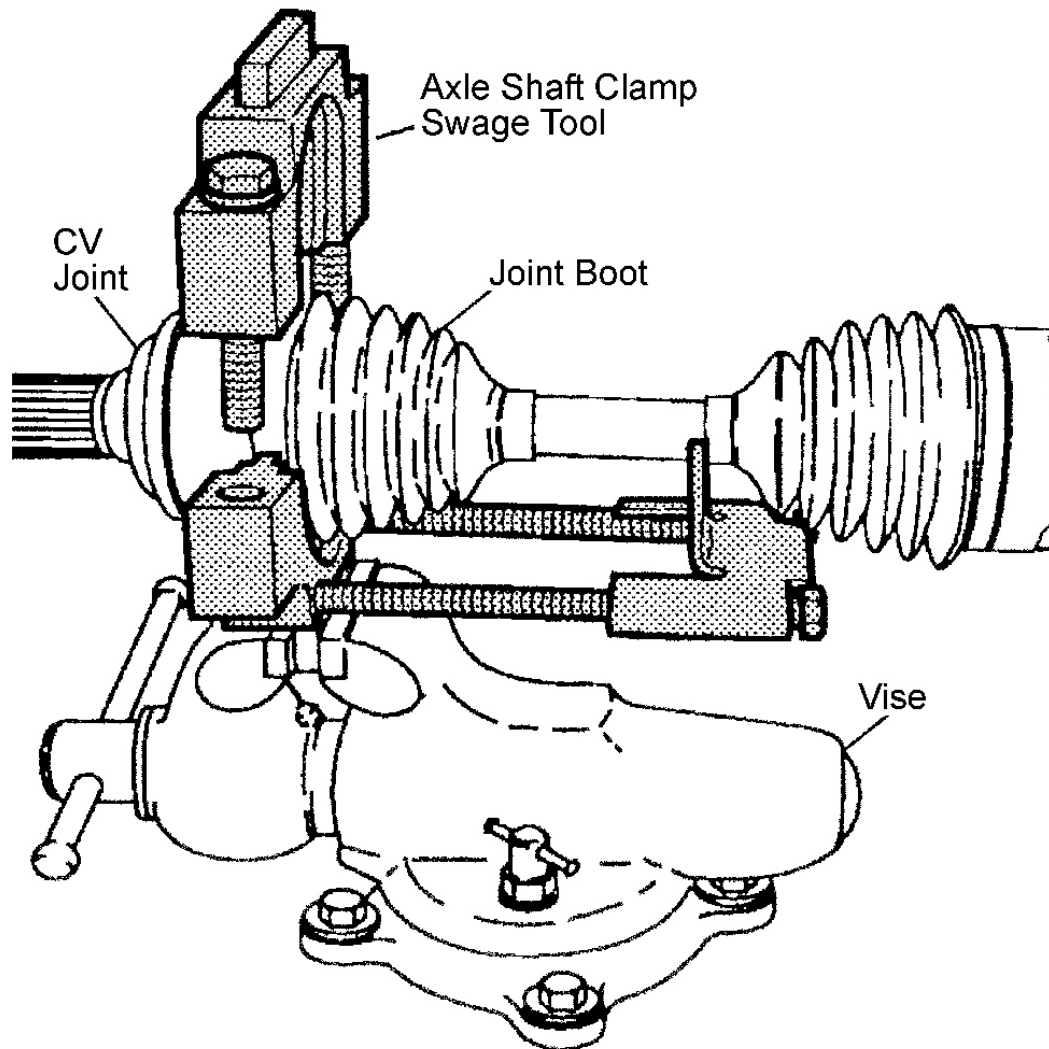

G00330645

Fig. 10: Mounting Axle Shaft In Axle Shaft Clamp Swage (Typical)
Courtesy of GENERAL MOTORS CORP.

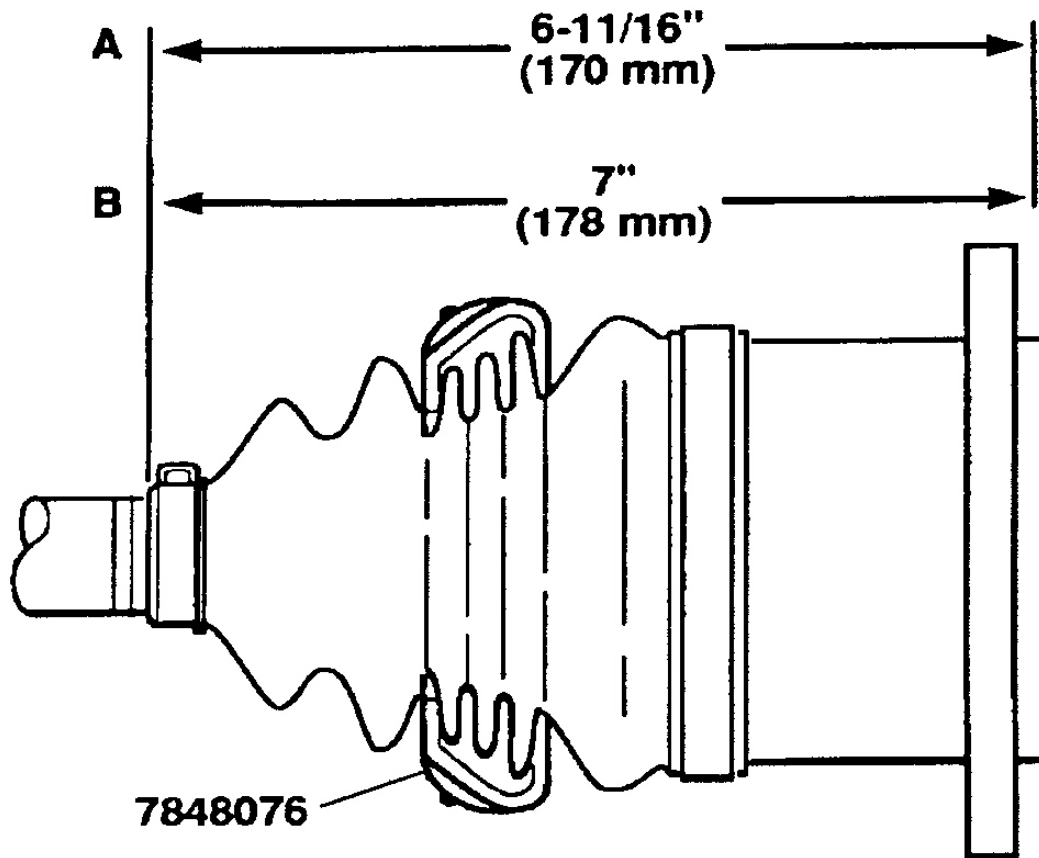

G00330060

Fig. 11: Inspecting Inboard Stroke Position
 Courtesy of GENERAL MOTORS CORP.

OUTER JOINT & SEAL

NOTE: Required Tools: Axle Shaft Seal Clamp Pliers (J-35910), Axle Shaft Clamp Swage Tool (J-36652) and Snap Ring Pliers (J-8059).

Disassembly

1. Use a hand grinder to cut through the swage ring. Use side cutters to cut off the small boot clamp. See **Fig. 12** . Slide the boot down the axle shaft bar and away from the CV joint outer race. Wipe all grease away from the face of the CV joint. Find the axle shaft bar retaining snap ring, which is located in the inner race.
2. Spread the snap ring ears apart using Snap Ring Pliers (or equivalent). Pull the CV joint and the CV joint boot from the axle shaft bar. Discard the old CV joint boot.
3. Place a brass drift against the CV joint cage. Tap gently on the brass drift with a hammer in order to tilt

Remove the first chrome alloy ball when the CV joint cage tilts. Tilt the CV joint cage in the opposite direction to remove the opposing chrome alloy ball. See **Fig. 12**. Repeat to remove all six of the balls.

4. Pivot the CV joint cage and the inner race 90 degrees to the center line of the outer race. At the same time, align the cage windows with the lands of the outer race. Lift out the cage and the inner race. See **Fig. 12**.
5. Remove the inner race from the cage by rotating the inner race upward. Clean the inner and outer race assemblies, the CV joint cage and the chrome alloy balls thoroughly with cleaning solvent. Remove all traces of old grease and any contaminants.
6. Dry all the parts. Check the CV joint assembly for unusual wear, cracks, or other damage. Replace any damaged parts. Clean the axle shaft bar. Use a wire brush to remove any rust in the seal mounting area (grooves).

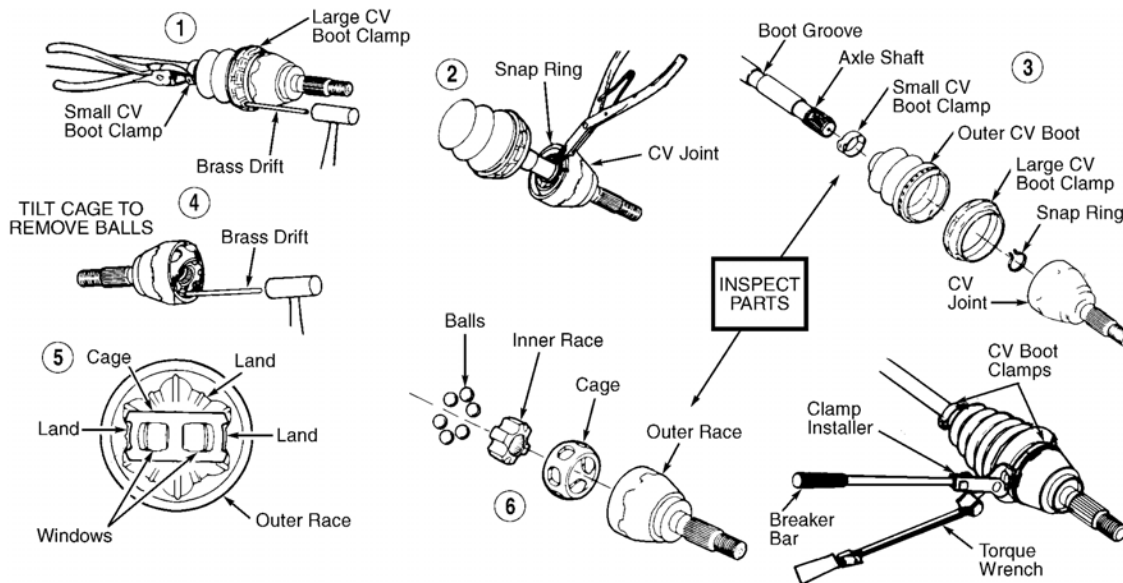

G95H13406

Fig. 12: Identifying Outer CV Joint (Rzeppa Type) Components
Courtesy of GENERAL MOTORS CORP.

Reassembly

1. Inspect all of the parts for unusual wear, cracks, or other damage. Replace the CV joint assembly if necessary. Put a light coat of the recommended grease on the inner and the outer race grooves. See **Fig. 12**.
2. Hold the inner race at 90 degrees to the centerline of the cage. Align the lands of the inner race with the windows of the cage. Insert the inner race into the cage, by rotating the inner race downward. See **Fig. 12**.
3. Insert the cage and inner race into the outer race. Place a brass drift against the CV joint cage. Tap gently on the brass drift with a hammer in order to tilt the cage. Install the first chrome alloy ball when the CV joint cage tilts. Tilt the CV joint cage in the opposite direction to install the opposing chrome alloy ball. Repeat this process in order to install all six of the balls.
4. Pack the CV joint boot and the CV joint assembly with the grease supplied in the kit. The amount of

grease supplied in this kit has been pre-measured for this application. Place the new small boot clamp onto the CV joint seal. Slide the CV joint boot onto the axle shaft bar. Position the small end of the CV joint boot into the joint boot groove on the axle shaft bar.

5. Secure the small boot clamp using Axle Shaft Seal Clamp Pliers (or equivalent), a breaker bar, and a torque wrench. Tighten the small clamp to specifications. See **TORQUE SPECIFICATIONS**. See **Fig. 8**. Check the gap dimension on the clamp ear. Continue tightening until the gap dimension is reached. Gap dimension is .085" (2.15 mm).
6. Pinch the new swage ring slightly by hand to distort it into an oval shape. Slide the distorted swage ring over the large diameter of the boot. Pull on the CV joint to verify engagement. Slide the large diameter of the CV joint boot, with the large swage ring in place, over the outside edge of the CV joint outer race.
7. Clamp the CV joint boot tightly to the CV joint outer race with the large swage ring, using the following procedure:
 - A. Mount the base of Axle Shaft Clamp Swage Tool in a vise. See **Fig. 10**.
 - B. Position the CV joint end (outboard end) of the axle shaft assembly in the bottom half of Axle Shaft Clamp Swage Tool.

Align the CV joint boot, the CV joint assembly and the swage ring during this procedure.

8. Install the top half of Axle Shaft Clamp Swage Tool onto the lower half of the tool, over the CV joint boot and the CV joint assembly. Align the swage ring and the swage ring clamp. Insert the bolts into Axle Shaft Clamp Swage Tool. Hand tighten the bolts until the bolts are snug. Tighten each bolt 180 degrees at a time. Alternate between the bolts until both sides of the top half of the Axle Shaft Clamp Swage Tool touch the bottom half of the tool. Loosen the bolts and remove the axle shaft assembly from Axle Shaft Clamp Swage Tool.

TORQUE SPECIFICATIONS

TORQUE SPECIFICATIONS

Application	Ft. Lbs. (N.m)
Hub Nut	173 (235)
Inboard Flange Nuts	58 (79)
Inner & Outer Joint Boot Small Clamp	100 (136)
Oil Pan Skid Plate Retaining Bolts	15 (20)
Stabilizer Shaft Insulator Bracket Bolts	37 (50)
Wheel Lug Nuts	175 (240)
	INCH Lbs. (N.m)
Stabilizer Shaft-To-Lower Control Arm Nut	89 (10)

SPECIAL TOOLS

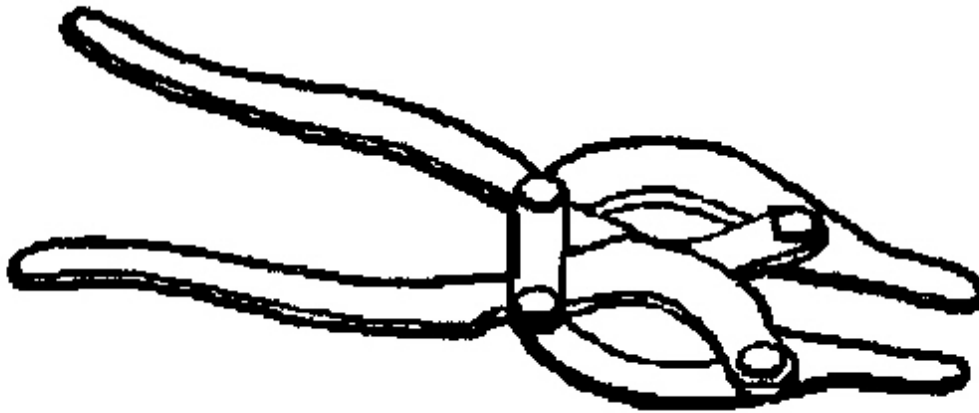

G00330033

Fig. 13: Snap Ring Pliers (J-8059)
Courtesy of GENERAL MOTORS CORP.

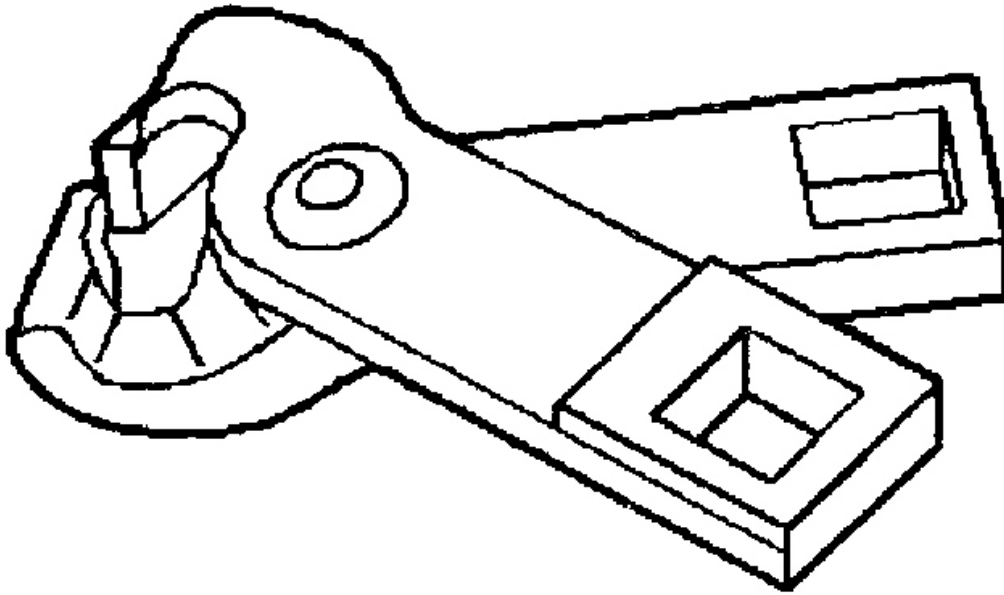

G00330027

Fig. 14: Axle Shaft Seal Clamp Pliers (J-35910)
Courtesy of GENERAL MOTORS CORP.

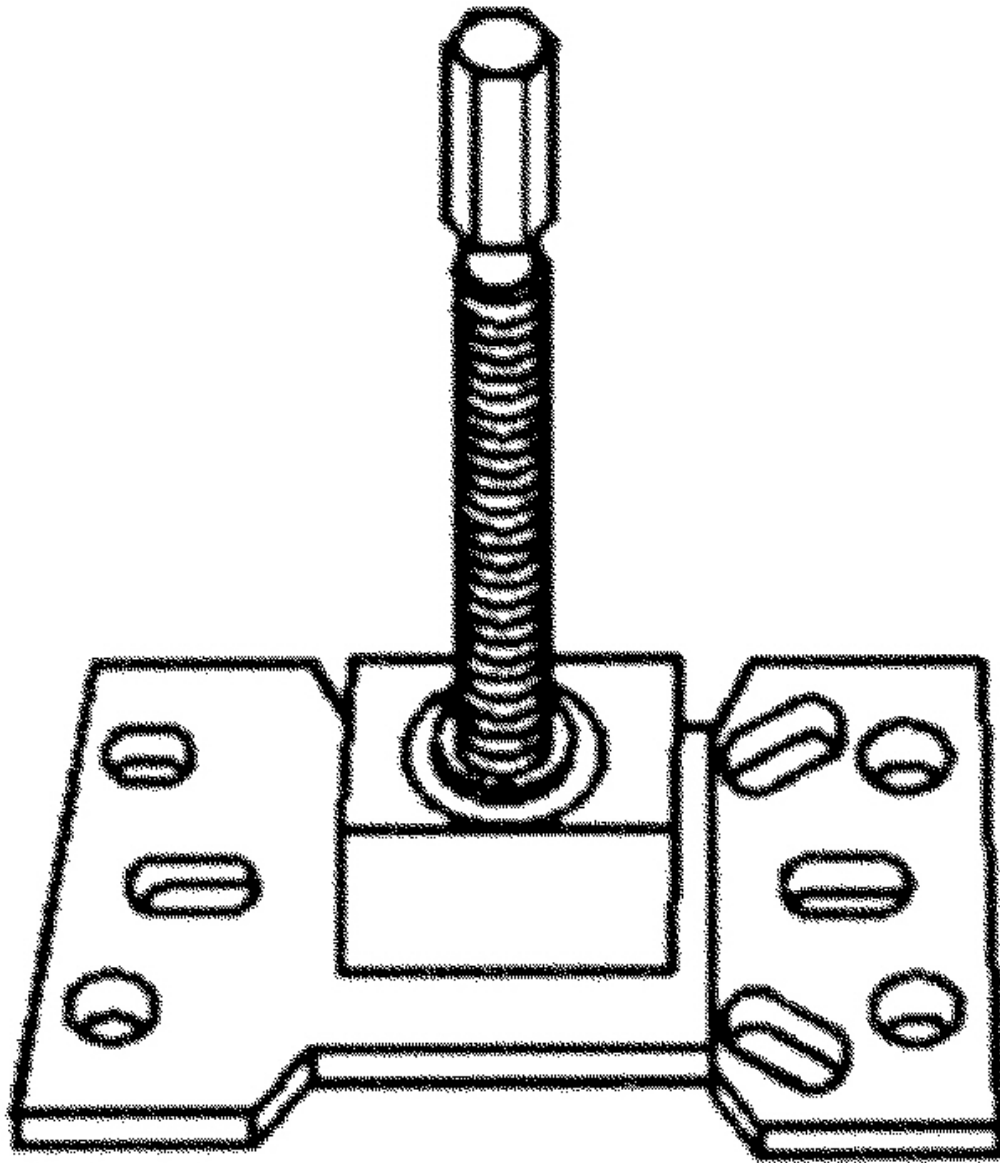

G00330049

Fig. 15: Axle Remover (J-45859)
Courtesy of GENERAL MOTORS CORP.

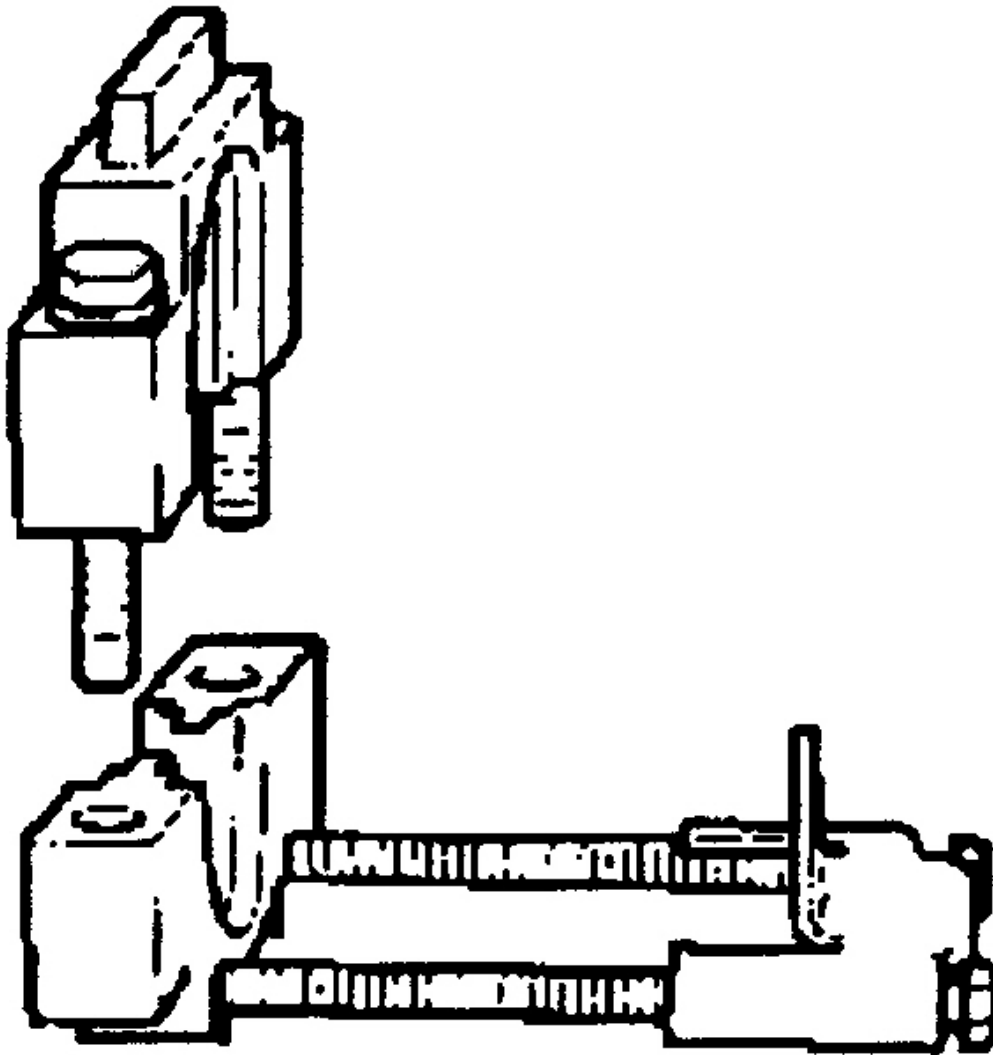

G00330061

Fig. 16: Axle Shaft Clamp Swage Tool (J-36652)
Courtesy of GENERAL MOTORS CORP.

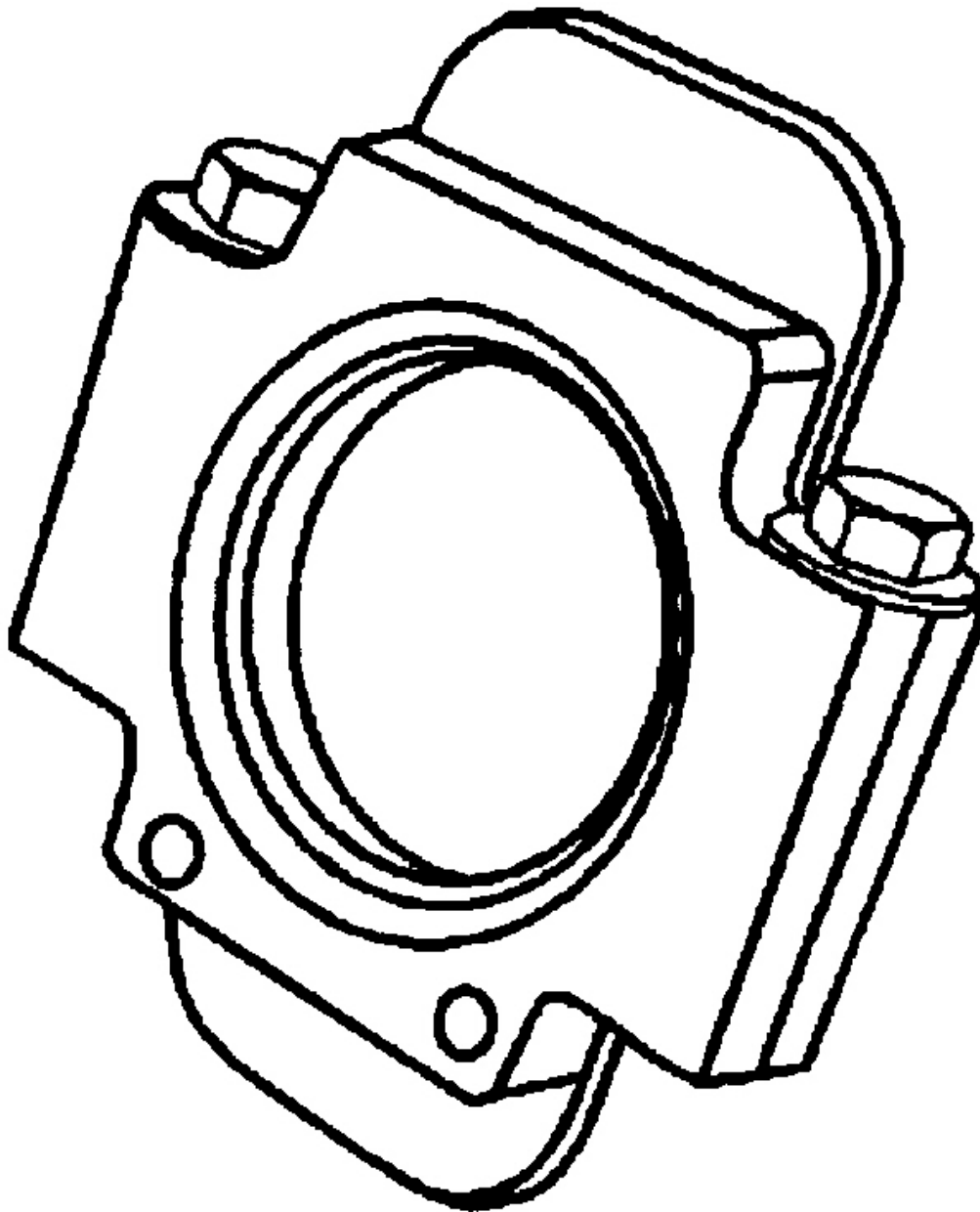

G00330062

Fig. 17: Axle Swage Tool (J-36652-98)
Courtesy of GENERAL MOTORS CORP.
www.4x4us.net