

Engine Cooling - Hummer H2

SPECIFICATIONS**FASTENER TIGHTENING SPECIFICATIONS****Fastener Tightening Specifications**

Application	Specification	
	Metric	English
Air Cleaner Outlet Duct Clamp Screw (4.8L, 5.3L, and 6.0L Engines)	7 N.m	62 lb in
Air Cleaner Outlet Duct Wingnut (4.3L Engine)	3 N.m	27 lb in
Coolant Air Bleed Pipe Stud/Bolt (4.8L, 5.3L, and 6.0L Engines)	12 N.m	106 lb in
Coolant Heater Cord Bolt	8 N.m	71 lb in
Coolant Heater Bolt (4.3L Engine)	2 N.m	18 lb in
Coolant Heater (4.8L, 5.3L, 6.0L Engines)	50 N.m	37 lb ft
Engine Block Coolant Drain Plug (4.3L Engine)	20 N.m	15 lb ft
Engine Coolant Temperature Sensor (6.6L Engine)	33 N.m	24 lb ft
Fan Clutch Bolt	23 N.m	17 lb ft
Fan Clutch Nut	56 N.m	41 lb ft
Fan Shroud Bolt	9 N.m	80 lb in
Fan and Water Pump Pulley Bolt (4.3L Engine)	25 N.m	18 lb ft
Oil Cooler Hose Adapter Bolt (6.0L Engine)	12 N.m	106 lb in
Oil Cooler Hose Bracket Bolt (6.0L Engine)	25 N.m	18 lb ft
Radiator Bolt	25 N.m	18 lb ft
Surge Tank Bolt/Nut	9 N.m	80 lb in
Thermostat Housing Bolt (4.8L, 5.3L, and 6.0L Engines)	15 N.m	11 lb ft
Transmission Control Module (TCM) Cover Bolt	9 N.m	80 lb in
Transmission Control Module (TCM) Electrical Connector Bolt	8 N.m	71 lb in
Water Outlet Stud (4.3L Engine)	25 N.m	18 lb ft
Water Pump Bolt (4.3L Engine)	45 N.m	33 lb ft
Water Pump Bolt (First Pass) (4.8L, 5.3L, and 6.0L Engines)	15 N.m	11 lb ft
Water Pump Bolt (Final Pass) (4.8L, 5.3L, and 6.0L Engines)	30 N.m	22 lb ft

SCHEMATIC AND ROUTING DIAGRAMS**ENGINE COOLING SCHEMATICS**

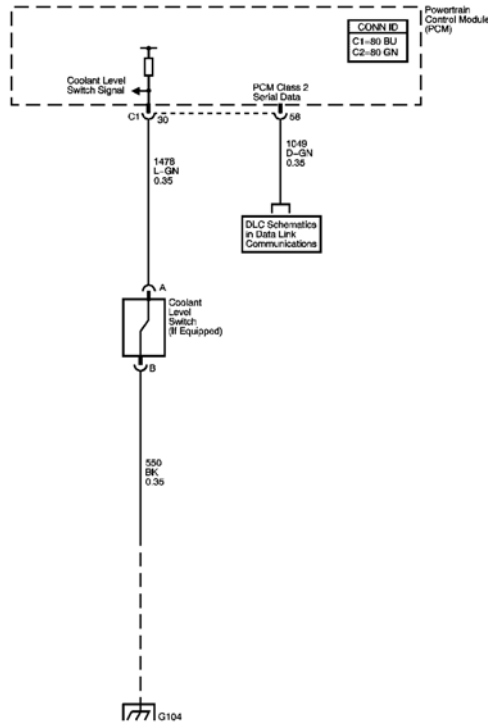

Fig. 1: Engine Cooling Schematics
Courtesy of GENERAL MOTORS CORP.

COMPONENT LOCATOR

COOLING SYSTEM COMPONENT VIEWS

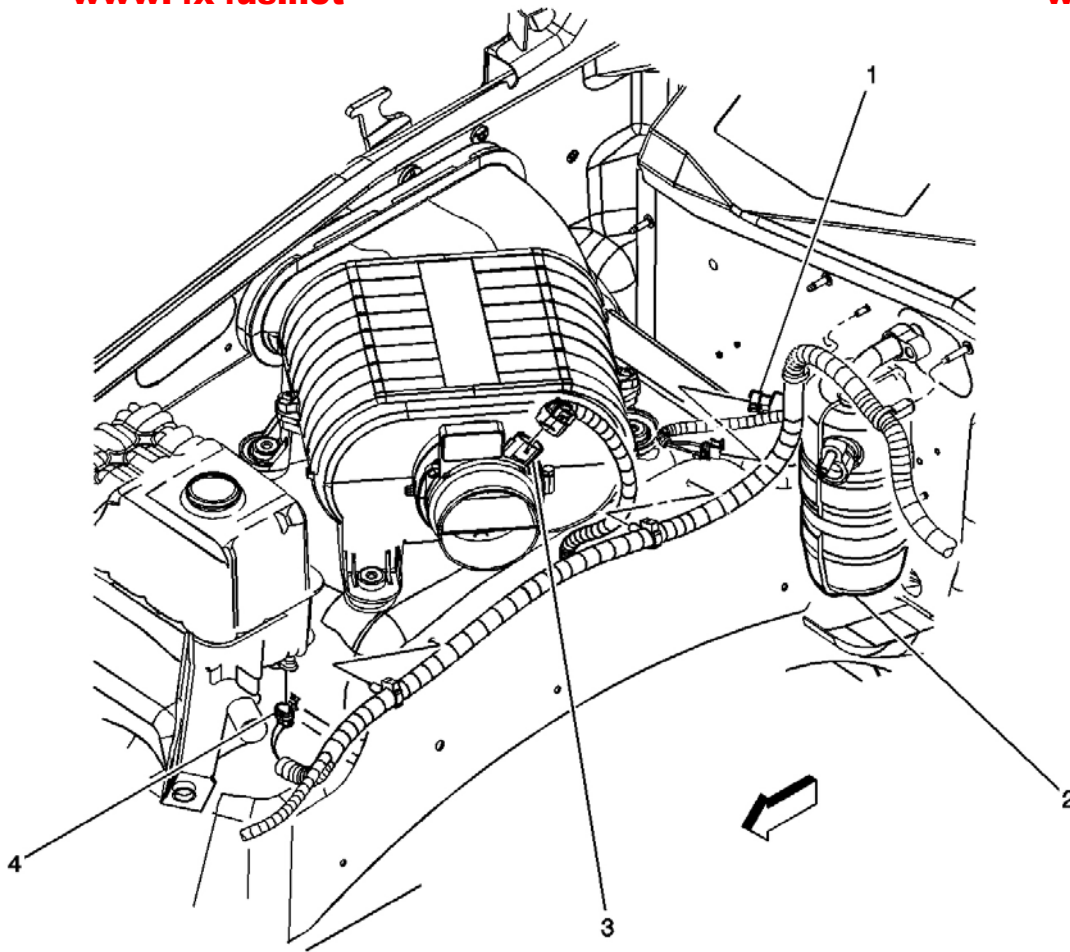

Fig. 2: RR Of Engine Compartment Component Views
Courtesy of GENERAL MOTORS CORP.

Callouts For Fig. 2

Callout	Component Name
1	A/C Low Pressure Switch
2	A/C Accumulator
3	Intake Air Temperature (IAT)/Mass Air Flow (MAF) Sensor
4	Coolant Level Switch (If Equipped)

COOLING SYSTEM CONNECTOR END VIEWS

Coolant Level Terminal Identification Switch (If Equipped)

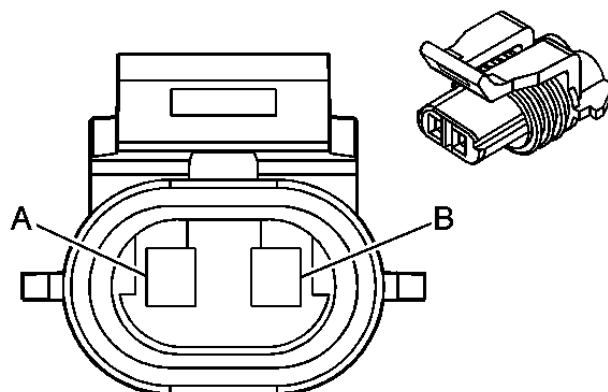

Connector Part Information		<ul style="list-style-type: none"> • 12052644 • 2-Way F Metri-Pack 150 Series Sealed (GY) 	
Pin	Wire Color	Circuit No.	Function
A	L-GN	1478	Coolant Level Switch Signal
B	BK	550	Ground

DIAGNOSTIC INFORMATION AND PROCEDURES

DIAGNOSTIC STARTING POINT - ENGINE COOLING

Begin the system diagnosis with the **Diagnostic System Check - Engine Cooling** . The Diagnostic System Check will provide the following information:

- The identification of the control module(s) which command the system.
- The ability of the control module(s) to communicate through the serial data circuit.
- The identification of any stored diagnostic trouble codes (DTCs) and their status.

The use of the Diagnostic System Check will identify the correct procedure for diagnosing the system and where the procedure is located.

DIAGNOSTIC SYSTEM CHECK - ENGINE COOLING

Test Description

The numbers below refer to the step numbers on the diagnostic table.

3: Lack of communication may be due to a partial malfunction of the class 2 serial data circuit or due to a total malfunction of the class 2 serial data circuit. The specified procedure will determine the particular condition.

4: Determine if the Instrument Cluster or Powertrain Control Modules have set DTCs which may affect Engine Cooling operation are present.

5: The presence of DTCs which begin with "U" indicate some other module is not communicating. The specified procedure will compile all the available information before tests are performed.

Diagnostic System Check - Engine Cooling

Step	Action	Yes	No
1	Did you review a Diagnostic Starting Point-Engine Cooling?	Go to Step 2	Go to Diagnostic Starting Point - Engine Cooling
2	Install a scan tool. Does the scan tool power up?	Go to Step 3	Go to Scan Tool Does Not Power Up in Data Link Communications
3	1. Turn ON the ignition, with the engine OFF. 2. Attempt to establish communication with the following control modules: <ul style="list-style-type: none"> • The instrument cluster • The powertrain control module Does the scan tool communicate with the control modules?	Go to Step 4	Go to Scan Tool Does Not Communicate with Class 2 Device in Data Link Communications
4	Select the powertrain control module display DTCs function on the scan tool. Does the scan tool display any DTCs?	Go to Step 5	Go to Symptoms - Engine Cooling
5	Does the scan tool display any DTCs which begin with a "U"?	Go to Scan Tool Does Not Communicate with Class 2 Device in Data Link Communications	Go to Step 6
6	Does the scan tool display any DTCs that are associated with the Engine Cooling System?	Go to Diagnostic Trouble Code (DTC) List	Go to Diagnostic Trouble Code (DTC) List in Engine Controls - 4.8L, 5.3L, and 6.0L

SCAN TOOL OUTPUT CONTROLS

Instrument Cluster

Scan Tool Output Control	Additional Menu Selection(s)	Description
Special Functions	Help Test	Command the instrument cluster to illuminate all lamps in the cluster
Special Functions	IPC Gauges	Command the instrument cluster to sweep all gauges.

SCAN TOOL DATA LIST

Instrument Panel Cluster (IPC)

Scan Tool Parameter	Data List	Units Displayed	Typical Data Value
Ignition Switch in RUN/Engine running/Automatic Transmission in PARK/Manual Transmission in NEUTRAL/Air Conditioner is OFF			
Displayed Coolant Temp	Data	Celsius (C)/Fahrenheit (F)	87° C (189° F)
Monitored Coolant Temp	Data	Celsius (C)/Fahrenheit (F)	87° C (Fluctuates range 82-93° C) 189° F (Fluctuates range 180-200° F)

6.0L

Scan Tool Parameter	Data List	Units Displayed	Typical Data Value
Ignition Switch in RUN/Engine running/Automatic Transmission in PARK/Manual Transmission in NEUTRAL/Air Conditioner is OFF			
ECT Sensor	Engine Data 1 Engine Data 2	Degrees	87° C (189° F)
Coolant Level Switch	Engine Data 2	Low/OK	OK

SCAN TOOL DATA DEFINITIONS

Coolant Level Switch - Range: Low/OK

This parameter indicates when the engine coolant level is low. The scan tool displays Low when the powertrain control module (PCM) detects the engine coolant level switch is open.

ECT - Range: -40° C to +150° C (-40° F to +302° F)

The PCM applies 5.0 volts to the ECT sensor circuit. The sensor is a thermistor which changes internal resistance as the engine temperature changes. When the sensor is cold (internal resistance high), the PCM senses a high signal voltage and interprets the voltage as a cold engine. As the sensor warms (internal resistance decreases), the voltage signal decreases and the PCM interprets the lower voltage as a warm engine.

Displayed Coolant Temperature - Range: 32-127° C (89-260° F)

This data is the coolant temperature the Instrument Cluster is attempting to display on the coolant temperature gauge. This data may differ from the monitored coolant temperature for a period of time due to filtering. The data may also differ from the monitored coolant temperature when coolant temperature is not in the range of 71-127° C (160-260° F) since the display is limited to these values. If a class 2 communication failure occurs, this data will be at the minimum value of 32° C (89° F).

Monitored Coolant Temperature - Range: 40-215° C (40-419° F)

www.4x4us.net

www.4x4us.net

This data is the clusters measurement of the engine coolant temperature as provided by the PCM on the class 2 serial data line.

DIAGNOSTIC TROUBLE CODE (DTC) LIST

Diagnostic Trouble Code (DTC) List

DTC	Diagnostic Procedure	Module
P1258	<u>DTC P1258</u>	PCM

DTC P1258

Circuit Description

The powertrain control module (PCM) uses the engine coolant temperature (ECT) sensor to monitor the engine for an over temperature condition. This condition occurs when the coolant temperature is above 132° C (270° F). When an over temperature condition is present, DTC P1258 will set. The PCM will disable 2 groups of 4 cylinders by turning OFF the fuel injectors. By switching between the 2 groups of cylinders, the PCM is able to reduce the temperature of the coolant.

Conditions for Running the DTC

- DTCS P0117, P0118, P1114, and P1115 are not active.
- The engine is running.

Conditions for Setting the DTC

The engine coolant temperature is above 132° C (270° F) for 10 seconds or more.

Action Taken When the DTC Sets

- The PCM will illuminate the malfunction indicator Lamp (MIL) during the first trip in which the diagnostic test has been run and failed.
- The PCM will signal the IPC to turn ON the Service Engine Soon indicator.
- The PCM will alternately disable two groups of four cylinders by turning OFF the fuel injectors.
- The PCM will store conditions which were present when the DTC set as Freeze Frame and File Records data.

Conditions for Clearing the MIL/DTC

- The PCM will turn the MIL OFF after 3 consecutive trips that the diagnostic has been run and passed.
- The history DTC will clear after 40 consecutive warm-up cycles have occurred without a malfunction.
- The DTC can be cleared by using the scan tool Clear DTC Information function.

www.4x4us.net

www.4x4us.net

DTC P1258

Step	Action	Yes	No
Connector End View Reference: Cooling System Connector End Views			
1	Was the Diagnostic System Check for Engine Cooling performed?	Go to Step 2	Go to Diagnostic System Check - Engine Cooling
2	Check the engine cooling fan for proper operation. Is the engine cooling fan operative?	Go to Engine Overheating	Go to Symptoms - Engine Cooling

SYMPTOMS - ENGINE COOLING

IMPORTANT: Review the system operation in order to familiarize yourself with the system functions. Refer to Cooling System Description and Operation .

Visual/Physical Inspection

- Inspect for aftermarket devices which could affect the operation of the Cooling System. Refer to Checking Aftermarket Accessories in Wiring Systems.
- Inspect the easily accessible or visible system components for obvious damage or conditions which could cause the symptom.
- Inspect the surge tank reservoir for the proper coolant level.

Intermittent

Faulty electrical connections or wiring may be the cause of intermittent conditions. Refer to Testing for Intermittent Conditions and Poor Connections in Wiring Systems.

Symptom List

Refer to a symptom diagnostic procedure from the following list in order to diagnose the symptom:

- Engine Overheated Indicator Always On
- Engine Coolant Temperature Indicator Always On
- Coolant Heater Inoperative
- Engine Overheating
- Loss of Coolant
- Thermostat Diagnosis
- Engine Fails To Reach Normal Operating Temperature
- Fan Clutch Diagnosis
- Low Engine Coolant Indicator Always On

Engine Overheated Indicator Always On

Step	Action	Yes	No
Connector End View Reference: Engine Cooling Schematics DEFINITION: One of the following engine coolant temperature indicators is always On: Engine Coolant, Engine Coolant Hot/Idle Engine, Engine Hot-AC Off, Engine Overheated/Stop Engine.			
1	Did you perform the Engine Cooling Diagnostic System Check?	Go to Step 2	Go To Diagnostic System Check - Engine Cooling
2	Start the engine. Does the Engine Coolant Temperature indicator illuminate?	Go to Step 3	Go to Testing for Intermittent Conditions and Poor Connections in Wiring Systems
3	1. Install a scan tool. 2. With the scan tool, observe the engine coolant temperature parameter in the powertrain control module (PCM) data list. Does the scan tool indicate that the coolant temperature is within the temperature range shown on the temperature gauge?	Go to Engine Overheating	Go to Step 4
4	Replace the instrument panel cluster (IPC). Refer to Instrument Panel Cluster (IPC) Replacement in Instrument Panel, Gauges, and Console. Did you complete the replacement?	Go to Step 5	-
5	Operate the system in order to verify the repair. Did you correct the condition?	System OK	Go to Step 2

ENGINE COOLANT TEMPERATURE INDICATOR ALWAYS ON

Engine Coolant Temperature Indicator Always On

Step	Action	Yes	No
Connector End View Reference: Cooling System Connector End Views DEFINITION: One of the following engine coolant temperature indicators is always On: Engine Coolant, Engine Coolant Hot/Idle Engine, Engine Hot-AC Off, Engine Overheated/Stop Engine.			
1	Did you perform the Engine Cooling Diagnostic System Check?	Go to Step 2	Go To Diagnostic System Check - Engine Cooling
2	Start the engine. Does the Engine Coolant Temperature indicator illuminate?	Go to Step 3	Go to Testing for Intermittent Conditions and Poor Connections in Wiring Systems
3	1. Install a scan tool. 2. With the scan tool, observe the engine coolant temperature parameter in the powertrain control module (PCM) data list.		www.4x4us.net

	Does the scan tool indicate that the coolant temperature is within the temperature range shown on the temperature gauge? www.4x4us.net	Go to Engine Overheating	www.4x4us.net Go to Step 4
4	Replace the instrument panel cluster (IPC). Refer to Instrument Panel Cluster (IPC) Replacement in Instrument Panel, Gauges, and Console. Did you complete the replacement?	Go to Step 5	-
5	Operate the system in order to verify the repair. Did you correct the condition?	System OK	Go to Step 2

LOW ENGINE COOLANT INDICATOR ALWAYS ON

Low Engine Coolant Indicator Always On

Step	Action	Yes	No
Connector End View Reference: Engine Cooling Schematics			
1	Did you perform the Engine Cooling Diagnostic System Check?	Go to Step 2	Go to Diagnostic System Check - Engine Cooling
2	1. Verify that the engine coolant is at the proper level. 2. Turn ON the ignition, with the engine OFF. Does the instrument panel cluster (IPC) display Low Engine Coolant?	Go to Step 3	Go to Testing for Intermittent Conditions and Poor Connections in Wiring Systems
3	1. Install a scan tool. 2. With a scan tool, view the Coolant Level Switch data in the Engine Data 2 data list. Does the scan tool display Low?	Go to Step 4	Go to Step 7
4	1. Disconnect the coolant level sensor electrical connector. 2. Connect a 3-amp fused jumper between the coolant level switch signal circuit of the coolant level sensor electrical connector and the ground circuit of the coolant level sensor electrical connector. 3. With a scan tool, view the Coolant Level Switch data in the Engine Data 2 data list. Does the scan tool display OK?	Go to Step 8	Go to Step 5
5	1. Connect a 3-amp fused jumper between the coolant level switch signal circuit of the coolant level sensor electrical connector and a good ground. 2. With a scan tool, view the Coolant Level Switch data www.4x4us.net		www.4x4us.net

	in the Engine Data 2 data list. www.4x4us.net	Go to Step 10	www.4x4us.net Go to Step 6
6	Does the scan tool display OK? Inspect the coolant level signal circuit for an open or short. Refer to Circuit Testing and Wiring Repairs in Wiring Systems. Did you find and correct the condition?	Go to Step 14	Go to Step 9
7	Inspect for poor connections at the harness connector of the IPC. Refer to Testing for Intermittent Conditions and Poor Connections and Connector Repairs in Wiring Systems. Did you find and correct the condition?	Go to Step 14	Go to Step 11
8	Inspect for poor connections at the harness connector of the coolant level sensor. Refer to Testing for Intermittent Conditions and Poor Connections and Connector Repairs in Wiring Systems. Did you find and correct the condition?	Go to Step 14	Go to Step 12
9	Inspect for poor connections at the harness connector of the powertrain control module (PCM). Refer to Testing for Intermittent Conditions and Poor Connections and Connector Repairs in Wiring Systems. Did you find and correct the condition?	Go to Step 14	Go to Step 13
10	Repair the open in the ground circuit of the coolant level sensor. Refer to Wiring Repairs in Wiring Systems. Did you complete the repair?	Go to Step 14	-
11	Replace the IPC. Refer to Instrument Panel Cluster (IPC) Replacement in Instrument Panel, Gauges and Console. Did you complete the repair?	Go to Step 14	-
12	Replace the surge tank. Refer to Surge Tank Replacement . Did you complete the repair?	Go to Step 14	-
13	Replace the PCM. Refer to Powertrain Control Module (PCM) Replacement in Engine Controls. Did you complete the repair?	Go to Step 14	-
14	Operate the system in order to verify the repair. Did you correct the condition?	System OK	Go to Step 3

ENGINE OVERHEATING

Engine Overheating

Step	Action	Yes	No
1	Inspect for a missing or damaged radiator side or upper baffle and/or radiator air deflector. www.4x4us.net Is the baffle and/or deflector missing or damaged?	www.4x4us.net Go to Step 8	Go to Step 2

2	Inspect for a loss of coolant. Is there a loss of coolant? www.4x4us.net	Go to Step 3	Go to Step 4
3	Fill the system to the specified level. Does the engine overheat?	Go to Step 4	System OK
4	Inspect for low temperature protection. Is the coolant to the correct concentration?	Go to Step 5	Go to Step 8
5	Inspect for a loss of cooling system pressure. Is there a loss of system pressure?	Go to Step 8	Go to Step 6
6	Inspect for a faulty engine coolant temperature (ECT) sensor. Refer to DTC P0117 and DTC P0118 in Engine Controls - 4.8L, 5.3L, and 6.0L. Is the sensor operating properly?	Go to Step 7	Go to Step 8
7	Inspect for the following: <ul style="list-style-type: none"> • Damaged coolant surge tank • Leaking hose • Bad/Incorrect surge tank or radiator cap Were any of the above found?	Go to Step 8	Go to Step 10
8	Repair or install new parts as necessary, then retest. Does the engine overheat?	Go to Step 9	System OK
9	Inspect for incorrect drive belt tension. Is the belt tension correct?	Go to Step 10	Go to Step 8
10	1. Remove the water pump. Refer to Water Pump Replacement . 2. Inspect for a damaged water pump shaft/hub. Is the water pump driveshaft damaged or is the seal leaking?	Go to Step 8	Go to Step 11
11	Inspect for obstructed radiator air flow or bent radiator fins. Is the radiator air flow obstructed?	Go to Step 8	Go to Step 12
12	Inspect for blocked cooling system passages. Are the cooling system passages blocked?	Go to Step 8	Go to Step 13
13	Inspect for inoperative fan clutch. Refer to Fan Clutch Diagnosis . Is the fan clutch operating correctly?	Go to Step 14	Go to Step 8
14	Inspect the thermostat. Refer to Thermostat Diagnosis . Is the thermostat stuck in the closed position?	Go to Step 15	Go to Step 16
15	Replace the thermostat. Refer to Thermostat Housing Replacement . Does the engine overheat?	Go to Step 16	System OK
16	Inspect the radiator cooling capacity. Is the proper sized radiator being used on the vehicle?	Go to Step 3	Go to Step 17
17	Consult the current parts catalog and replace the radiator. Refer to Radiator Replacement . www.4x4us.net	System OK	www.4x4us.net

Loss of Coolant

Step	Action	Yes	No
DEFINITION: The cooling system is losing coolant either internally or externally.			
1	Were you sent here from Symptoms, or another diagnostic table?	Go to Step 2	Go to Symptoms - Engine Cooling
2	Repair any present DTCs. Refer to Diagnostic System Check - Engine Cooling . Is the action complete?	Go to Step 3	-
3	Inspect the coolant level. Is the coolant at the proper level?	Go to Step 5	Go to Step 4
4	Fill the cooling system to the proper level. Refer to Draining and Filling Cooling System . Is the action complete?	Go to Step 5	-
5	Engine overheating can cause a loss of coolant. Is the engine overheating?	Go to Step 19	Go to Step 6
6	1. Idle the engine at normal operating temperature. 2. Inspect for heavy white smoke coming out of the exhaust pipe. Is a heavy white smoke present from the exhaust pipe?	Go to Step 7	Go to Step 8
7	Coolant in the exhaust system creates a distinctive, burning coolant odor in the exhaust. Condensation in the exhaust system can cause an odorless white smoke during engine warm up. Does the white smoke have a burning coolant type odor?	Go to Step 20	Go to Step 8
8	Visually inspect the hoses, pipes and hose clamps. Are any of the hoses, clamps or pipes leaking?	Go to Step 21	Go to Step 9
9	Visually inspect the following components: <ul style="list-style-type: none"> • Block heater • Coolant pressure cap • Core plugs • Throttle Body • Engine block • Intake manifold • Radiator • Thermostat housing • Water pump www.4x4us.net	Go to Step 21	Go to Step 10

10	<p>1. Pressure test the cooling system. Refer to Cooling System Leak Testing .</p> <p>2. With the cooling system pressurized, visually inspect the components listed in steps 7 and 8.</p> <p>Are any leaks present?</p>	Go to Step 21	Go to Step 11
11	<p>Pressure test the coolant pressure cap. Refer to Pressure Cap Testing .</p> <p>Does the coolant pressure cap hold pressure?</p>	Go to Step 12	Go to Step 16
12	<p>Inspect for the following conditions:</p> <ul style="list-style-type: none"> • A coolant smell inside of the vehicle • Coolant in the HVAC module drain tube • Coolant on the vehicle floor covering near the HVAC module <p>Is coolant present?</p>	Go to Step 21	Go to Step 13
13	<p>Inspect the underside of the engine oil fill cap for a gray/white milky substance.</p> <p>Is there a milky substance under the oil fill cap?</p>	Go to Step 14	Go to Step 15
14	<p>Inspect the engine oil fluid level indicator for a gray/white milky substance.</p> <p>Is there a milky substance on the engine oil fluid level indicator?</p>	Go to Step 17	Go to Step 15
15	<p>Inspect the automatic transmission oil fluid level indicator, if equipped, for a gray/white milky substance.</p> <p>Is there a milky substance on the automatic transmission fluid level indicator?</p>	Go to Step 18	Go to Step 22
16	<p>Replace the coolant pressure cap.</p> <p>Is the repair complete?</p>	Go to Step 22	-
17	<p>1. Replace the radiator. Refer to Radiator Replacement .</p> <p>2. Service the engine oil and filter. Refer to Engine Oil and Oil Filter Replacement in Engine Mechanical - 4.8L, 5.3L, and 6.0L.</p> <p>Is the repair complete?</p>	Go to Step 22	-
18	<p>1. Replace the radiator. Refer to Radiator Replacement .</p> <p>2. Service the automatic transmission. Refer to Engine Coolant/Water in Transmission in Automatic Transmission.</p> <p>Is the repair complete?</p>	Go to Step 22	-
	<p>Repair the engine overheating condition. Refer to Engine</p>		

19	Overheating . www.4x4us.net Is the repair complete?	Go to Step 22	www.4x4us.net
20	Repair the engine internal coolant leak. Refer to Coolant in Combustion Chamber and Coolant in Engine Oil in Engine Mechanical - 6.0L. Is the repair complete?	Go to Step 22	-
21	Repair or replace the leaking component. Refer to the appropriate repair. Is the repair complete?	Go to Step 22	-
22	Operate the system in order to verify the repair. Did you find and correct the condition?	System OK	Go to Step 2

THERMOSTAT DIAGNOSIS

Tools Required

J 24731 Tempil Stick. See **Special Tools and Equipment** .

Use one of the following procedures in testing for a malfunctioning thermostat.

Thermostat Test Procedure Using Tempil Sticks

The coolant thermostat can be tested using a temperature (tempil) stick. The temperature stick is a pencil like device. It has a wax material containing certain chemicals which melt at a given temperature. Temperature sticks can be used to determine a thermostat's operating range, by rubbing 87° C (188° F) and 97° C (206° F) sticks on the thermostat housing.

- Use a tempil stick in order to find the opening and the closing temperatures of the coolant thermostat.
 - J 24731** -188 tempil stick melts at 87° C (188° F). The thermostat should begin to open. See **Special Tools and Equipment** .
 - J 24731** -206 tempil stick melts at 97° C (206° F). The thermostat should be fully open. See **Special Tools and Equipment** .
- Replace the coolant thermostat if it does not operate properly between this temperature range.

Thermostat Test Procedure Using Glycol

Inspect the operation of the thermostat by hanging the thermostat on a hook in a 50/50 percent solution of DEX-COOL(R) and clean drinkable water.

In order to inspect if the thermostat valve is opening properly, perform the following test:

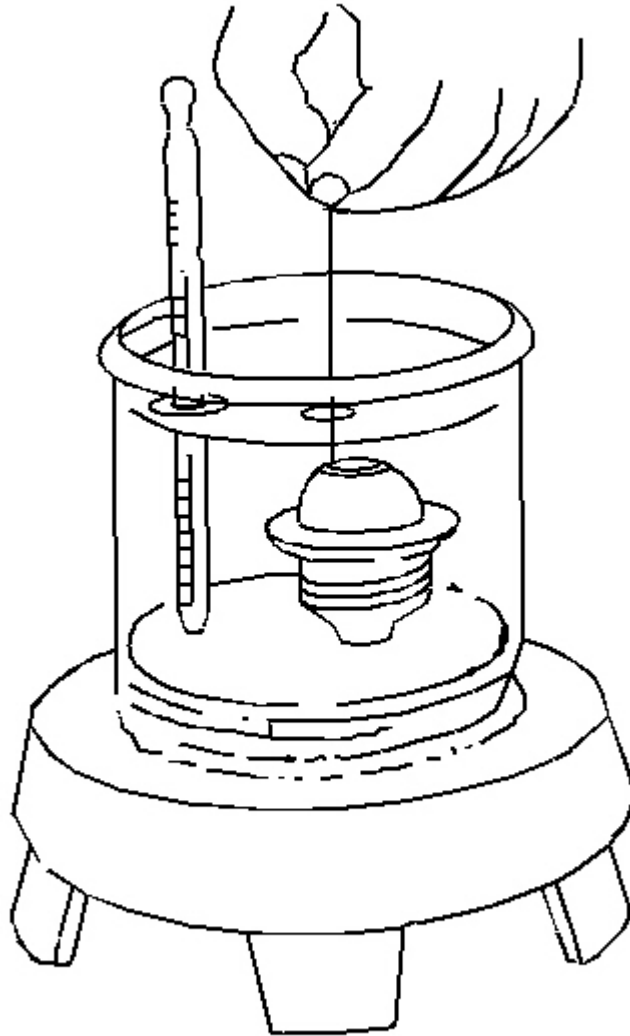

Fig. 3: Thermostat Test Procedure Using Glycol
Courtesy of GENERAL MOTORS CORP.

1. Completely submerge the thermostat in the glycol solution. The solution should be 11°C (22°F) above the temperature indicated on the thermostat valve.
2. Thoroughly agitate the solution. Under these conditions, the thermostat valve should open.

In order to verify that the thermostat valve is closing properly, perform the following test.

1. Completely submerge the thermostat in a glycol solution. The solution should be 6° C (10° F) below the temperature indicated on the thermostat valve.
2. Thoroughly agitate the solution. Under these conditions, the thermostat valve should close completely.

COOLANT HEATER INOPERATIVE

Coolant Heater Inoperative

Step	Action	Yes	No
Connector End View Reference: Cooling System Connector End Views			
1	Did you perform the necessary inspections?	Go to Step 2	Go to Symptoms - Engine Cooling
2	Test the engine coolant heater power supply cord for an open or short to ground. Refer to Circuit Testing in Wiring Systems. Did you find a condition?	Go to Step 3	Go to Step 4
3	Replace the engine coolant heater power supply cord. Refer to Coolant Heater Cord Replacement . Did you complete the repair?	Go to Step 6	-
4	Inspect for poor connections at the harness connector of the engine coolant heater. Refer to Testing for Intermittent Conditions and Poor Connections and Connector Repairs in Wiring Systems. Did you find and correct the condition?	Go to Step 6	Go to Step 5
5	Replace the engine coolant heater. Refer to Coolant Heater Replacement . Did you complete the repair?	Go to Step 6	-
6	Operate the system in order to verify the repair. Did you correct the condition?	System OK	Go to Step 2

ENGINE FAILS TO REACH NORMAL OPERATING TEMPERATURE

Engine Fails To Reach Normal Operating Temperature

Step	Action	Yes	No
1	Did you review the Symptoms-Engine Cooling diagnostic information and perform the necessary inspections?	Go to Step 2	Go to Symptoms - Engine Cooling
2	Verify that the engine does not reach normal operating temperature. Does the engine reach normal operating temperature?	System OK	Go to Step 3
3	Inspect the coolant level. Is the coolant level below the add mark?	Go to Step 4	Go to Step 5
4	1. Add coolant as necessary. 2. Perform a cooling system pressure test. Does the cooling system hold pressure?	System OK	Go to Step 5
	Inspect for a stuck open, missing, or incorrect thermostat. Refer		

5	to Thermostat Diagnosis . www.4x4us.net Is the thermostat operating properly?	System OK	www.4x4us.net Go to Step 6
6	Install the correct replacement thermostat. Refer to Thermostat Housing Replacement Is the repair complete?	Go to Step 7	-
7	Run the engine in order to verify the repair. Does the engine fail to reach normal operating temperature?	-	System OK

PRESSURE CAP TESTING

Tools required

- **J 24460-01** Cooling System Pressure Tester. See **Special Tools and Equipment** .
- **J 42401** Radiator Cap/Surge Tank Test Adapter. See **Special Tools and Equipment** .

Pressure Cap Testing

CAUTION: To avoid being burned, do not remove the radiator cap or surge tank cap while the engine is hot. The cooling system will release scalding fluid and steam under pressure if radiator cap or surge tank cap is removed while the engine and radiator are still hot.

1. Remove the pressure cap.
2. Wash the pressure cap sealing surface with water.

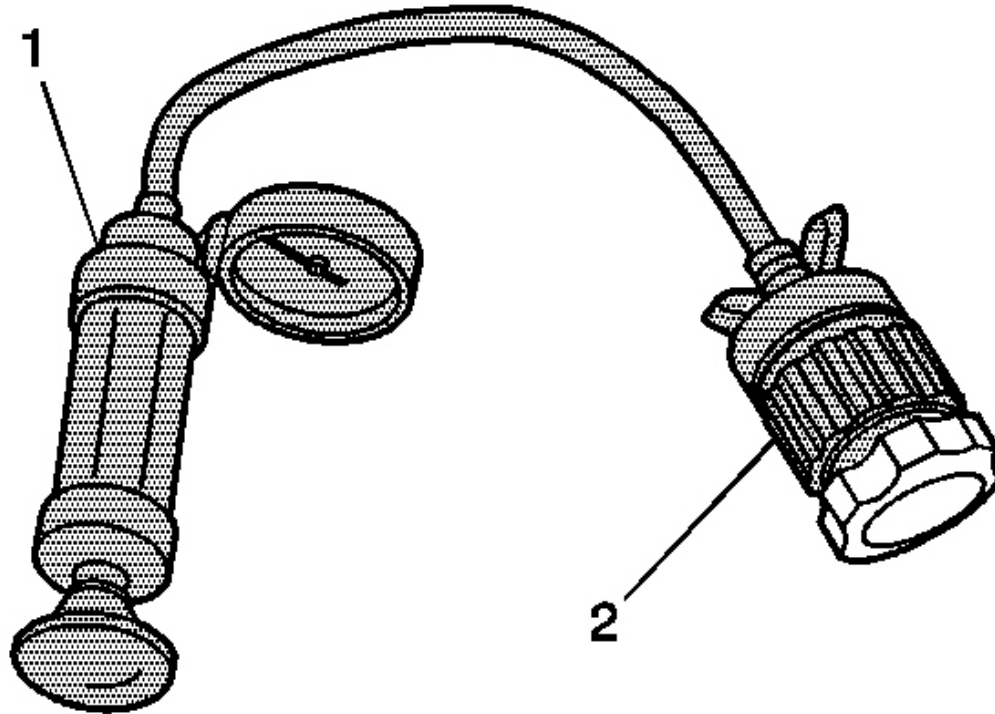

Fig. 4: J 24460-01 & J 42401
Courtesy of GENERAL MOTORS CORP.

3. Use the **J 24460-01** (1) with **J 42401** (2) in order to test the pressure cap. See **Special Tools and Equipment** .
4. Test the pressure cap for the following conditions:
 - Pressure release when the **J 24460-01** exceeds the pressure rating of the pressure cap. See **Special Tools and Equipment** .
 - Maintain the rated pressure for at least 10 seconds.Note the rate of pressure loss.
5. Replace the pressure cap under the following conditions:
 - The pressure cap does not release pressure which exceeds the rated pressure of the cap.
 - The pressure cap does not hold the rated pressure.

Tools Required

www.4x4us.net

www.4x4us.net

- **J 24460-01** Cooling System Pressure Tester. See Special Tools and Equipment .
- **J 42401** Radiator Cap/Surge Tank Test Adapter. See Special Tools and Equipment .

CAUTION: Under pressure, the temperature of the solution in the radiator can be considerably higher, without boiling. Removing the radiator cap while the engine is hot (pressure is high), will cause the solution to boil instantaneously, with explosive force. The solution will spew out over the engine, fenders, and the person removing the cap. Serious bodily injury may result. Flammable antifreeze, such as alcohol, is not recommended for use at any time. Flammable antifreeze could cause a serious fire.

CAUTION: In order to help avoid being burned, do not remove the radiator cap while the engine and the radiator are hot. Scalding fluid and steam can be blown out under pressure if the cap is removed too soon.

1. Remove the pressure cap.
2. Test the operation of the pressure cap. Refer to Pressure Cap Testing .
3. Wash the pressure cap mating surface with water.

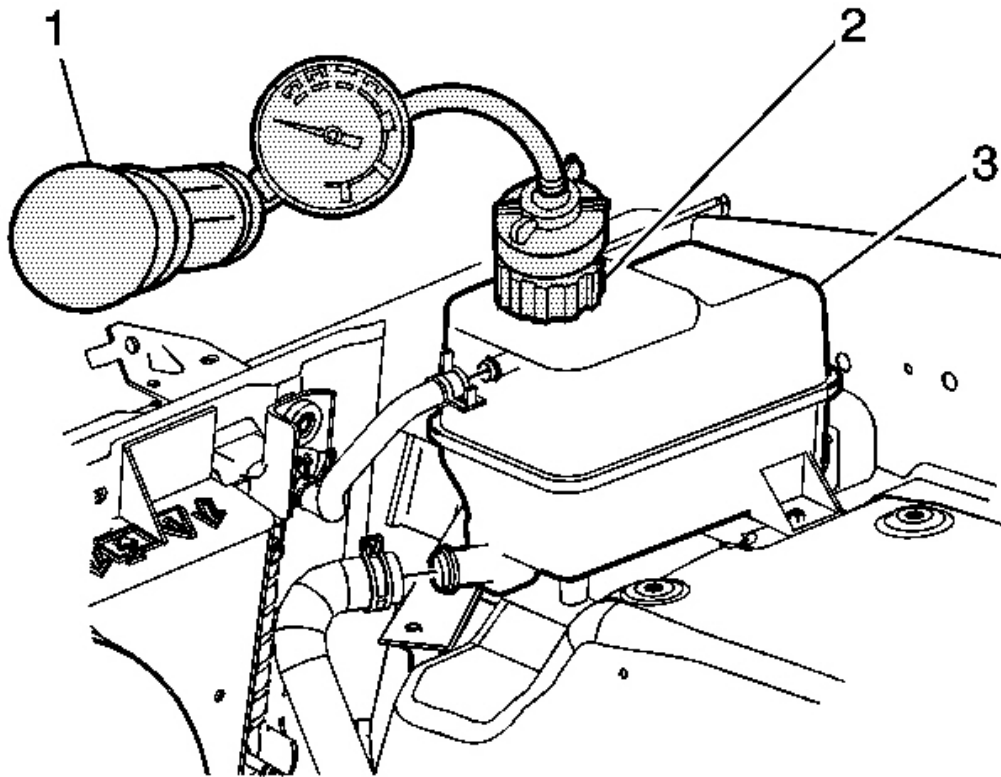

Fig. 5: Using J 24460-01 With J42401 To Apply Pressure To Cooling System
 Courtesy of GENERAL MOTORS CORP.

4. Use the **J 24460-01** with the **J 42401** in order to apply pressure to the cooling system. See **Special Tools and Equipment** .

Do not exceed the pressure cap rating.

5. The cooling system should hold the rated pressure for at least 2 minutes.

Observe the gauge for any pressure loss.

6. Repair any leaks as required.

FAN CLUTCH DIAGNOSIS

Step	Action	Yes	No
------	--------	-----	----

Definition: Testing the engagement and disengagement of the fan clutch.

1	Were you sent here from Symptoms or another diagnostic table?	Go to Step 2	Go to Symptoms - Engine Cooling
2	Do you notice excessive fan air noise?	Go to Step 3	Go to Step 4
3	Fan air noise is normal during cold engine start up. Does the fan noise go away at normal engine operating temperature?	Go to Step 13	Go to Step 4
4	IMPORTANT: The engine must be turned OFF and the engine temperature should be cold. Rotate the fan clutch.Does the fan clutch rotate?	Go to Step 5	Go to Step 14
5	Visually inspect the fan blades for cracks, looseness or damage. Are the fan blades in good condition?	Go to Step 6	Go to Step 15
6	Visually inspect the fan clutch for signs of silicone leakage. <ul style="list-style-type: none"> • Slight silicone leakage may not effect the fan clutch engagement. • Excess leakage will prevent the fan clutch from engaging. Is the silicone fluid leakage excessive?	Go to Step 14	Go to Step 7
7	Inspect the fan clutch for proper installation. <ol style="list-style-type: none"> 1. Move the fan blade back and forth in a lateral motion. 2. Inspect for fan blade to fan clutch movement. Is the fan blade loose at the fan clutch?	Go to Step 10	Go to Step 8
8	Inspect the fan clutch for wear. <ol style="list-style-type: none"> 1. Move the fan blade back and forth in a lateral motion. IMPORTANT: Approximately 6.5 mm (1/4 in) movement at the tip of the fan blade is normal. <ol style="list-style-type: none"> 2. Inspect for fan clutch lateral movement. Is the fan clutch lateral movement excessive?	Go to Step 14	Go to Step 9
9	The fan clutch should have more turning resistance when the engine is at or above normal operating temperature.		

	Does the fan clutch have more resistance when the engine temperature is raised? www.4x4us.net	Go to Step 11	www.4x4us.net Go to Step 14
10	Tighten the fan. Refer to Fastener Tightening Specifications . Is the repair complete?	Go to Step 16	-
11	Perform a fan clutch engagement test. <ol style="list-style-type: none"> 1. Ensure the engine coolant level is full. 2. Ensure the cooling fan drive belt tension is correct and not slipping. 3. Position and secure a thermometer between the fan clutch and the radiator. 4. Ensure the cooling fan is disengaged before starting this test. 5. Sufficiently cover the radiator grille to restrict the air flow. <p>IMPORTANT: Do not allow engine temperature to exceed 121° C (250° F).</p> <ol style="list-style-type: none"> 6. Start the engine. 7. Turn the A/C ON. 8. Operate the engine at approximately 2,000 RPM. 9. Inspect the thermometer reading when the fan clutch engages. 10. Do not continue this test if the fan clutch does not engage between 85-96° C (185-205° F). <p>Fan clutch engagement will be indicated by an increase in fan air noise, fan speed, and a drop of about 3-10° C (5-15° F) on the thermometer reading. Did the fan clutch engage between 85-96° C (185-205° F)?</p>	Go to Step 12	Go to Step 14
12	Once the fan clutch engages, perform the following steps: <ol style="list-style-type: none"> 1. Uncover the radiator grille. 2. Turn the A/C OFF. 3. Operate the engine at approximately 2,500 RPM to reduce the engine operating temperature. 4. Remove the thermometer. <p>Did the engine return to normal operating temperature?</p>	Go to Step 13	-
13	As the engine temperature returns to normal, the fan clutch will disengage, indicated by a reduction in fan air noise and fan speed. www.4x4us.net Did the fan clutch disengage?	Go to Step 16	www.4x4us.net Go to Step 14
	Replace the fan clutch. Refer to Fan Clutch Replacement .	Go to	

14	Is the repair complete? www.4x4us.net	Step 16	-
15	Replace the fan blades. Refer to Fan Replacement . Is the repair complete?	Go to Step 16	www.4x4us.net -
16	Operate the fan clutch to verify proper operation. Did you find and correct the condition?	System OK	Go to Step 2

REPAIR INSTRUCTIONS

DRAINING AND FILLING COOLING SYSTEM

Tools Required

- **J 26568** Coolant and Battery Tester. See **Special Tools and Equipment** .
- **J 38185** Hose Clamp Pliers. See **Special Tools and Equipment** .

Draining Procedure

CAUTION: To avoid being burned, do not remove the radiator cap or surge tank cap while the engine is hot. The cooling system will release scalding fluid and steam under pressure if radiator cap or surge tank cap is removed while the engine and radiator are still hot.

1. Follow the steps below in order to remove the surge tank fill cap.
 1. Slowly rotate the cap counterclockwise.
 2. Stop rotating and allow the hissing to stop.
 3. After all the hissing stops, continue turning counterclockwise in order to remove the cap.
2. Raise and support the vehicle. Refer to **Lifting and Jacking the Vehicle** in General Information.
3. Place a drain pan under the lower radiator hose.
4. Using the **J 38185** , reposition the lower radiator hose clamp. See **Special Tools and Equipment** .
5. Remove the lower radiator hose from the radiator.
6. Drain the cooling system.

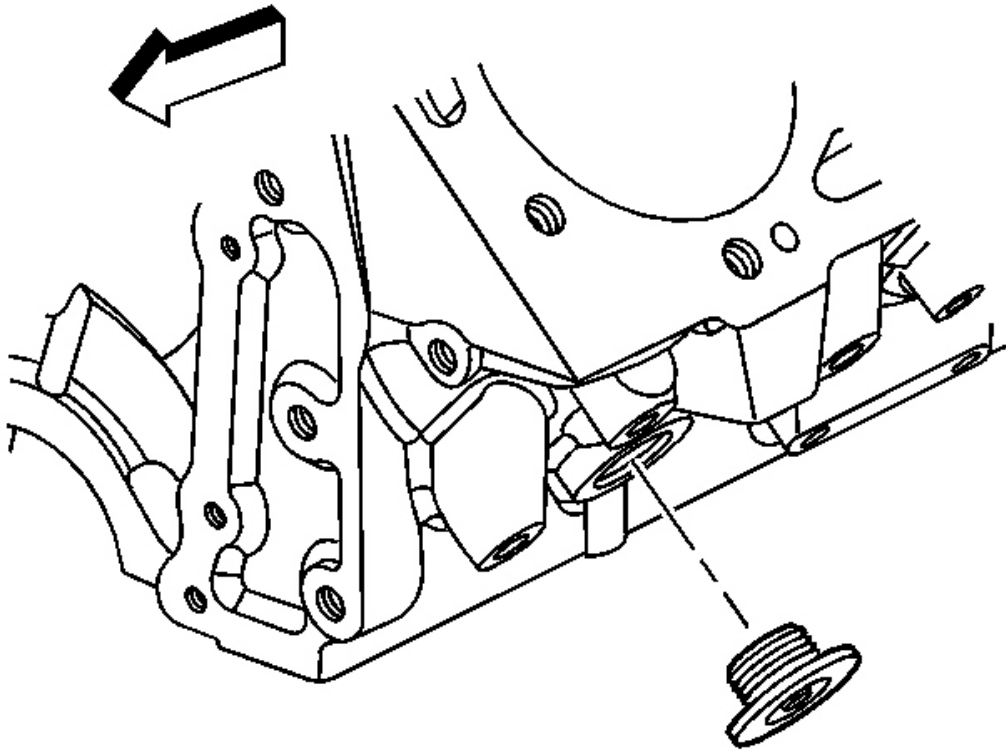

Fig. 6: Left & Right Engine Block Coolant Drain Hole Plugs
Courtesy of GENERAL MOTORS CORP.

7. If a complete engine block drain is required, remove the left and right engine block coolant drain plugs.
8. Remove the engine block coolant heater, if equipped. Refer to **Coolant Heater Replacement** .
9. Inspect the coolant.
10. Follow the appropriate procedure based on the condition of the coolant.
 - Normal in appearance-Follow the filling procedure.
 - Discolored-Follow the flush procedure. Refer to **Flushing** .

Filling Procedure

NOTE: The procedure below must be followed. Improper coolant level could result in a low or high coolant level condition, causing engine damage.

1. Insert the **J 38185** or hose to the radiator. www.4x4us.net
2. Using the **J 38185** reposition the lower radiator hose clamp. See **Special Tools and Equipment** .

3. If the left and right engine block coolant drain plugs were removed, perform the following.
1. Apply pipe sealer to the drain plugs.

NOTE: Refer to Fastener Notice in **Cautions and Notices**.

2. Install the drain plugs.

Tighten: Tighten the drain plugs to 60 N.m (44 lb ft).

4. Install the engine block coolant heater, if equipped. Refer to Coolant Heater Replacement .
5. Lower the vehicle.
6. Open the cooling system bleeder screws.

IMPORTANT: Use a 50/50 mixture of DEX-COOL antifreeze and clean, drinkable water.

7. Slowly fill the cooling system with a 50/50 coolant mixture. Refer to Capacities - Approximate Fluid in Maintenance and Lubrication.
8. Close the cooling system bleeder screws.
9. Install the coolant pressure cap.
10. Start the engine.
11. Run the engine at 2,000-2,500 RPM until the engine reaches normal operating temperature.
12. Allow the engine to idle for 3 minutes.
13. Shut the engine OFF.
14. Allow the engine to cool.
15. Top off the coolant as necessary.
16. Inspect the concentration of the engine coolant using the **J 26568** . See Special Tools and Equipment .
17. Rinse away any excess coolant from the engine and the engine compartment.

FLUSHING

IMPORTANT:

- Do not use a chemical flush.
- Store used coolant in the proper manner, such as in a used engine coolant holding tank. Do not pour used coolant down a drain. Ethylene glycol antifreeze is a very toxic chemical. Do not dispose of coolant into the sewer system or ground water. This is illegal and ecologically unsound.
- Various methods and equipment can be used to flush the cooling system. If special equipment is used (such as a back flusher) follow the manufacturer's instructions. However, always remove the thermostat before back flushing the system.

1. Block the drive wheels.
2. Place the transmission in park (P) or neutral (N).
3. Engage the park brake.
4. Run the engine until the thermostat opens.
5. Stop the engine.
6. Follow the drain and fill procedure using only clean drinkable water. Repeat the procedure if necessary, until the fluid is nearly colorless. Refer to Draining and Filling Cooling System .
7. Fill the coolant reservoir to the FULL HOT mark.
8. Fill the cooling system. Refer to Draining and Filling Cooling System .

RADIATOR CLEANING

CAUTION: NEVER spray water on a hot radiator. The resulting steam could cause personal injury.

NOTE: The radiator fins are necessary for good heat transfer. Do not brush the fins. This may cause damage to the fins, reducing heat transfer.

IMPORTANT: Remove bugs, leaves, dirt and other debris by blowing compressed air through the engine side of the radiator.

- Some conditions may require the use of warm water and a mild detergent.
- Clean the A/C condenser fins.
- Clean between the A/C condenser and radiator.
- Clean the radiator cooling fins.
- Straighten any damaged cooling fins.

SURGE TANK REPLACEMENT

Removal Procedure

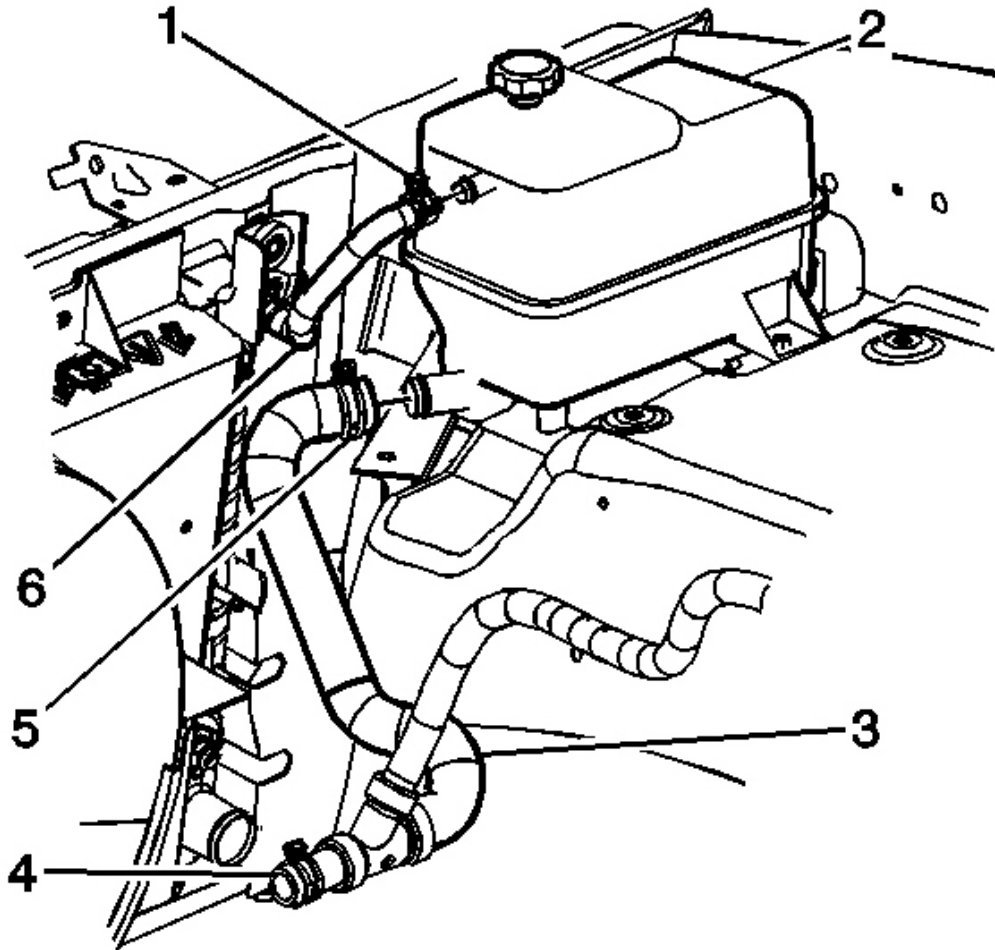

Fig. 7: Surge Tank Components
Courtesy of GENERAL MOTORS CORP.

1. Drain the cooling system. Refer to **Draining and Filling Cooling System** .
2. Reposition the surge tank inlet hose clamp (1) from the surge tank (2).
3. Remove the surge tank inlet hose (6) from the surge tank (2).
4. Reposition the surge tank outlet hose clamp (5) from the surge tank (2).
5. Remove the surge tank outlet hose (3) from the surge tank (2).

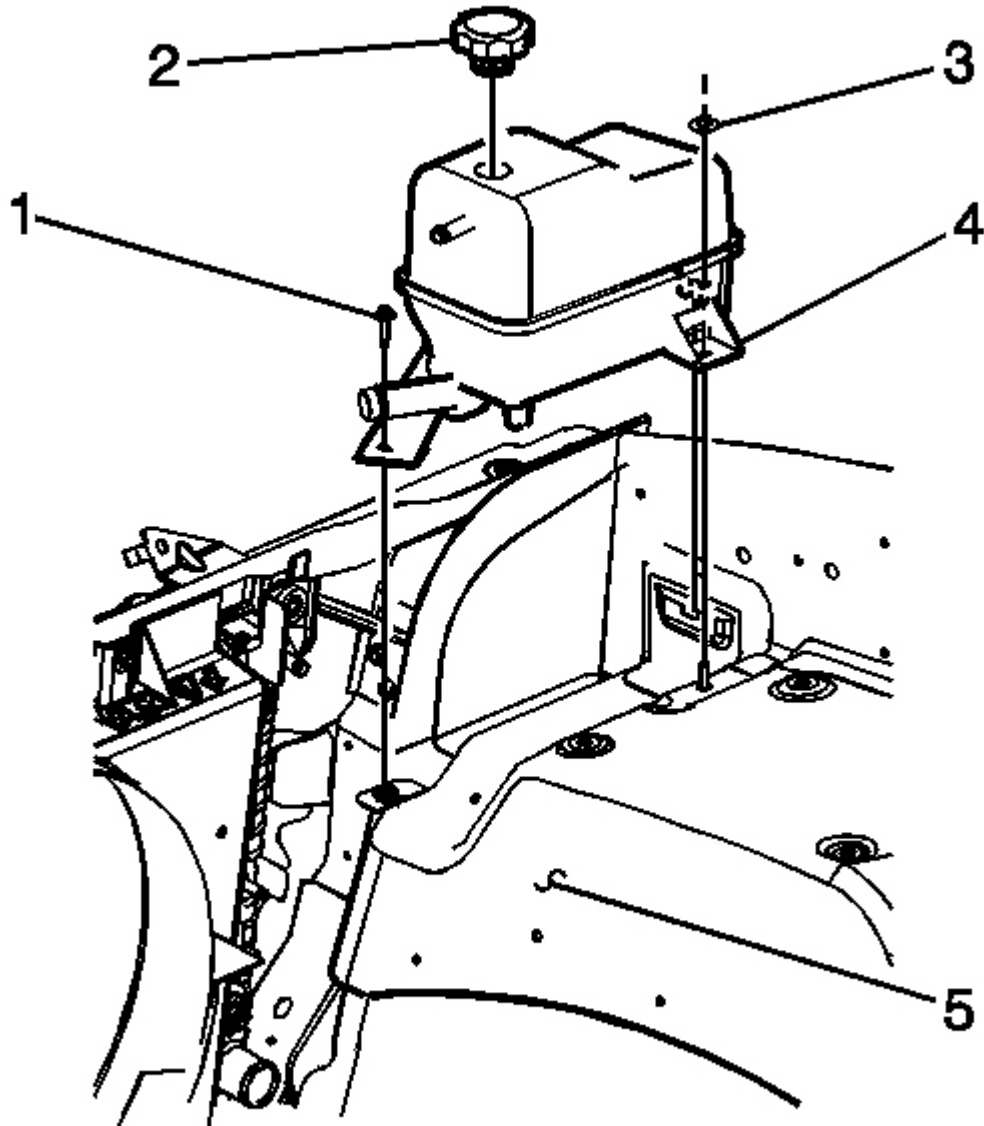

Fig. 8: Identifying Surge Tank
Courtesy of GENERAL MOTORS CORP.

6. Remove the bolt (1) from the surge tank (4).
7. Remove the nut (2) from the surge tank (4).
8. If equipped disconnect the electrical connector from the low coolant level switch.

9. Remove the surge tank (4) from the vehicle (5).

www.4x4us.net

www.4x4us.net

Installation Procedure

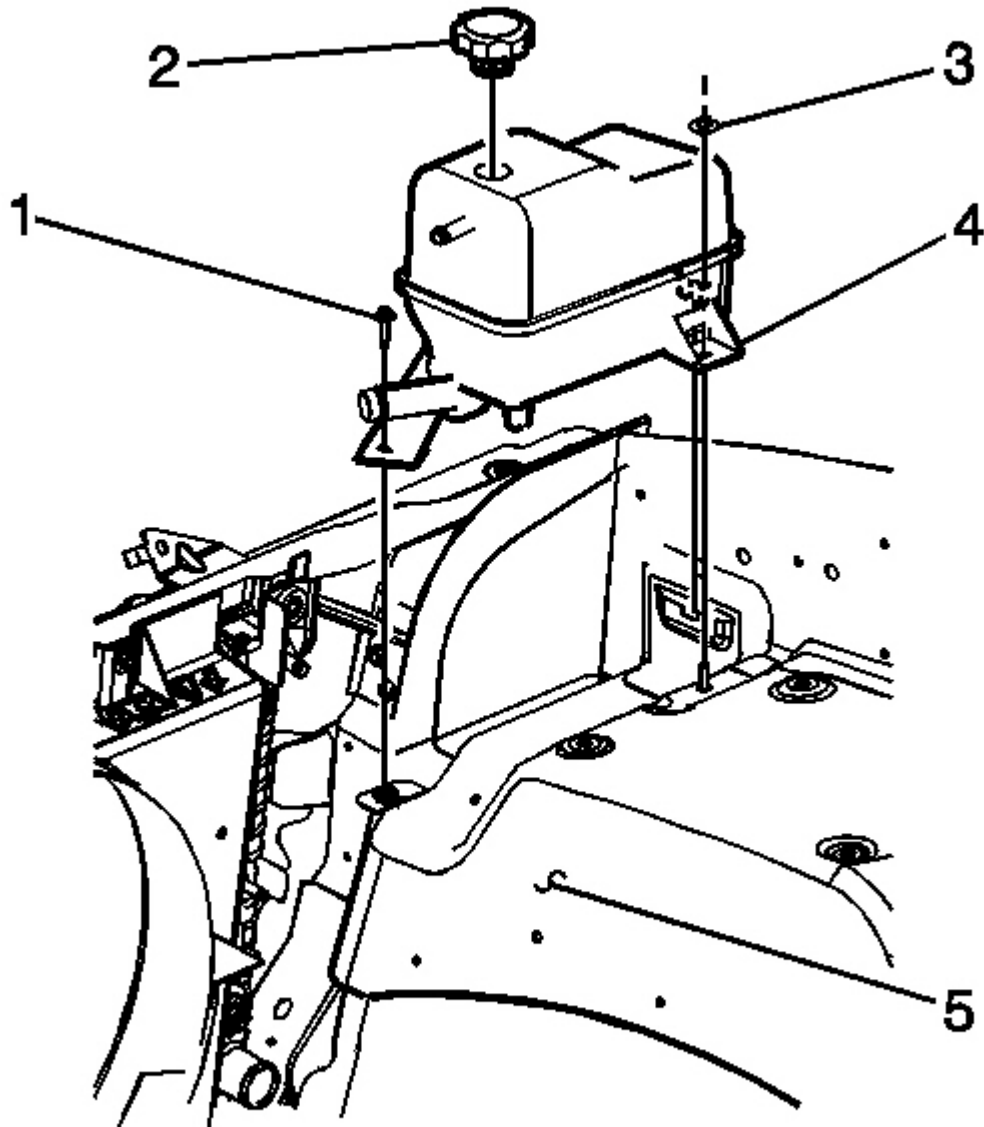

Fig. 9: Identifying Surge Tank
www.4x4us.net
Courtesy of GENERAL MOTORS CORP.

www.4x4us.net

1. Install the surge tank (4) to the vehicle (5).

www.4x4us.net

www.4x4us.net

2. If equipped connect the electrical connector to the low coolant level switch.

NOTE: Refer to Fastener Notice in Cautions and Notices.

3. Install the bolt (1) to the surge tank (4).

Tighten: Tighten the bolt to 9 N.m (80 lb in).

4. Install the nut (3) to the surge tank (4).

Tighten: Tighten the nut to 9 N.m (80 lb in).

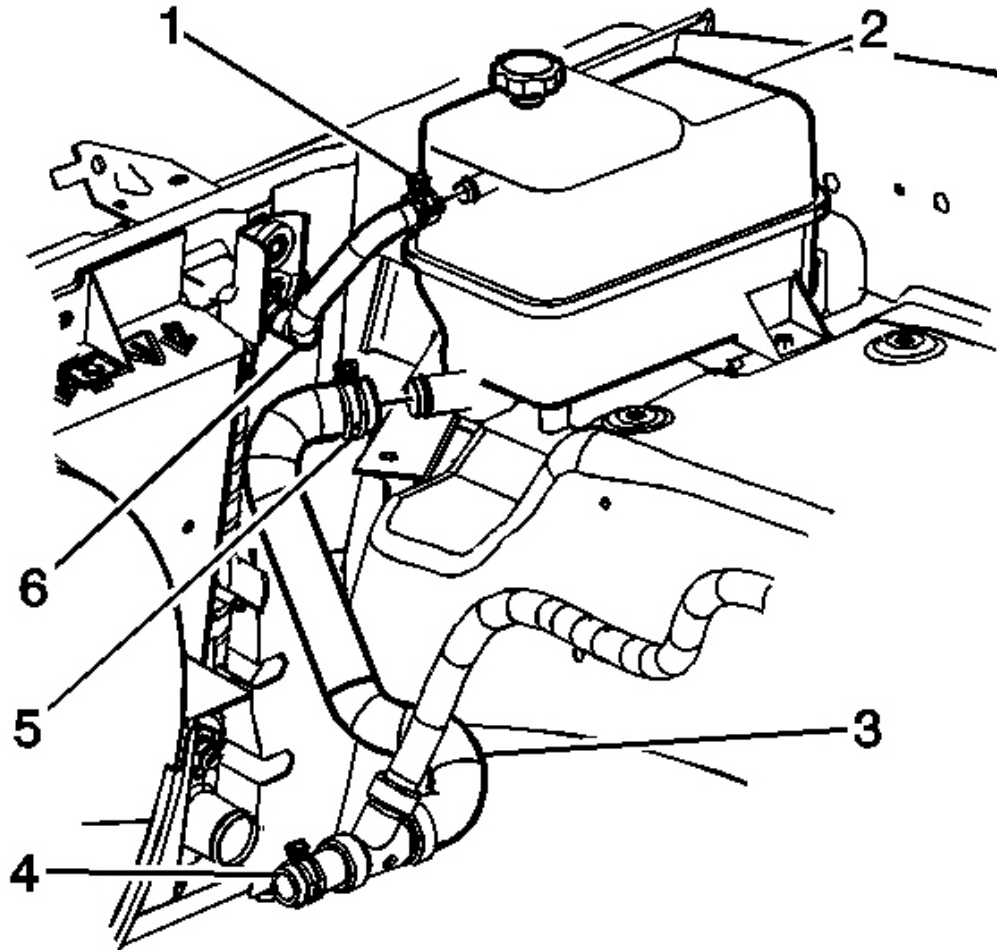

Fig. 10: Surge Tank Components
Courtesy of GENERAL MOTORS CORP.

5. Install the surge tank outlet hose (3) to the surge tank (2).
6. Position the surge tank outlet hose clamp (5) to the surge tank (2).
7. Install the surge tank inlet hose (6) to the surge tank (2).
8. Position the surge tank inlet hose clamp (1) to the surge tank (2).
9. Fill the cooling system. Refer to **Draining and Filling Cooling System** .

SURGE TANK HOSE/PIPE REPLACEMENT - INLET

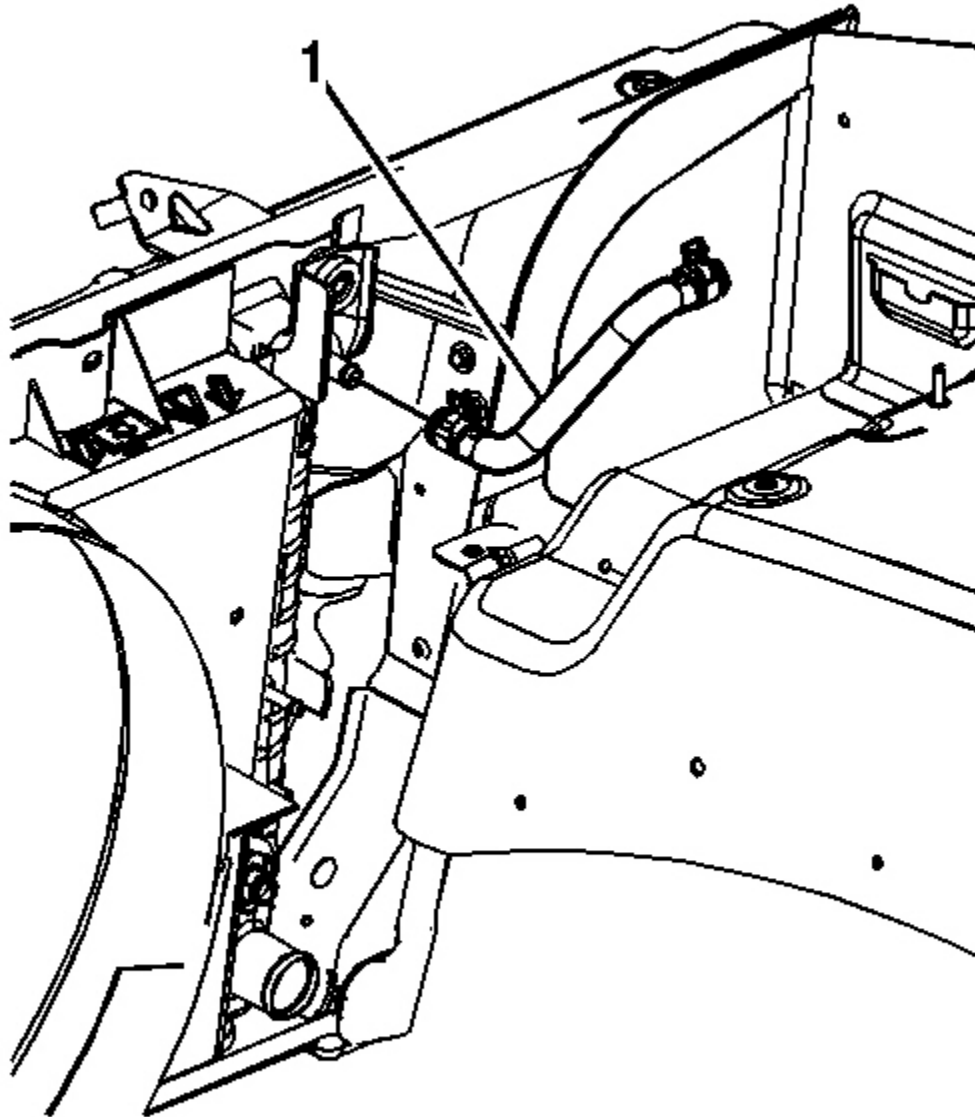

Fig. 11: Surge Tank Hose & Radiator
Courtesy of GENERAL MOTORS CORP.

1. Drain the cooling system. Refer to [Draining and Filling Cooling System](#) .
2. Reposition the surge tank inlet hose clamp from the radiator.
3. Remove the surge tank inlet hose (1) from the radiator.

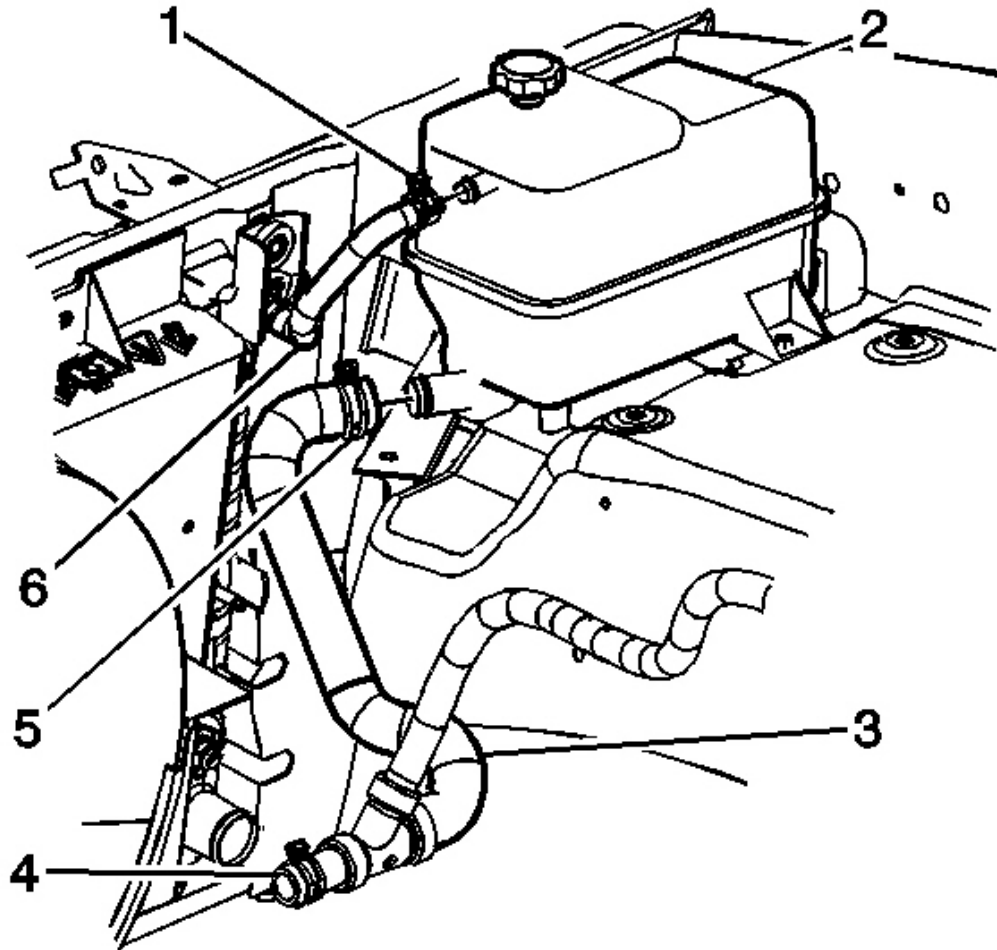

Fig. 12: Surge Tank Components
Courtesy of GENERAL MOTORS CORP.

4. Reposition the surge tank inlet hose clamp (1) at the surge tank (2).
5. Remove the surge tank inlet hose (6) from the surge tank (2).

Installation Procedure

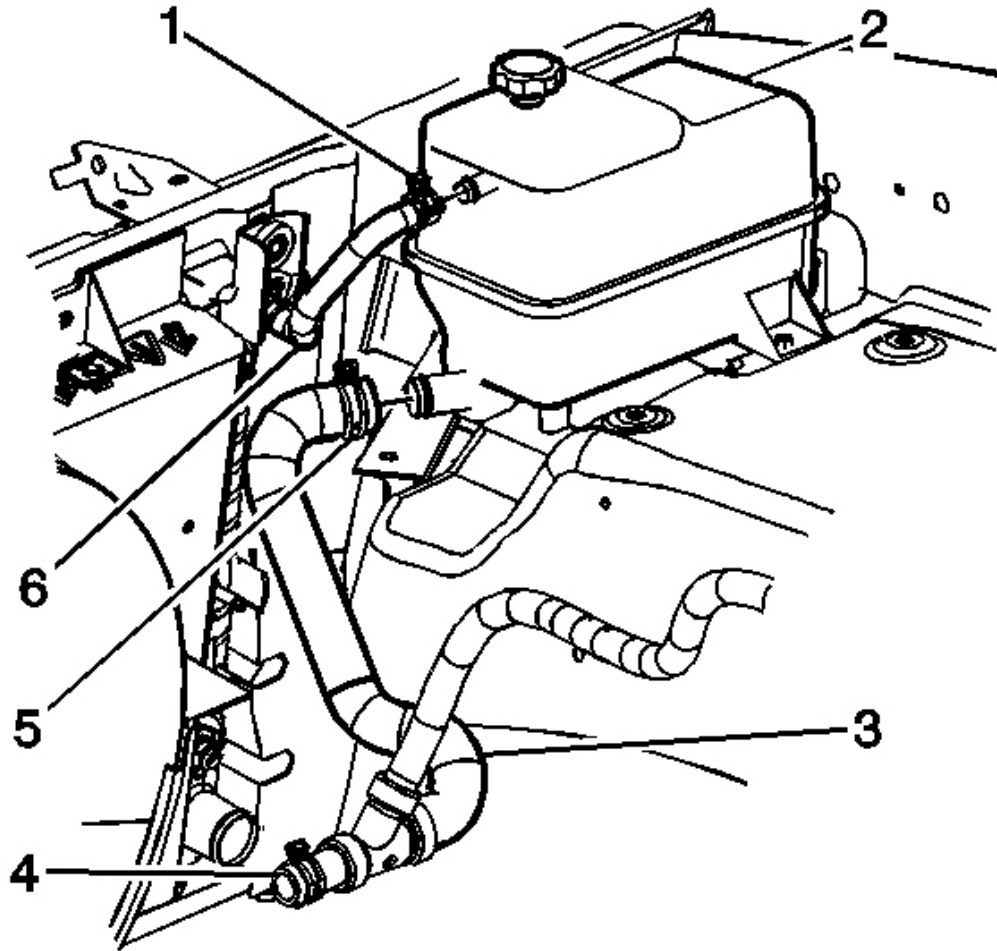

Fig. 13: Surge Tank Components
Courtesy of GENERAL MOTORS CORP.

1. Install the surge tank inlet hose (6) to the surge tank (2).
2. Position the surge tank inlet hose clamp (1) to the surge tank (2).

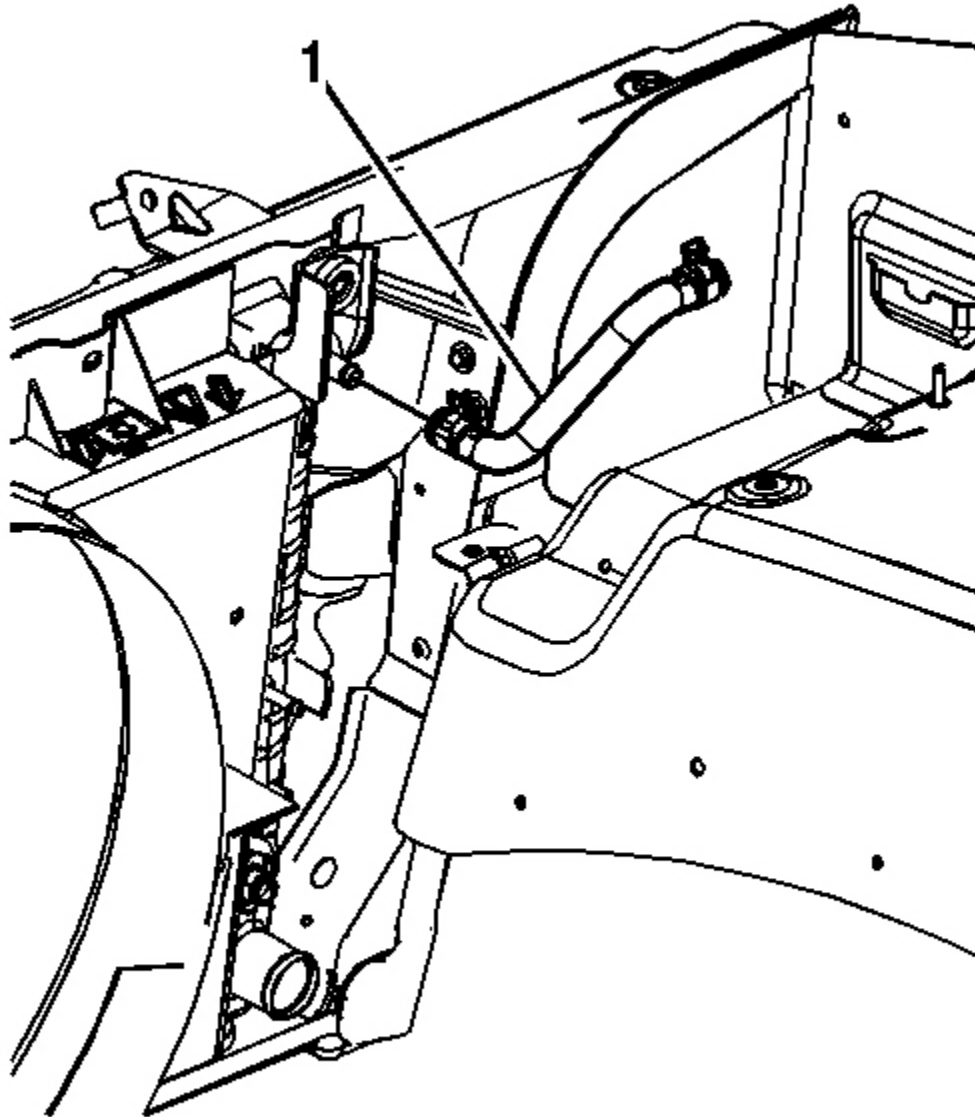

Fig. 14: Surge Tank Hose & Radiator (Inlet)
Courtesy of GENERAL MOTORS CORP.

3. Install the surge tank inlet hose (1) to the radiator.
4. Position the surge tank inlet hose clamp to the radiator.
5. Fill the cooling system. Refer to [Draining and Filling Cooling System](#) .

SURGE TANK HOSE/PIPE REPLACEMENT - OUTLET

www.4x4us.net

www.4x4us.net

Tools Required

J 43181 Heater Line Quick Connect Release Tool. See Special Tools and Equipment .

Removal Procedure

1. Drain the cooling system. Refer to Draining and Filling Cooling System .
2. Remove the air cleaner resonator outlet duct. Refer to Air Cleaner Resonator Outlet Duct Replacement in Engine Controls - 4.8L, 5.3L and 6.0L.

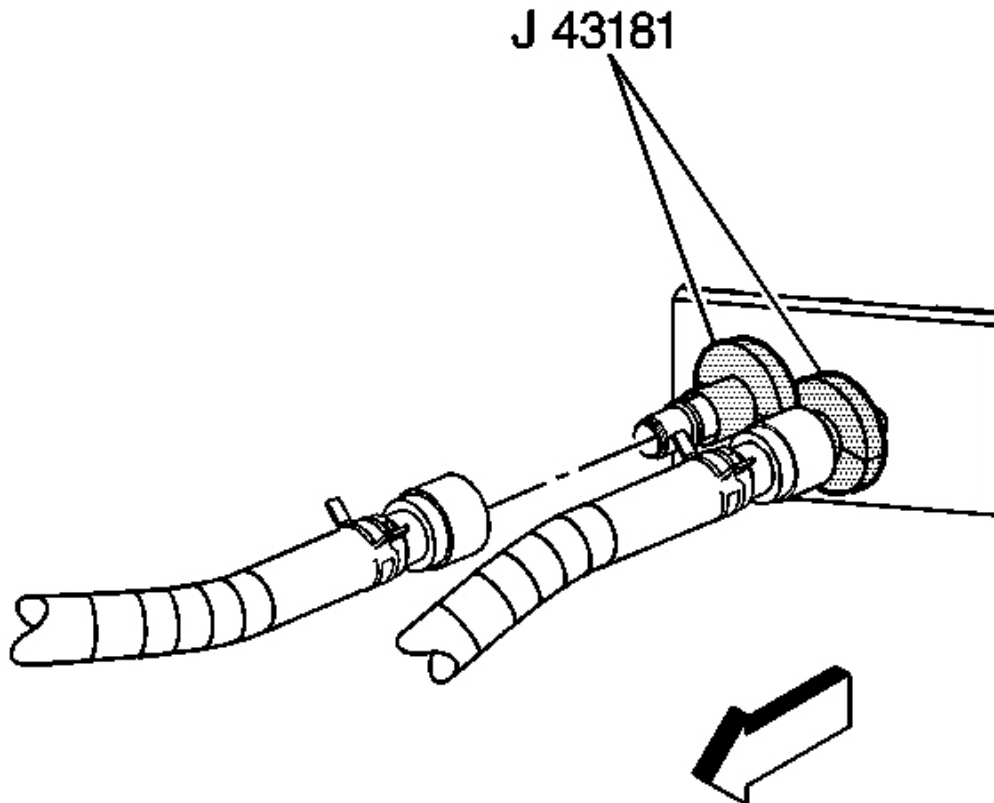

Fig. 15: Identifying Heater Hose To Heater Core Outlet
Courtesy of GENERAL MOTORS CORP.

3. www.4x4us.net Disconnect the heater hose quick connect fitting.

www.4x4us.net

1. Using the **J 43181** disconnect the inlet heater hose from the heater core. See Special Tools and

Equipment .

www.4x4us.net

www.4x4us.net

2. Install the J 45181 to the heater core outlet pipe. See **Special Tools and Equipment** .
3. Close the tool around the heater core outlet pipe.
4. Firmly pull the tool into the quick connect end of the heater hose.
5. Firmly grasp the heater hose. Pull the heater hose forward in order to disengage the hose from the heater core.

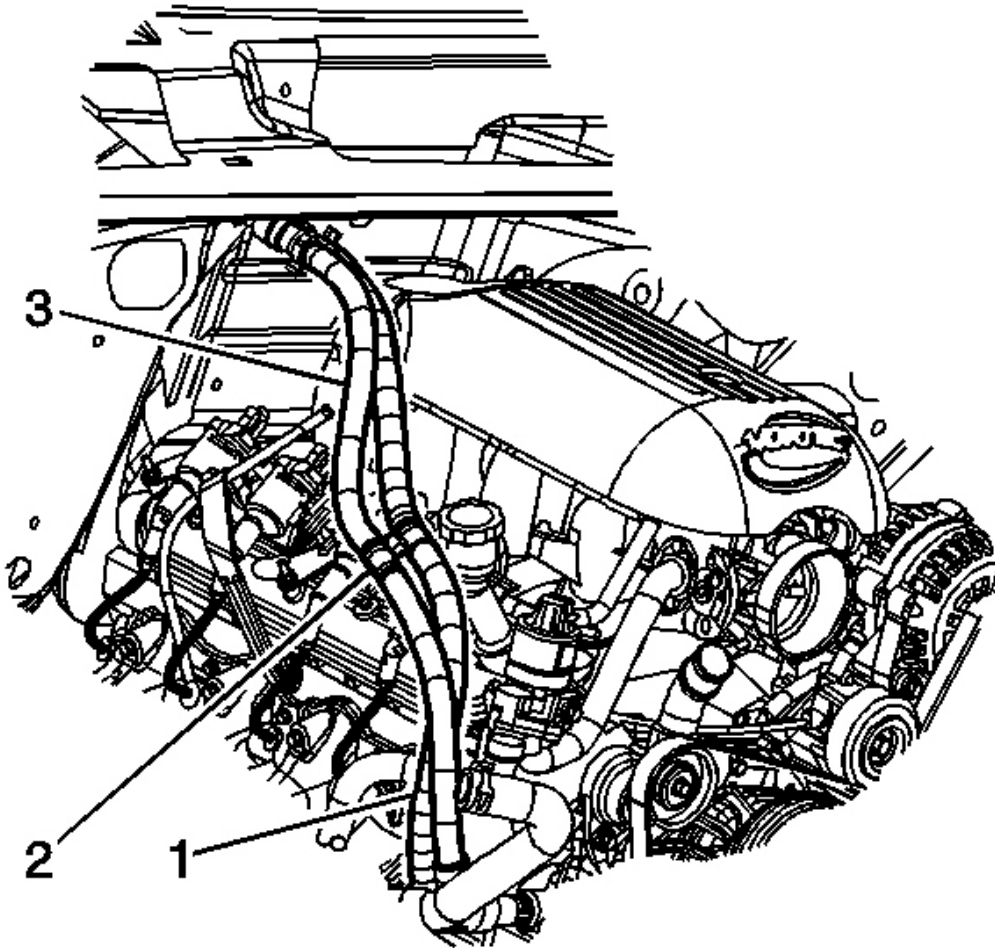

Fig. 16: Heater Hose & Mounting Clip
Courtesy of GENERAL MOTORS CORP.

4. Remove the heater hose (3) from the mounting clip (2).

www.4x4us.net

www.4x4us.net

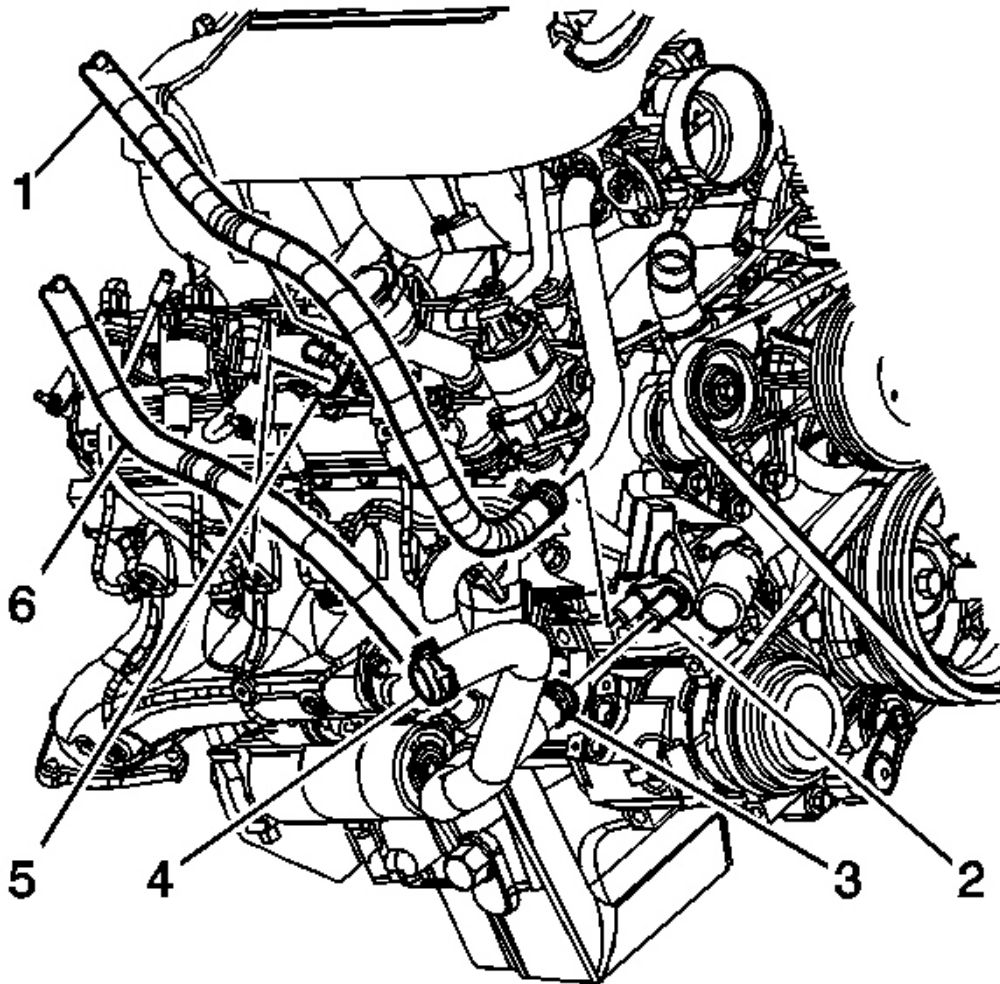

Fig. 17: Surge Tank Hose & Engine (Outlet)
Courtesy of GENERAL MOTORS CORP.

5. Reposition the surge tank outlet hose clamp (3) from the engine (2).
6. Remove the surge tank outlet hose (6) from the engine (2).

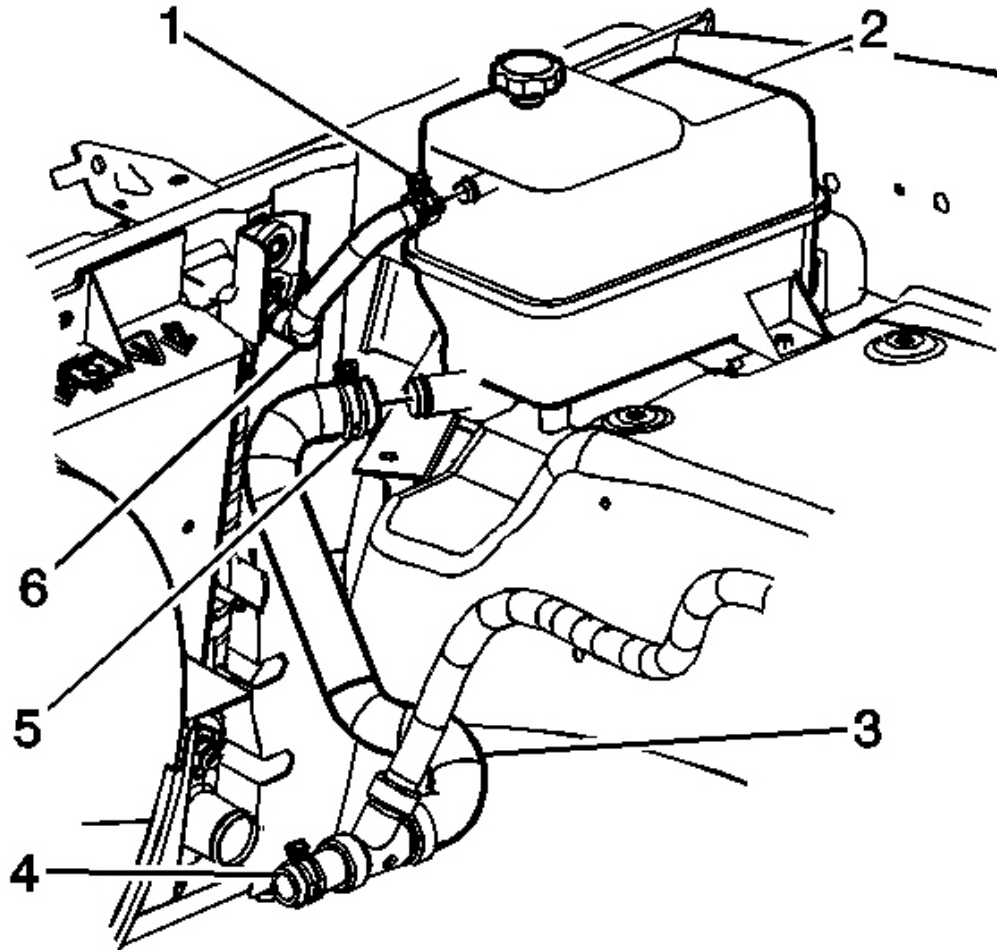

Fig. 18: Surge Tank Components
Courtesy of GENERAL MOTORS CORP.

7. Reposition the surge tank outlet hose clamp (5) from the surge tank (2).
8. Remove the surge tank outlet hose (3) from the surge tank (2).
9. Remove the surge tank outlet hose (3) from the vehicle.

Installation Procedure

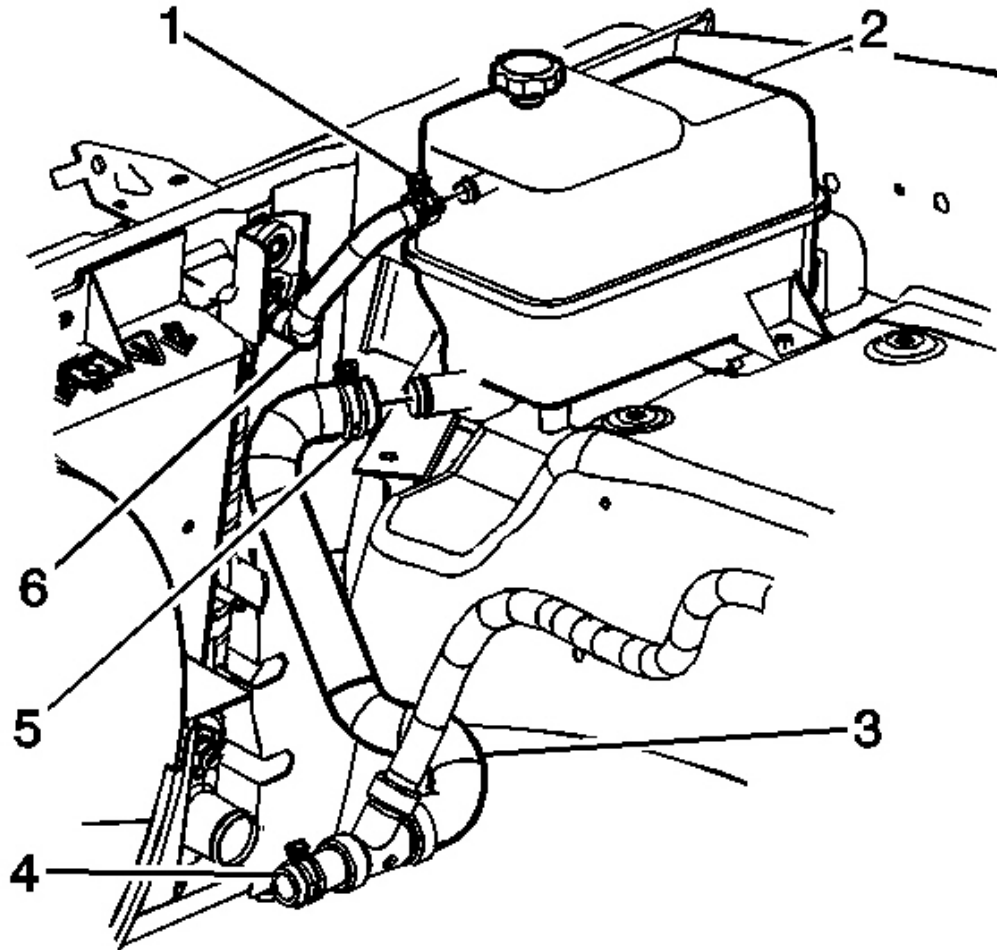

Fig. 19: Surge Tank Components
Courtesy of GENERAL MOTORS CORP.

1. Install the surge tank outlet hose (3) to the vehicle.
2. Install the surge tank outlet hose (3) to the surge tank (2).
3. Reposition the surge tank outlet hose clamp (5) to the surge tank (2).

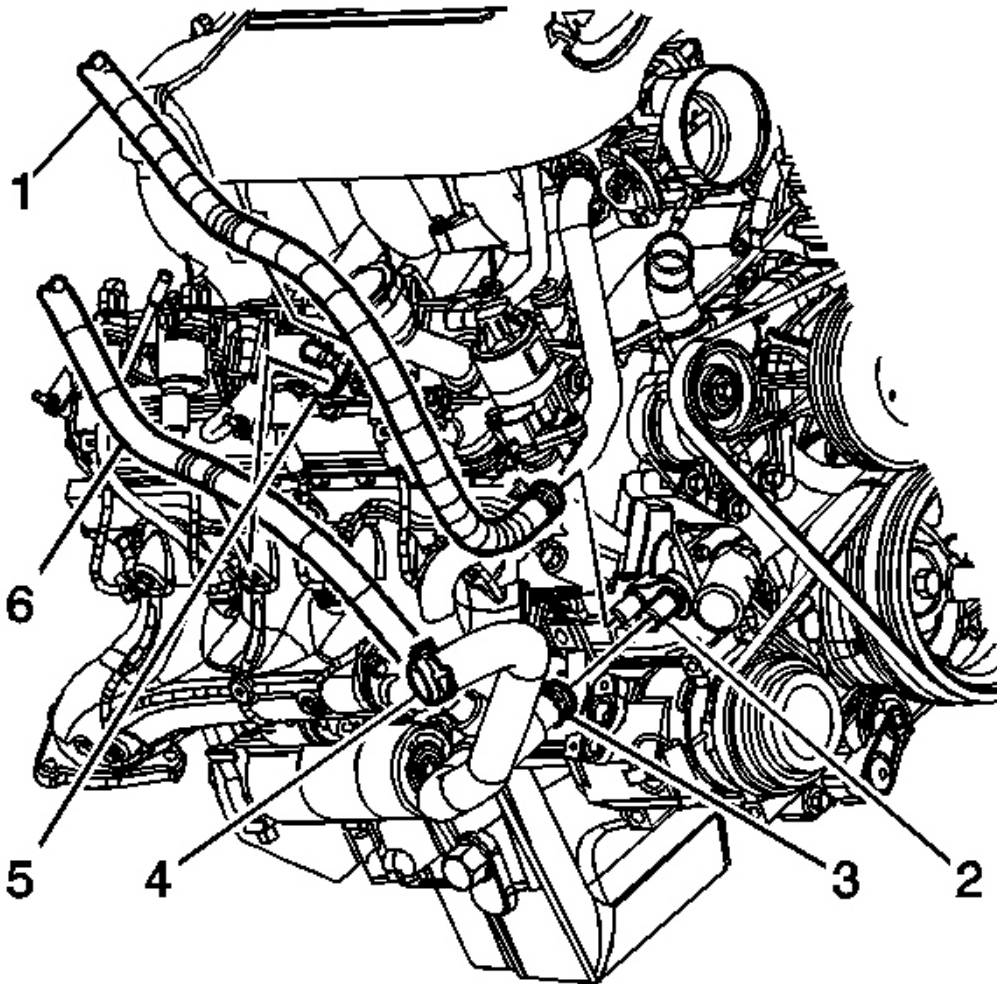

Fig. 20: Surge Tank Hose & Engine (Outlet)
Courtesy of GENERAL MOTORS CORP.

4. Install the surge tank outlet hose (6) to the engine (2).
5. Reposition the surge tank outlet hose clamp (3) to the engine (2).
6. Connect the heater inlet hose to the heater core.

IMPORTANT: Firmly push the quick connect onto the heater core pipe until you hear an audible click.

7. Pull the heater inlet hose to ensure the connection.

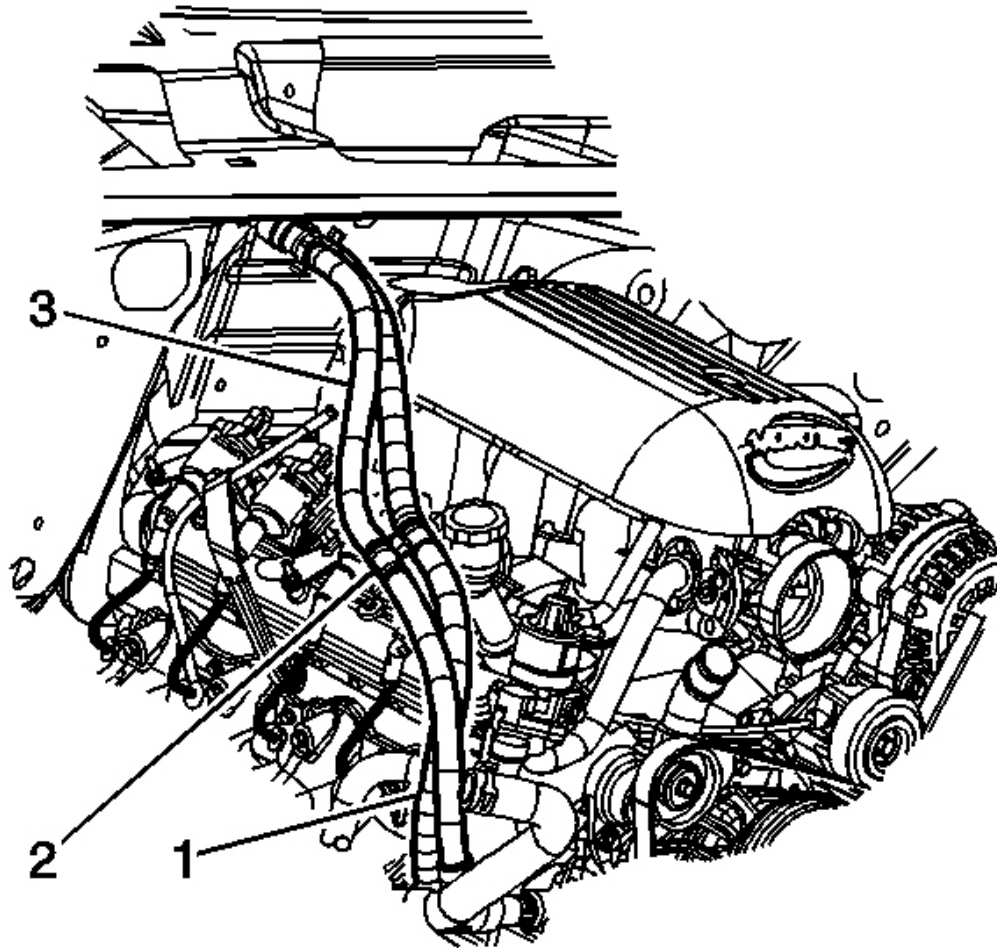

Fig. 21: Heater Hose & Mounting Clip
Courtesy of GENERAL MOTORS CORP.

8. Install the heater hose (3) to the mounting clip (2).

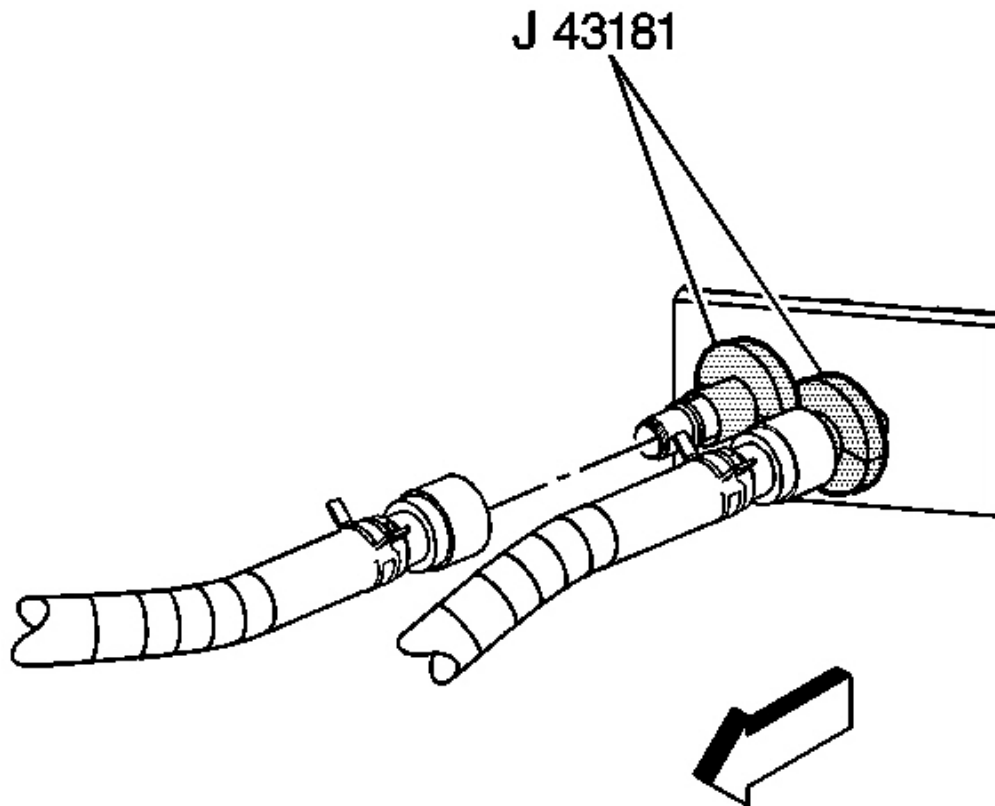

Fig. 22: Identifying Heater Hose To Heater Core Outlet
Courtesy of GENERAL MOTORS CORP.

IMPORTANT: Firmly push the quick connect onto the heater core pipe until you hear an audible click.

9. Connect the surge tank outlet hose to the heater core outlet pipe.
10. Pull the surge tank outlet hose to ensure the connection.
11. Install the air cleaner resonator outlet duct. Refer to [Air Cleaner Resonator Outlet Duct Replacement](#) in Engine Controls - 4.8L, 5.3L and 6.0L.
12. Fill the cooling system. Refer to [Draining and Filling Cooling System](#) .

RADIATOR HOSE REPLACEMENT - INLET

1. Drain the cooling system. Refer to Draining and Filling Cooling System . www.4x4us.net
2. Remove the air cleaner resonator outlet duct. Refer to Air Cleaner Resonator Outlet Duct Replacement in Engine Controls - 4.8L, 5.3L and 6.0L.

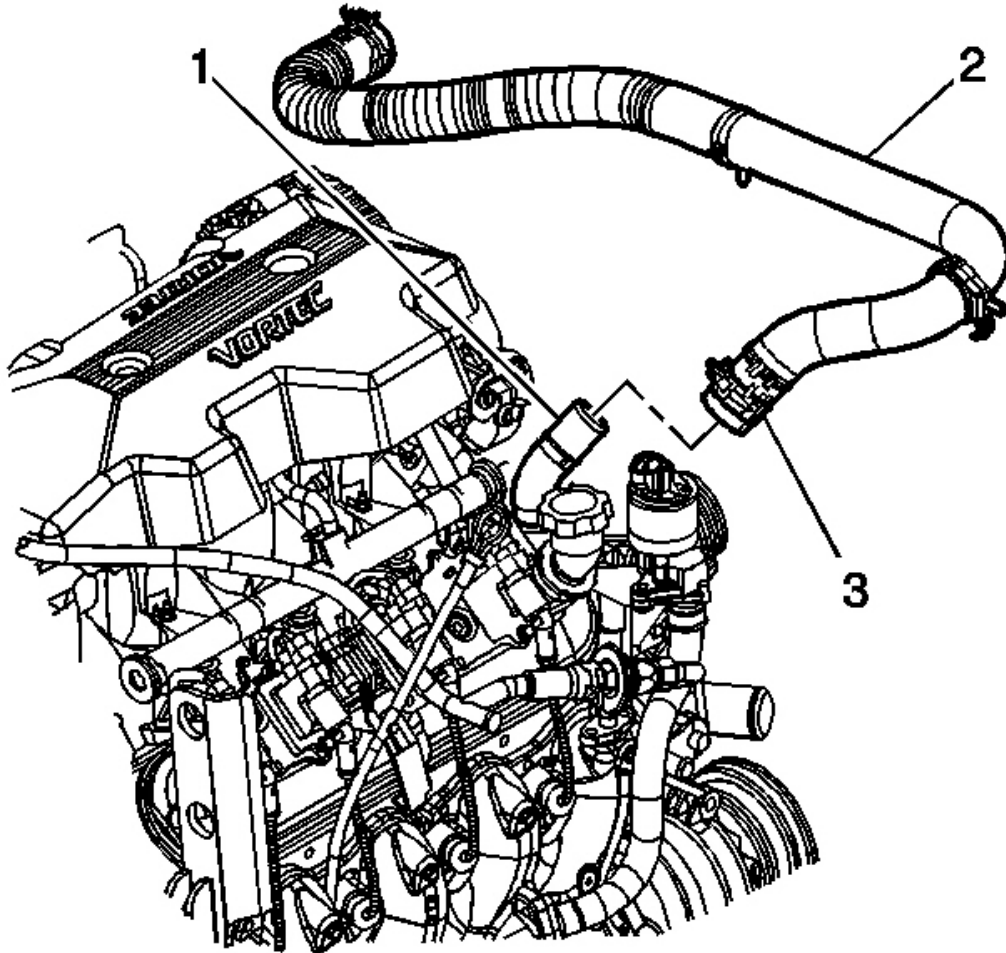

Fig. 23: Radiator Hose & Engine (Inlet)
Courtesy of GENERAL MOTORS CORP.

3. Reposition the radiator inlet hose clamp (3) from the engine (1).
 4. Remove the radiator inlet hose (2) from the engine (1).
 5. Remove the radiator inlet hose (4) from the mounting clip (3).
- www.4x4us.net

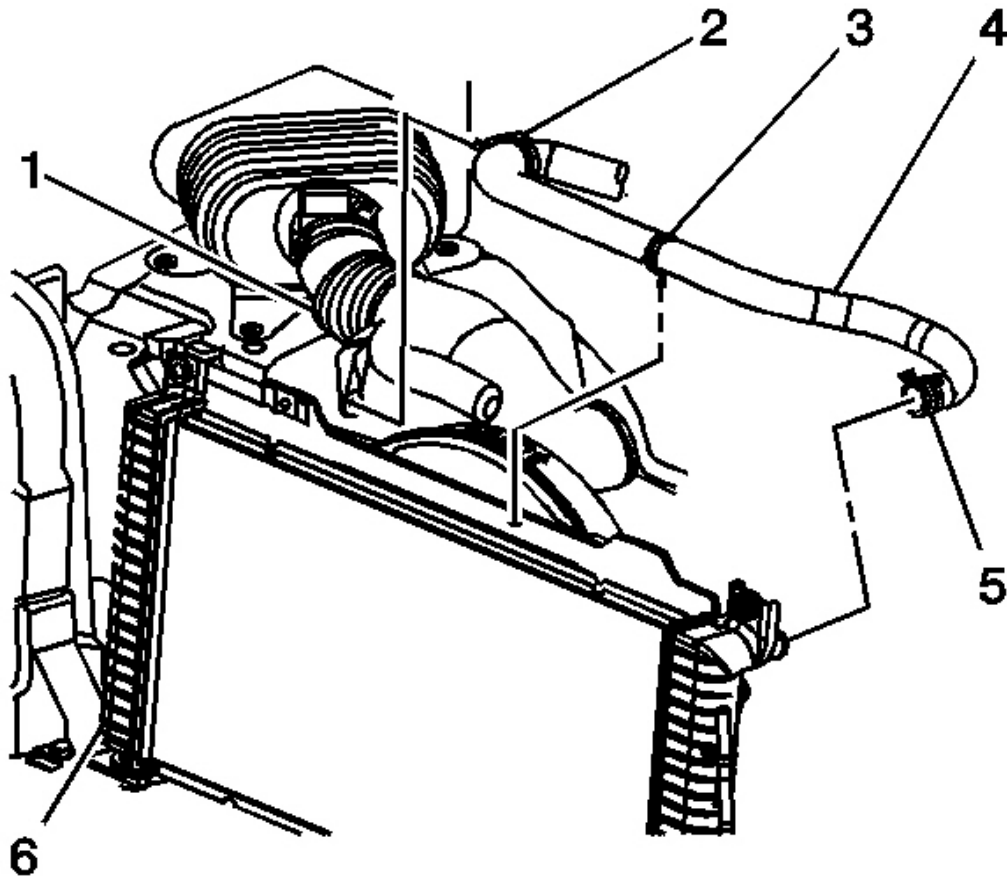

Fig. 24: Radiator Hose & Radiator (Inlet)
Courtesy of GENERAL MOTORS CORP.

6. Reposition the radiator inlet hose clamp (5) from the radiator (6).
7. Remove the radiator inlet hose (4) from the radiator (6).
8. Remove the inlet hose from the vehicle.

Installation Procedure

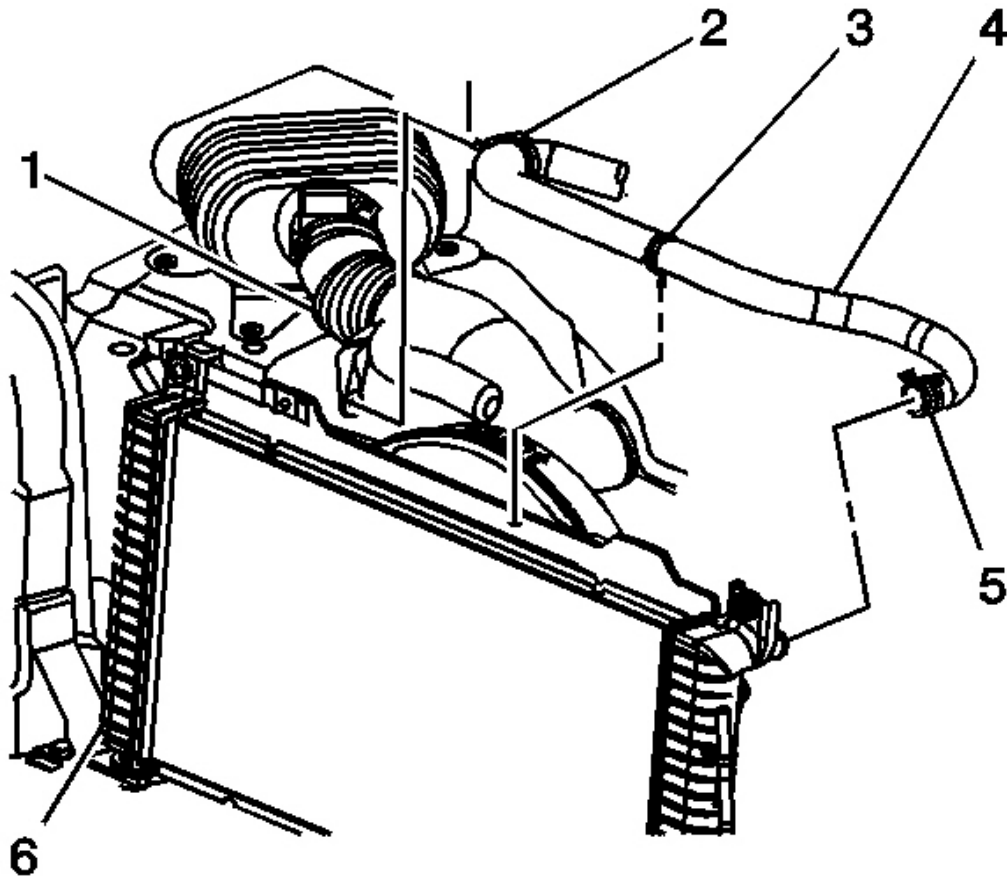

Fig. 25: Radiator Hose & Radiator (Inlet)
Courtesy of GENERAL MOTORS CORP.

1. Install the radiator inlet hose (4) to the radiator (6).
2. Position the radiator inlet hose clamp (5) to the radiator (6).
3. Install the radiator inlet hose (4) to the mounting clip (3).
4. Install the radiator inlet hose (2) to the engine (1).

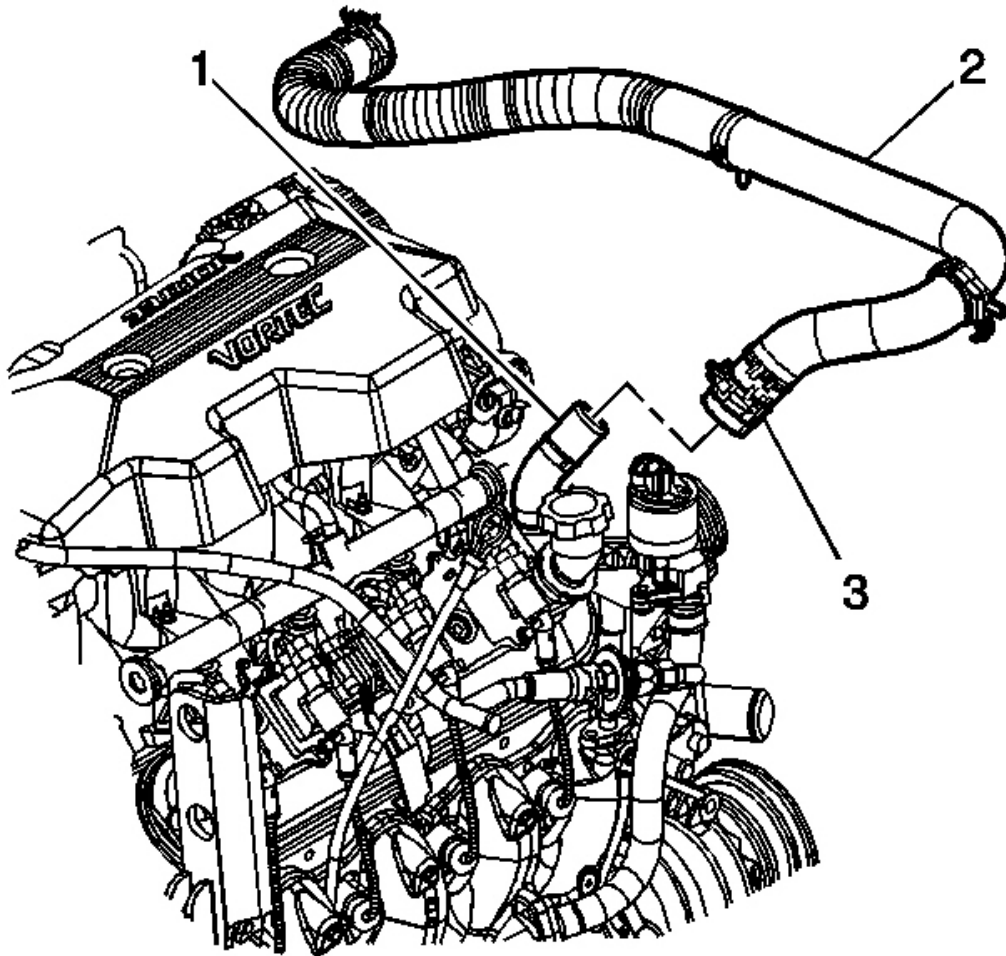

Fig. 26: Radiator Hose & Engine (Inlet)
Courtesy of GENERAL MOTORS CORP.

Position the radiator inlet hose clamp (3) to the engine (1).

5. Install the air cleaner resonator outlet duct. Refer to [Air Cleaner Resonator Outlet Duct Replacement](#) in Engine Controls - 4.8L, 5.3L and 6.0L.
6. Fill the cooling system. Refer to [Draining and Filling Cooling System](#) .

RADIATOR HOSE REPLACEMENT - OUTLET

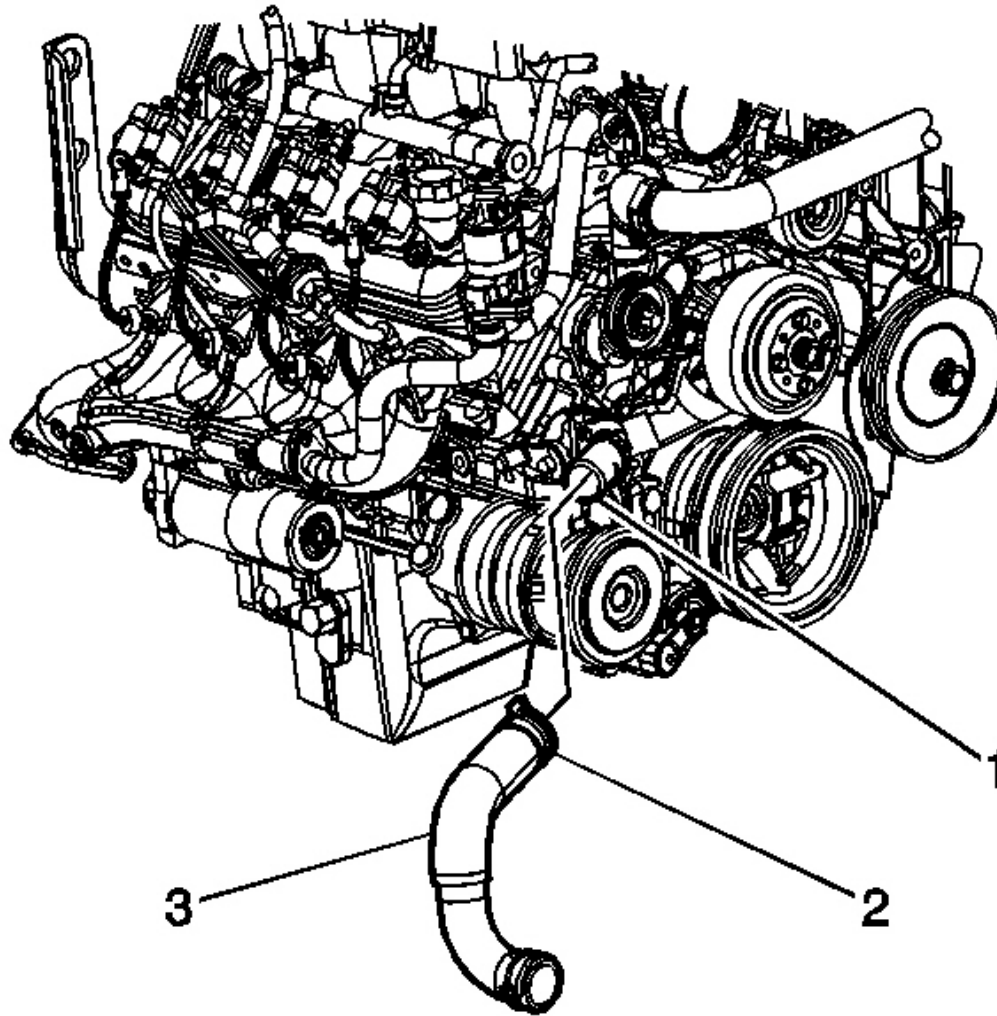

Fig. 27: Radiator Hose & Engine (Outlet)
Courtesy of GENERAL MOTORS CORP.

1. Drain the cooling system. Refer to **Draining and Filling Cooling System** .
2. Remove the air cleaner resonator outlet duct. Refer to **Air Cleaner Resonator Outlet Duct Replacement** in Engine Controls - 4.8L, 5.3L and 6.0L.
3. Reposition the radiator outlet hose clamp (2) from the engine (1).
4. Remove the radiator outlet hose (3) from the engine (1).

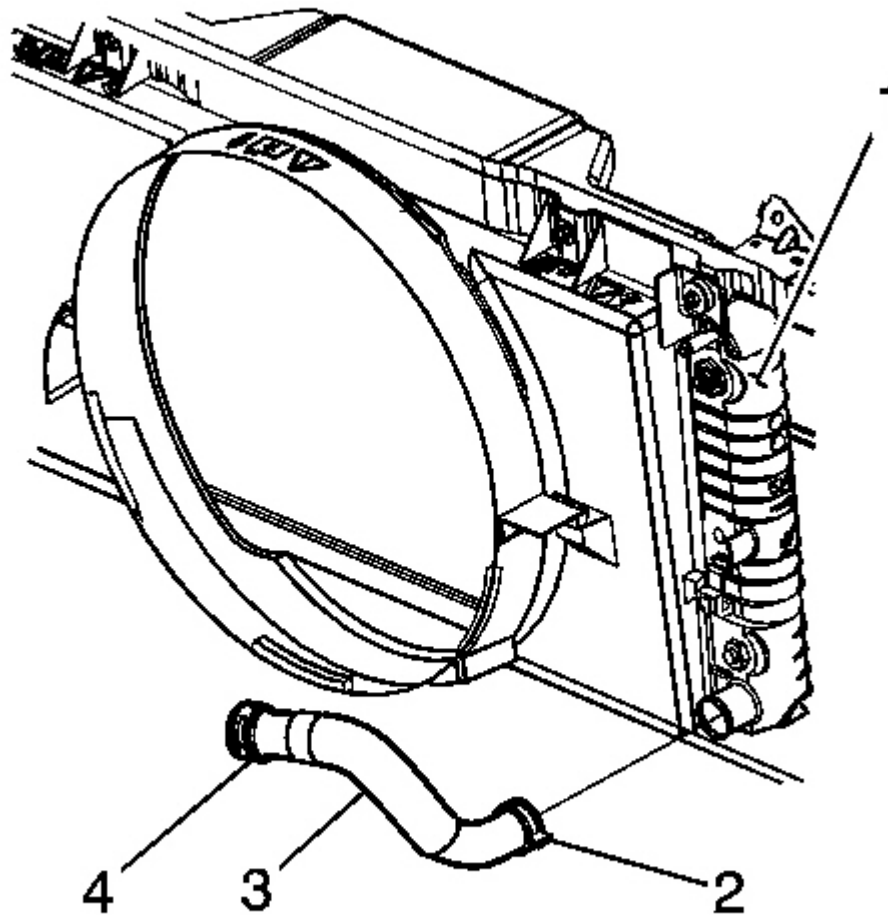

Fig. 28: Radiator Hose & Radiator (Outlet)
Courtesy of GENERAL MOTORS CORP.

5. Reposition the radiator outlet hose clamp (2) from the radiator (1).
6. Remove the radiator outlet hose (3) from the radiator (1).
7. Remove the outlet hose from the vehicle.

Installation Procedure

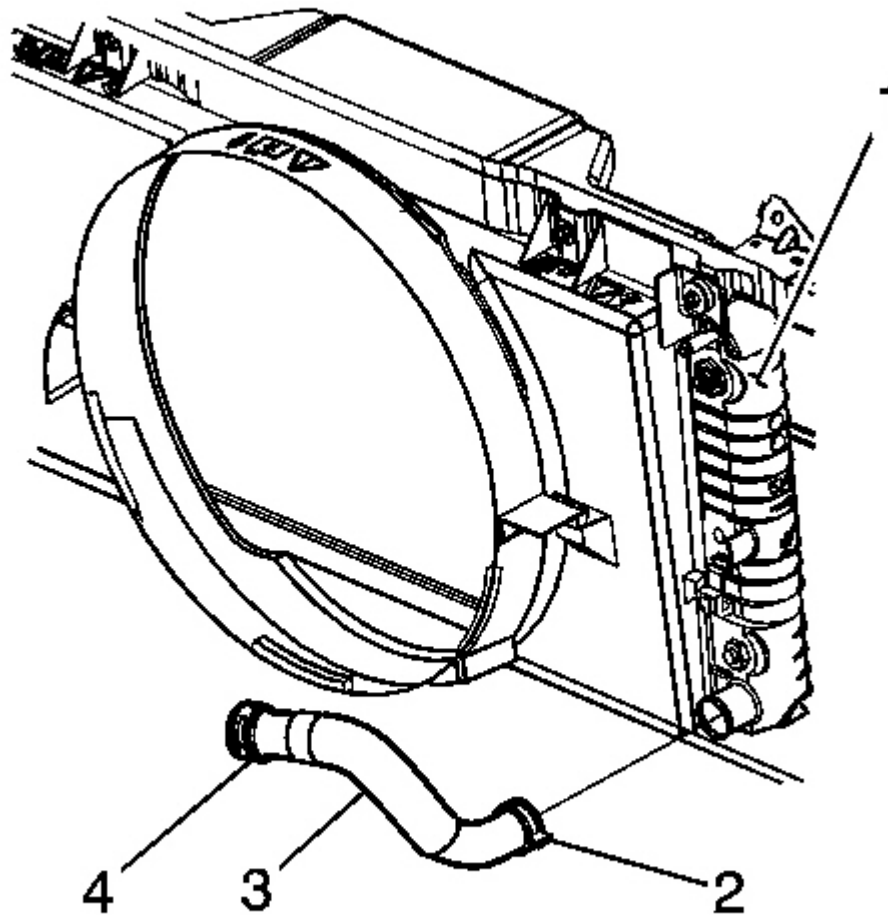

Fig. 29: Radiator Hose & Radiator (Outlet)
Courtesy of GENERAL MOTORS CORP.

1. Install the radiator outlet hose (3) to the radiator (1).
2. Position the radiator outlet hose clamp (2) to the radiator (1).

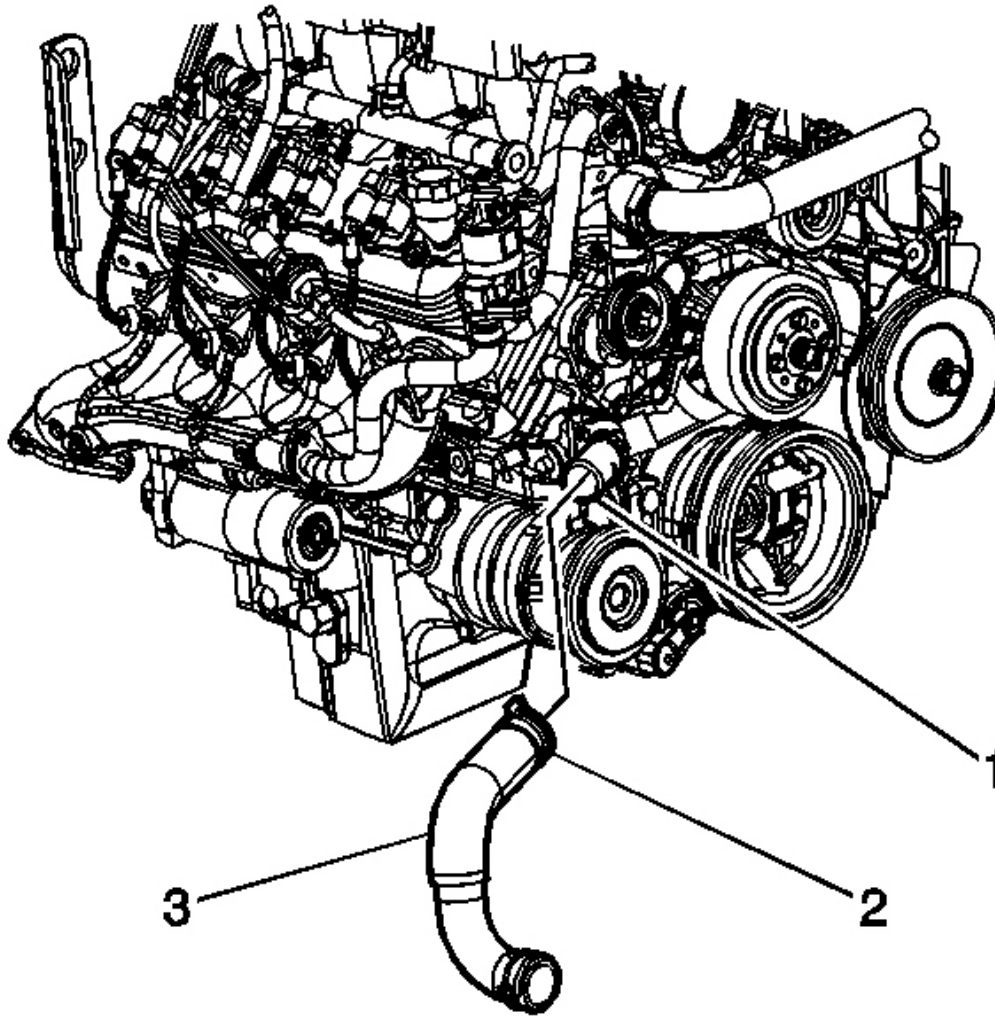

Fig. 30: Radiator Hose & Engine (Outlet)
Courtesy of GENERAL MOTORS CORP.

3. Install the radiator outlet hose (3) to the engine (1).
4. Position the radiator outlet hose clamp (2) to the engine (1).
5. Install the air cleaner resonator outlet duct. Refer to [Air Cleaner Resonator Outlet Duct Replacement](#) in Engine Controls - 4.8L, 5.3L and 6.0L.
6. Fill the cooling system. Refer to [Draining and Filling Cooling System](#) .

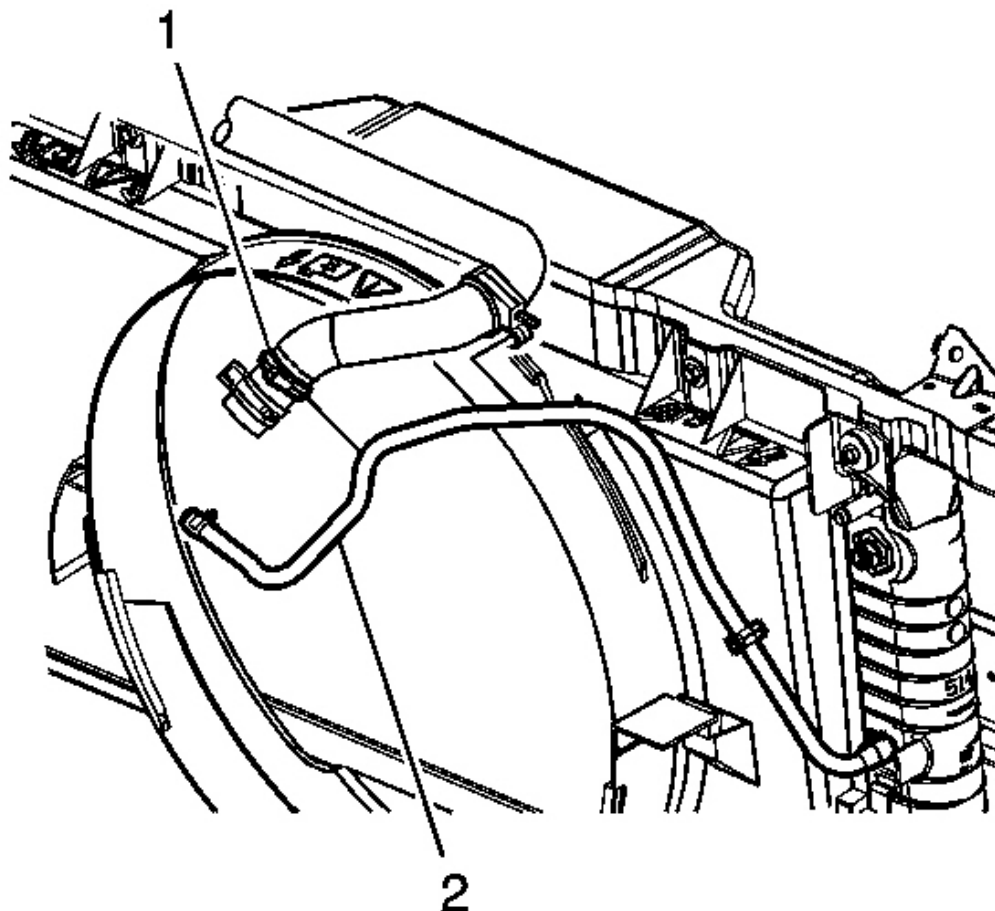

Fig. 31: Radiator Vent Inlet Hose
Courtesy of GENERAL MOTORS CORP.

1. Drain the cooling system. Refer to **Draining and Filling Cooling System** .
2. Remove the air cleaner resonator outlet duct. Refer to **Air Cleaner Resonator Outlet Duct Replacement** in Engine Controls - 4.8L, 5.3L and 6.0L.
3. Reposition the radiator vent inlet hose clamp from the radiator.
4. Remove the radiator vent inlet hose (2) from the radiator.
5. Remove the radiator vent inlet hose (2) from the fan shroud retainer.
6. Reposition the radiator vent inlet hose clamp from the throttle body.
7. Remove the radiator vent inlet hose (2) from the throttle body.

8. Remove the vent inlet hose from the vehicle.

www.4x4us.net

www.4x4us.net

Installation Procedure

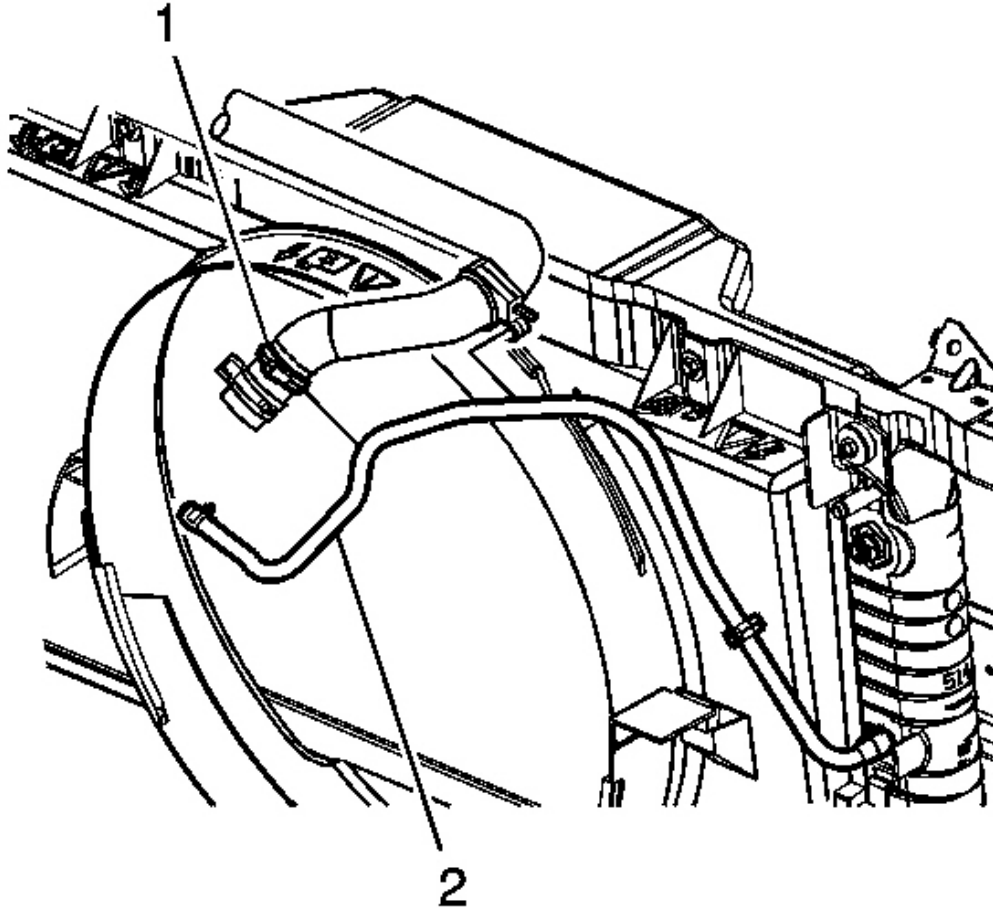

Fig. 32: Radiator Vent Inlet Hose
Courtesy of GENERAL MOTORS CORP.

1. Install the radiator vent inlet hose (2) to the throttle body.
2. Install the radiator vent inlet hose clamp to the throttle body.
3. Install the radiator vent inlet hose (2) to the fan shroud retainer.
4. Install the radiator vent inlet hose (2) to the radiator.

www.4x4us.net

www.4x4us.net

6. Install the air cleaner resonator outlet duct. Refer to **Air Cleaner Resonator Outlet Duct Replacement**

in Engine Controls - 4.8L, 5.3L and 6.0L.

7. Fill the cooling system. Refer to [Draining and Filling Cooling System](#).

www.4x4us.net

www.4x4us.net

ENGINE OIL COOLER PIPE/HOSE QUICK CONNECT FITTING

Removal Procedure

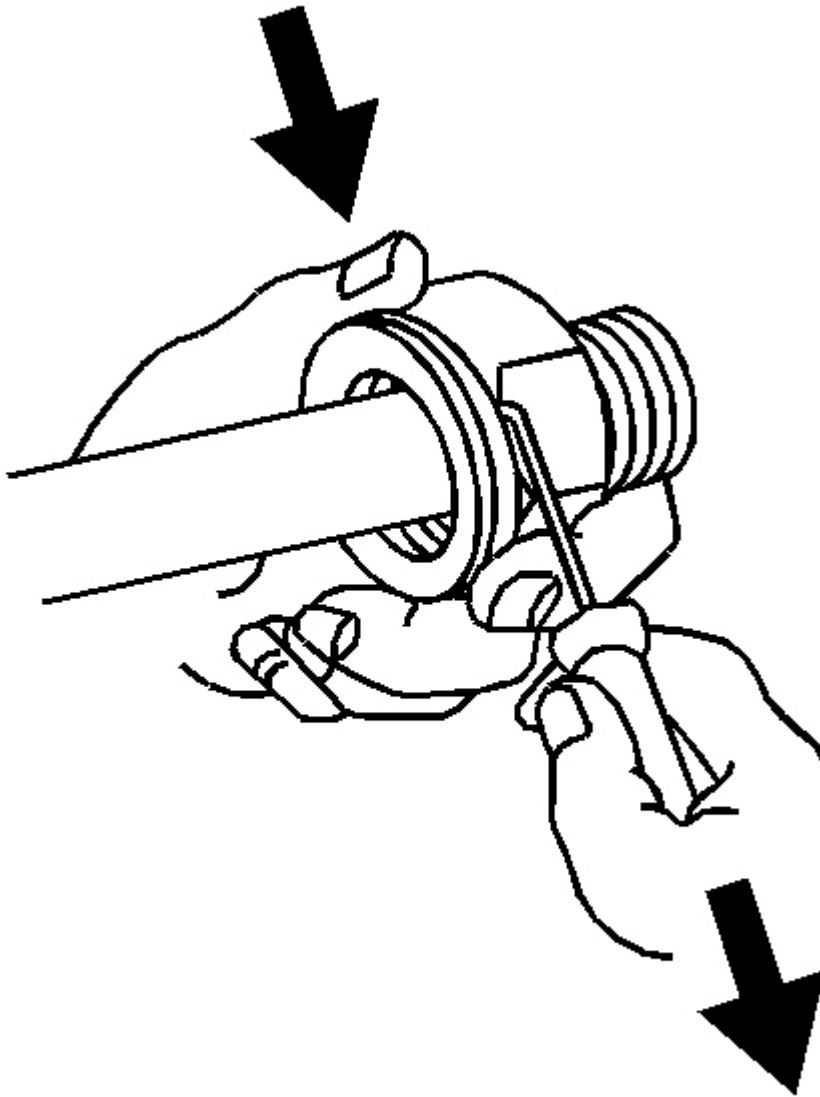

www.4x4us.net

www.4x4us.net

Fig. 33: Rotating Retaining Ring

Courtesy of GENERAL MOTORS CORP.

www.4x4us.net

www.4x4us.net

1. Disengage the plastic caps from the quick connect fittings. Pull the caps back along the pipe.
2. Using a bent-tip screwdriver or equivalent, pull on one of the open ends of the retaining ring in order to rotate the retaining ring.
3. Rotate the retaining ring around the quick connector until the retaining ring is out of position and can be completely removed.

Discard the retaining rings.

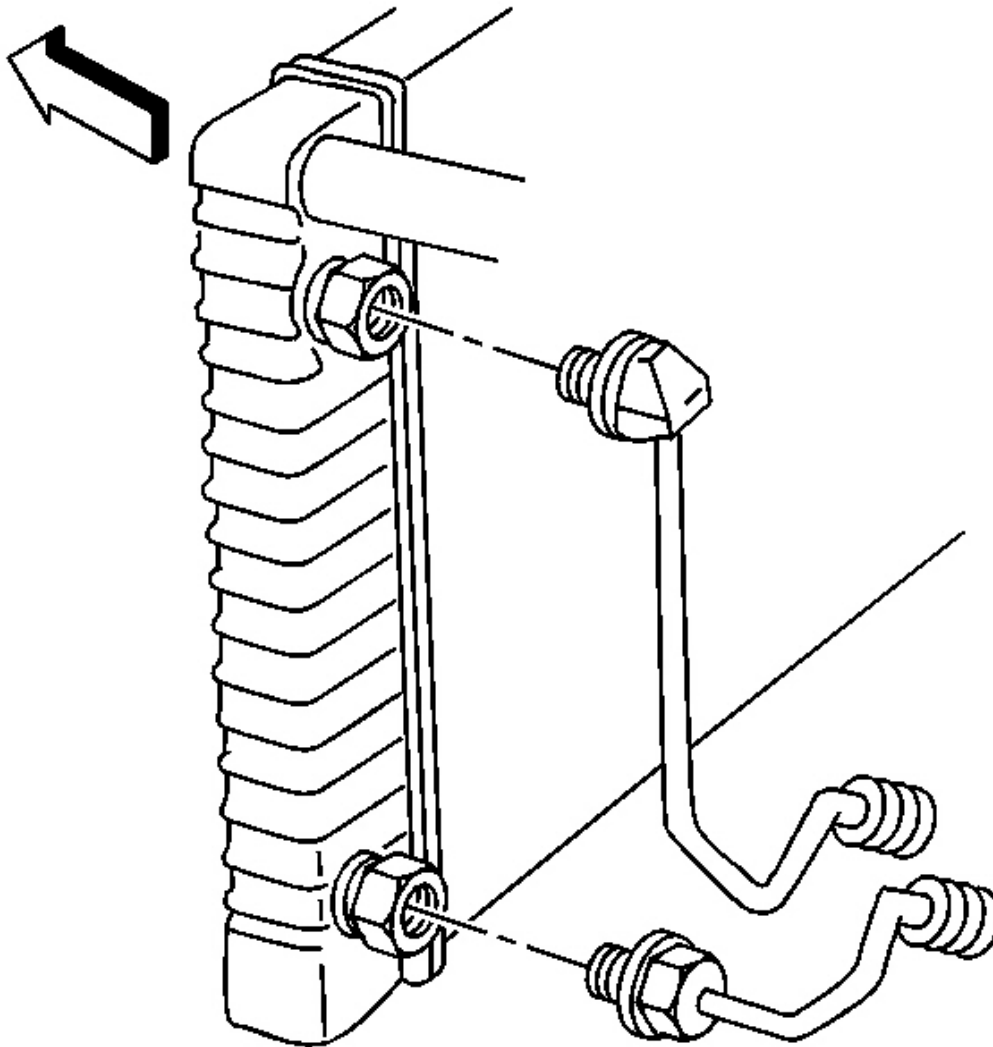

www.4x4us.net

www.4x4us.net

Fig. 34: Engine Oil Cooler Line

www.4x4us.net
Courtesy of GENERAL MOTORS CORP.

www.4x4us.net

4. Remove the engine oil cooler line from the quick connector fitting at the radiator.

Pull the lines straight out from the connectors.

5. Clean all of the components in a suitable solvent, and dry them with compressed air.
6. Inspect the fittings, the connectors, the cooler lines, and the cooler for damage, distortion, or restriction. Replace parts as necessary.

Installation Procedure

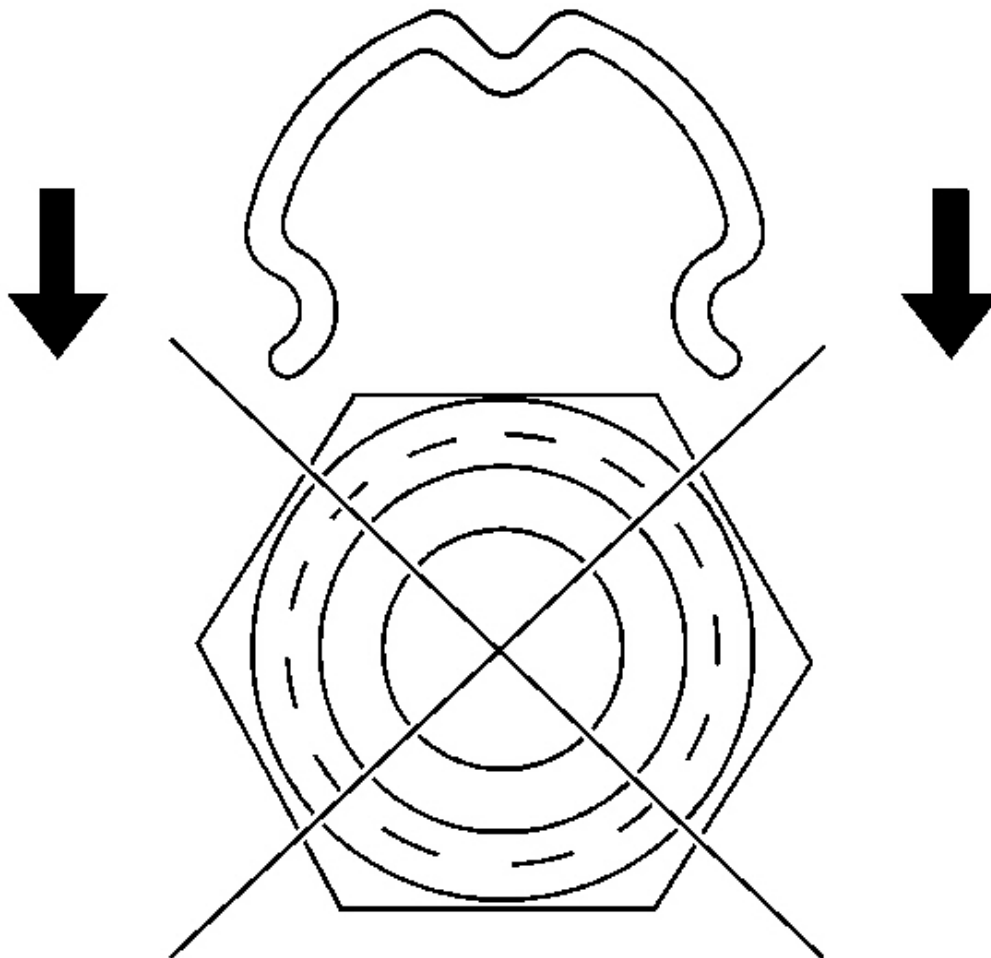

www.4x4us.net

www.4x4us.net

Fig. 35: Do Not Install Retaining Ring In This Manner

www.4x4us.net
Courtesy of GENERAL MOTORS CORP.

www.4x4us.net

IMPORTANT: When performing the following procedure, do not reuse the old retaining rings. Replace the old retaining rings with new ones.
Do not install the new retaining ring onto the fitting by pushing the retaining ring down over the fitting.

1. Install a new retaining ring into each quick connector fitting.

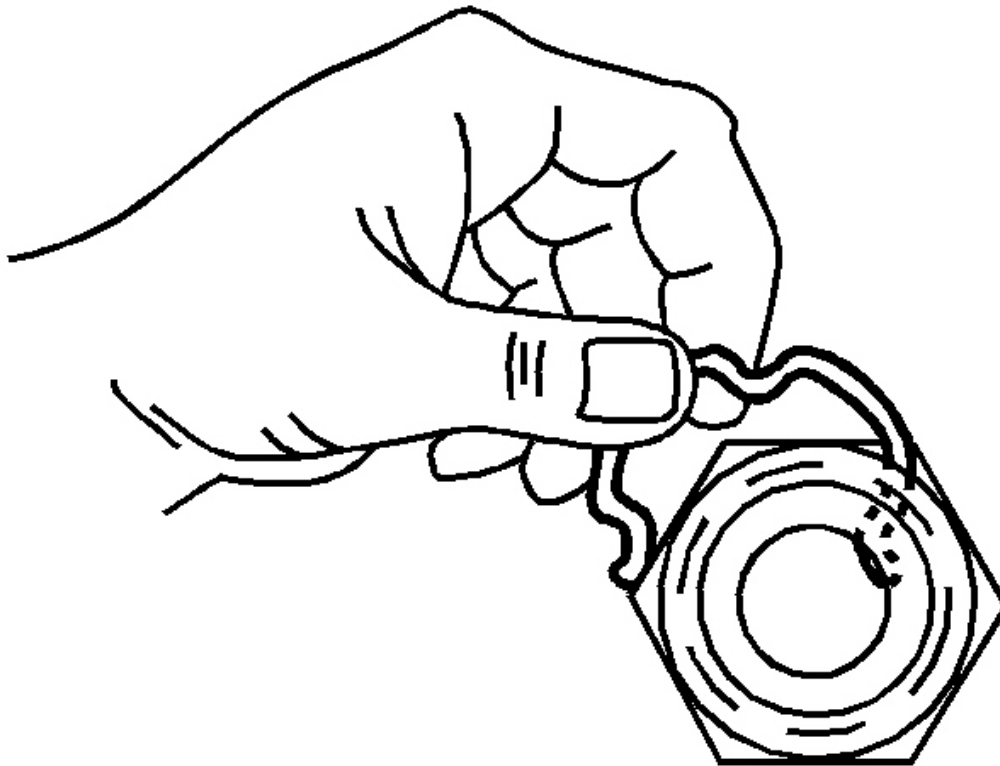

Fig. 36: Hooking Retaining Ring

Courtesy of GENERAL MOTORS CORP.

2. Hook one of the open ends of the retaining ring in one of the slots in the quick connector.

www.4x4us.net

www.4x4us.net

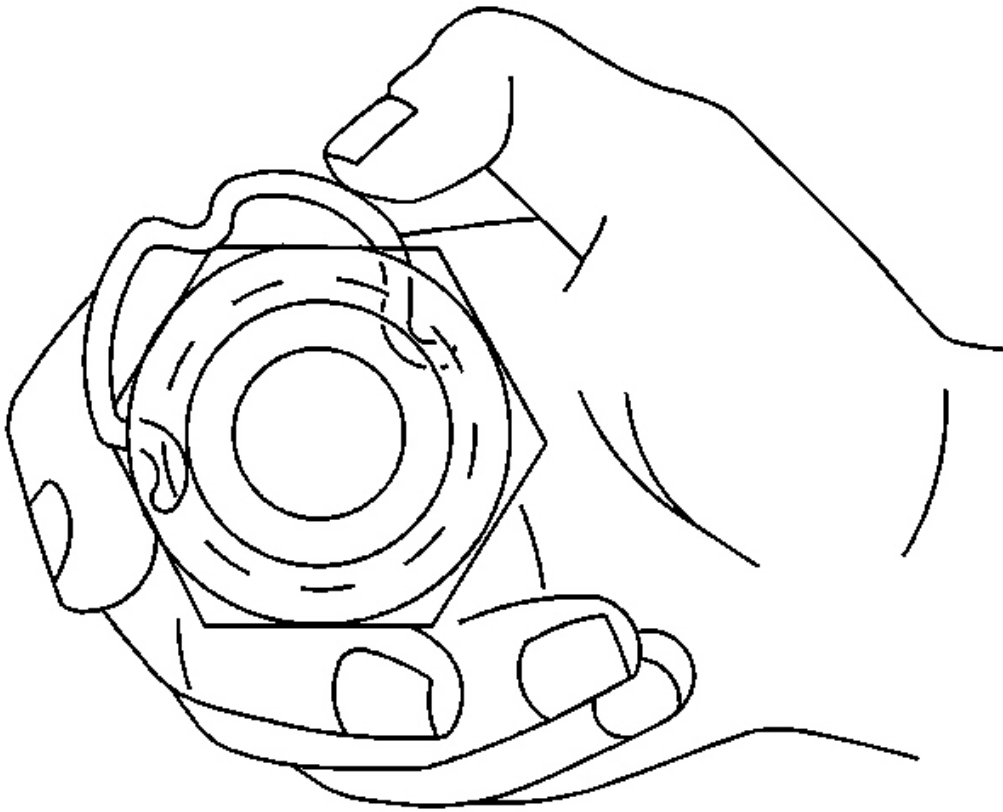

Fig. 37: Rotating Retaining Ring Around Connector
Courtesy of GENERAL MOTORS CORP.

3. Rotate the retaining ring around the connector until the retaining ring is positioned with all 3 ears through the 3 slots.

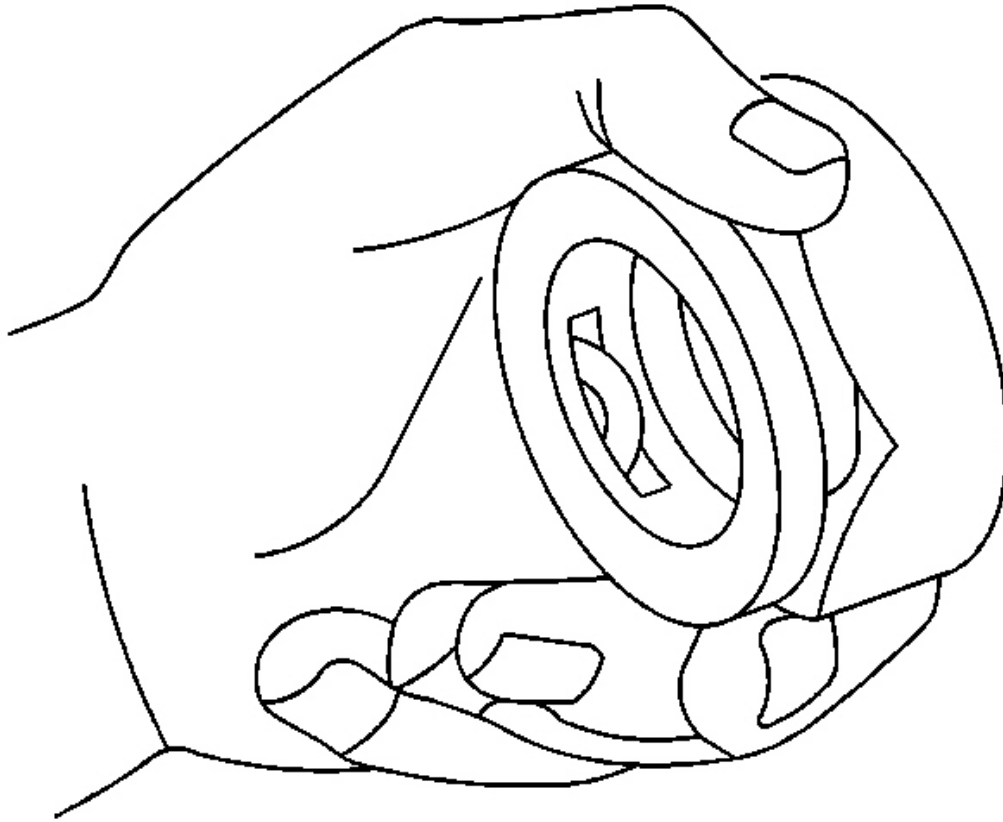

Fig. 38: Ensuring Retaining Ring Ears Are Seen From Inside Of Connector & Retaining Ring
Courtesy of GENERAL MOTORS CORP.

4. Ensure the 3 retaining ring ears can be seen from the inside of the connector and the retaining ring can move freely in the slots.

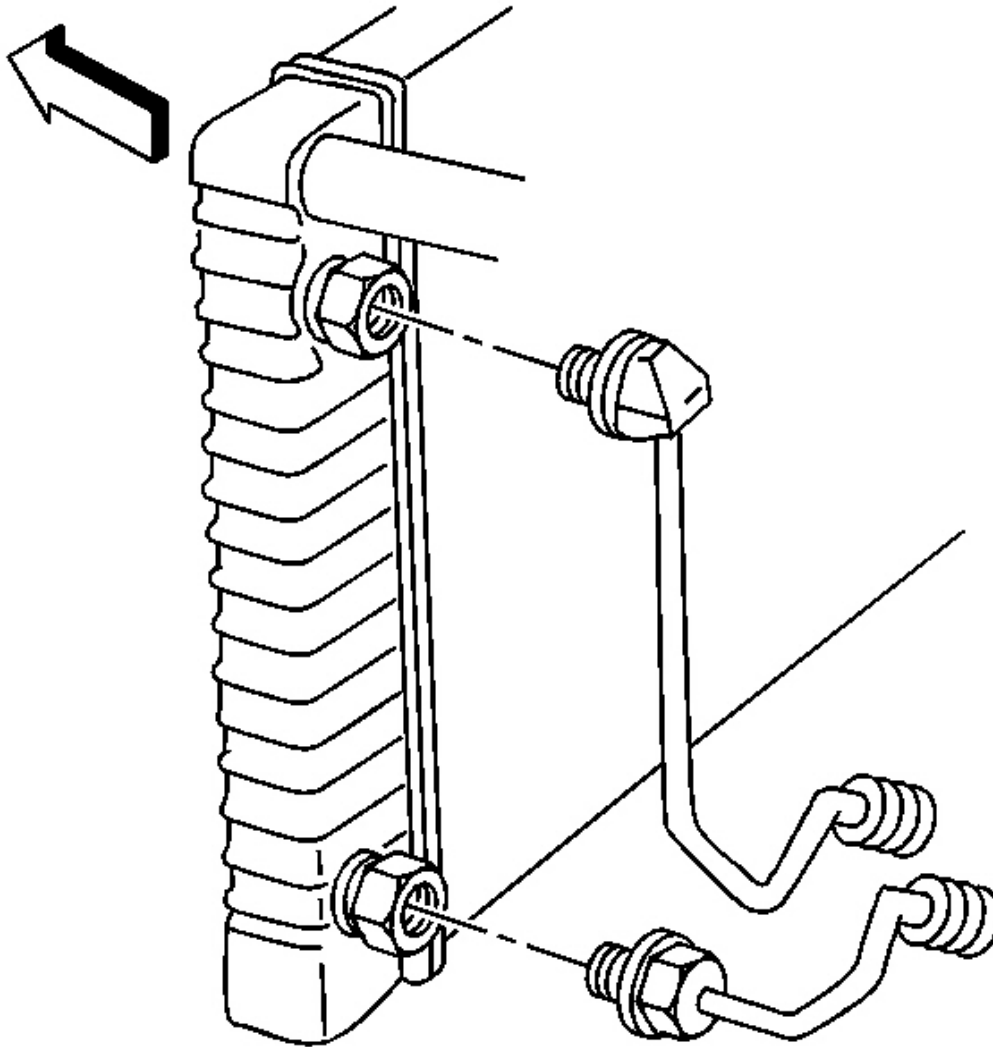

Fig. 39: Engine Oil Cooler Line
Courtesy of GENERAL MOTORS CORP.

5. Install the engine oil cooler line into the quick connector fitting until a click is heard or felt.

Pull back on the engine oil cooler lines to ensure a proper connection.

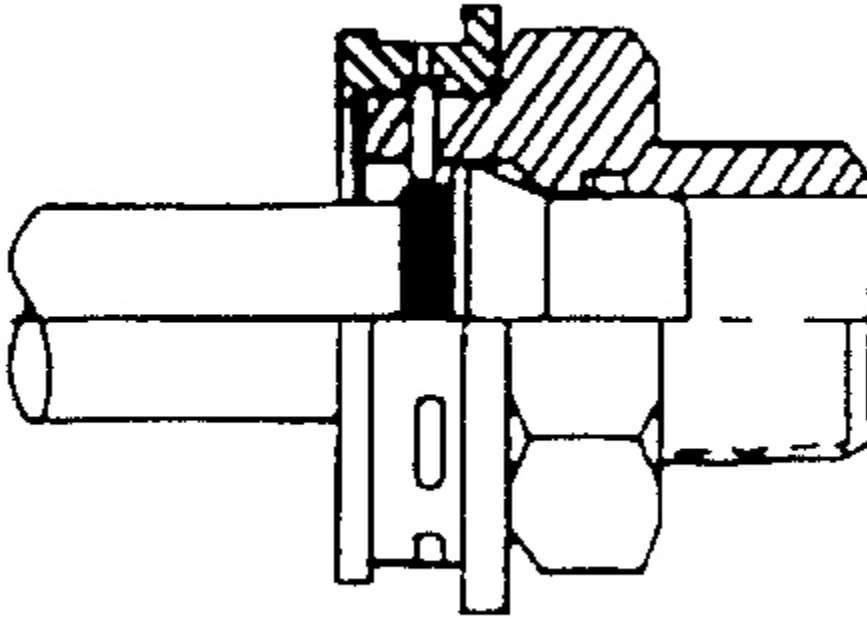

Fig. 40: Inserting Plastic Cap Onto Fitting
Courtesy of GENERAL MOTORS CORP.

IMPORTANT: Do not manually depress the retaining clip when installing the plastic cap.

6. Snap the plastic cap onto the quick connect fitting.
7. Ensure that the plastic cap is fully seated against the fitting.

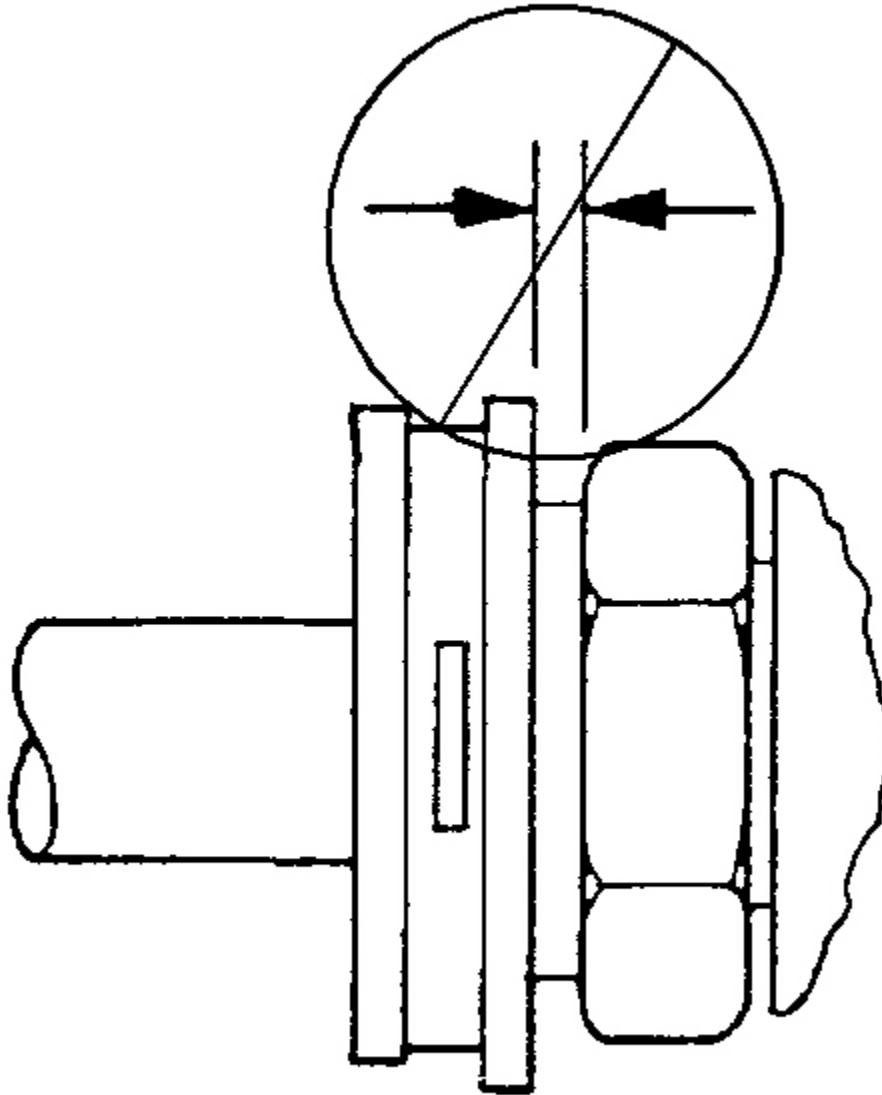

Fig. 41: Ensuring That No Gap Is Present Between Cap & Fitting
Courtesy of GENERAL MOTORS CORP.

8. Ensure that no gap is present between the cap and the fitting.
9. Inspect and fill the engine oil to the proper level.

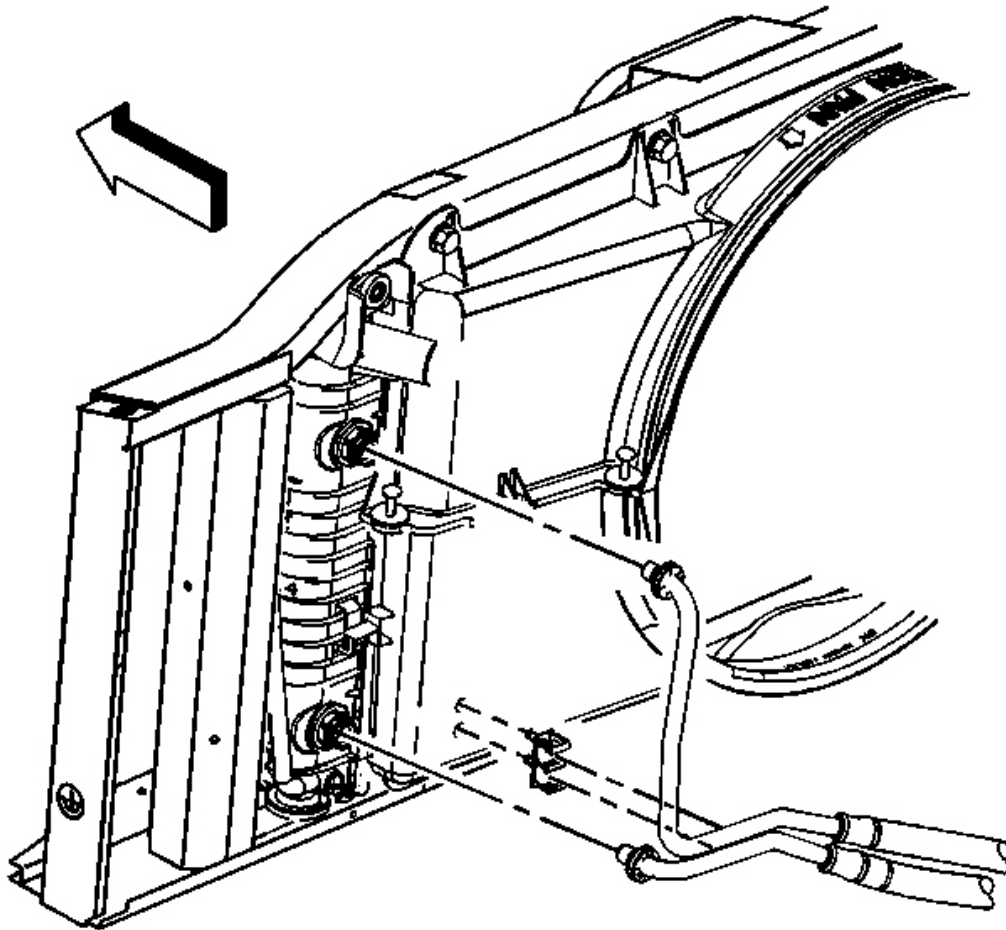

Fig. 42: Oil Cooler Hoses

Courtesy of GENERAL MOTORS CORP.

1. Remove the engine oil cooler hoses from the radiator. Refer to **Engine Oil Cooler Pipe/Hose Quick Connect Fitting** .
2. Remove the engine oil cooler hoses from the fan shroud.
3. Raise and suitably support the vehicle. Refer to **Lifting and Jacking the Vehicle** in General Information.
4. Remove the engine protection shield bolts.
5. Remove the engine shield.

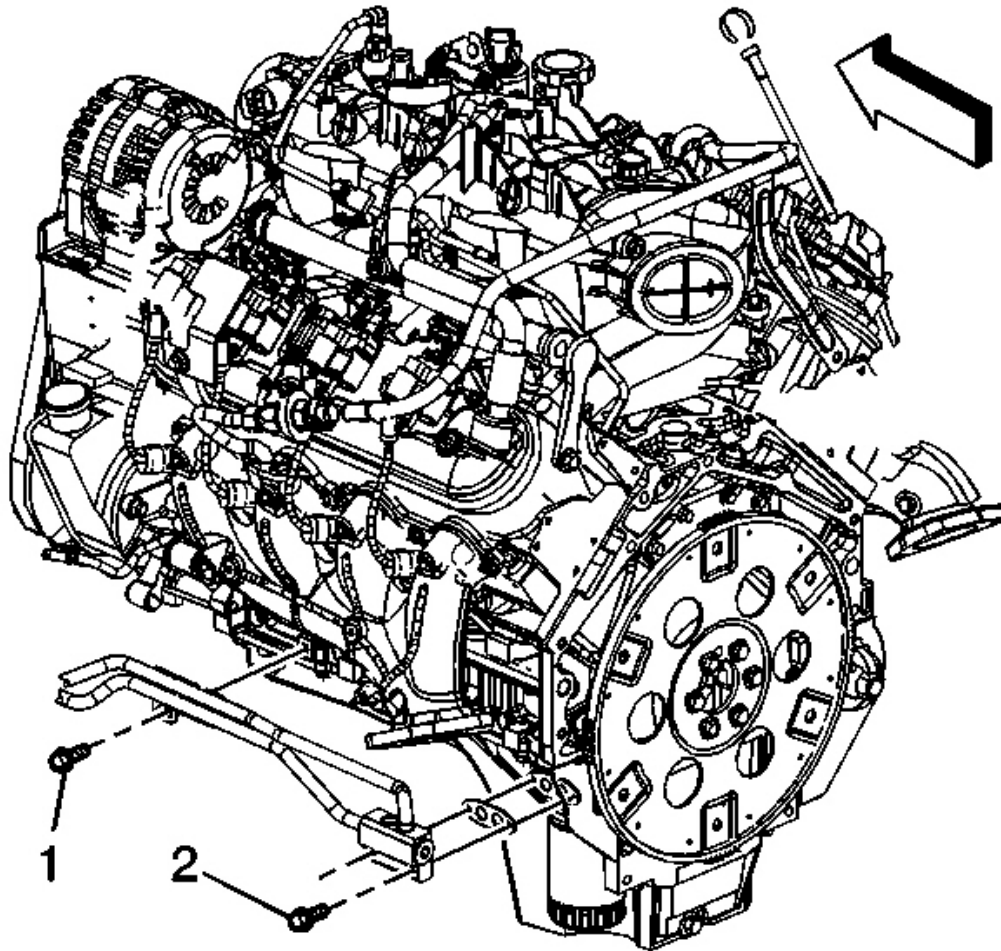

Fig. 43: Oil Cooler Hose Bracket Bolt & Adapter Bolts
Courtesy of GENERAL MOTORS CORP.

6. Remove the engine oil cooler hose bracket bolt (1).
7. Remove the engine oil cooler hose adapter bolts (2).
8. Remove the engine oil cooler hose assembly and gasket.

Discard the gasket.

9. Inspect the fittings, connectors and cooler hoses for damage or distortion.

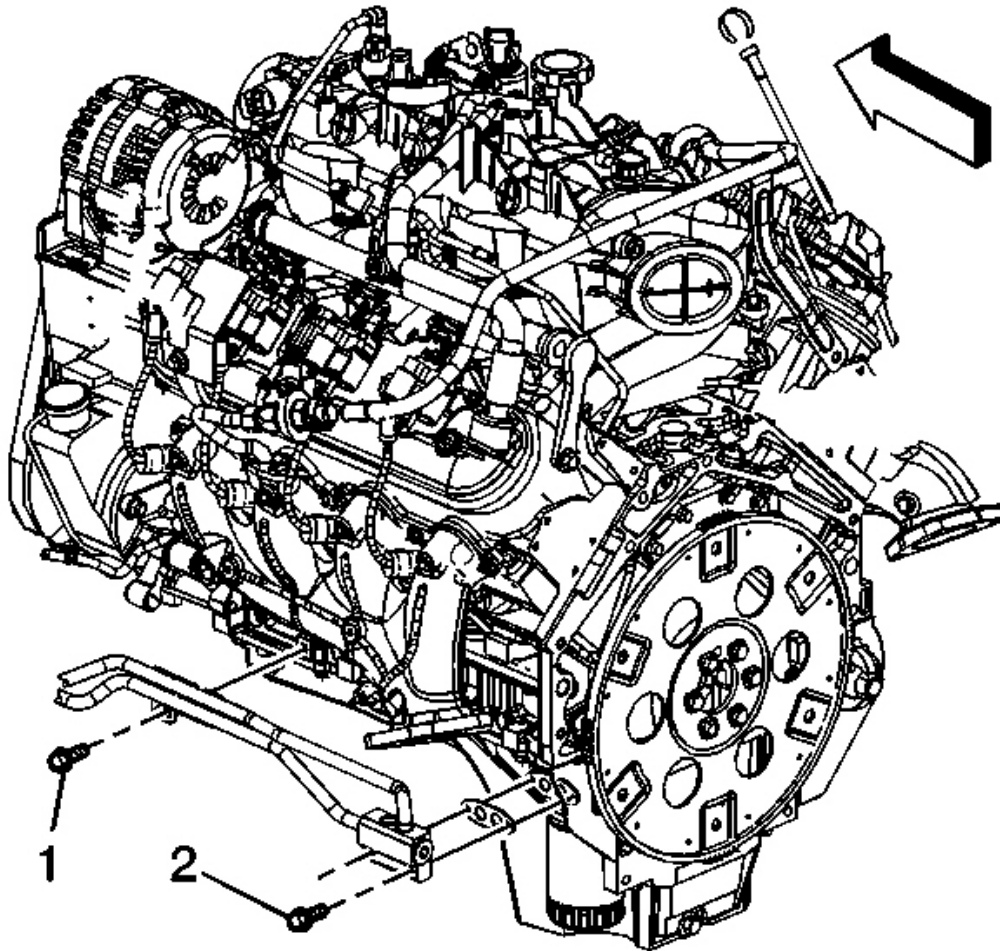

Fig. 44: Oil Cooler Hose Bracket Bolt & Adapter Bolts
Courtesy of GENERAL MOTORS CORP.

1. Install the engine oil cooler hose assembly and a new gasket.

NOTE: Refer to Fastener Notice in Cautions and Notices.

2. Install the engine oil cooler hose adapter bolts (2).

Tighten: Tighten the bolts to 12 N.m (106 lb in).

3. Install the engine oil cooler hose bracket bolt (1).

Tighten: Tighten the bolt to 25 N.m (18 lb ft).

www.4x4us.net

www.4x4us.net

4. Install the engine protection shield.
5. Install the engine shield bolts.

Tighten: Tighten the bolts to 20 N.m (15 lb ft).

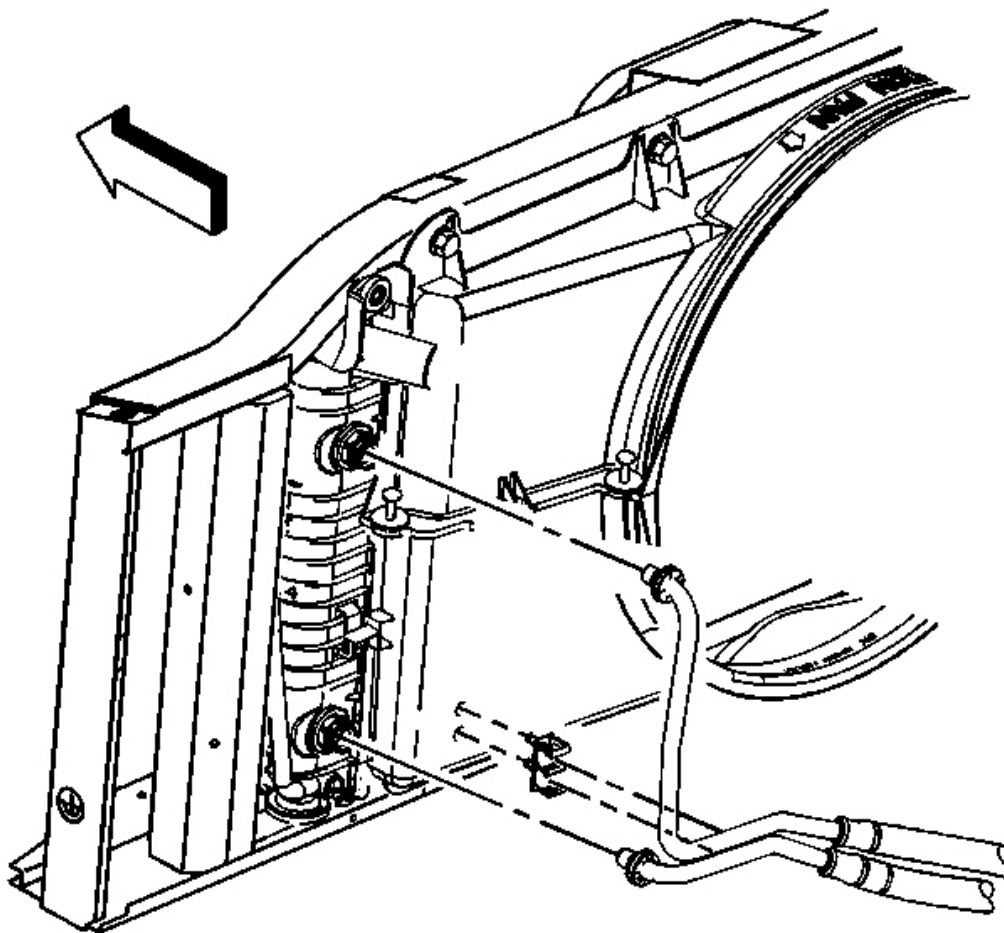

Fig. 45: Oil Cooler Hoses

Courtesy of GENERAL MOTORS CORP.

6. Install the engine oil cooler hoses to the fan shroud.
7. Install the engine oil cooler hoses to the radiator. Refer to Engine Oil Cooler Hose Quick Connect Fitting.

www.4x4us.net

www.4x4us.net

FAN REPLACEMENT
www.4x4us.net

www.4x4us.net

Tools Required

J 46406 Fan Clutch Remover and Installer. See **Special Tools and Equipment** .

Removal Procedure

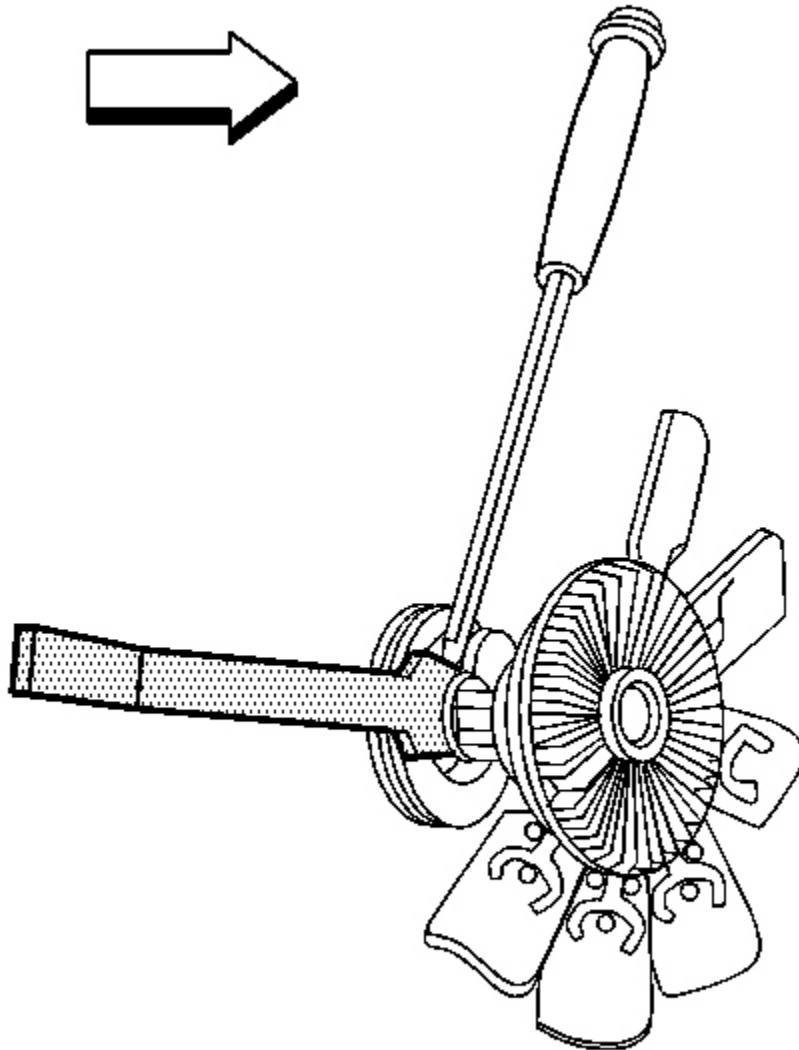

www.4x4us.net

www.4x4us.net

Fig. 46: Installing J 46406 To Fan Clutch
Courtesy of GENERAL MOTORS CORP.

1. Remove the fan shroud. Refer to **Fan Shroud Replacement** .
2. Install **J 46406** to the fan clutch. See **Special Tools and Equipment** .

www.4x4us.net

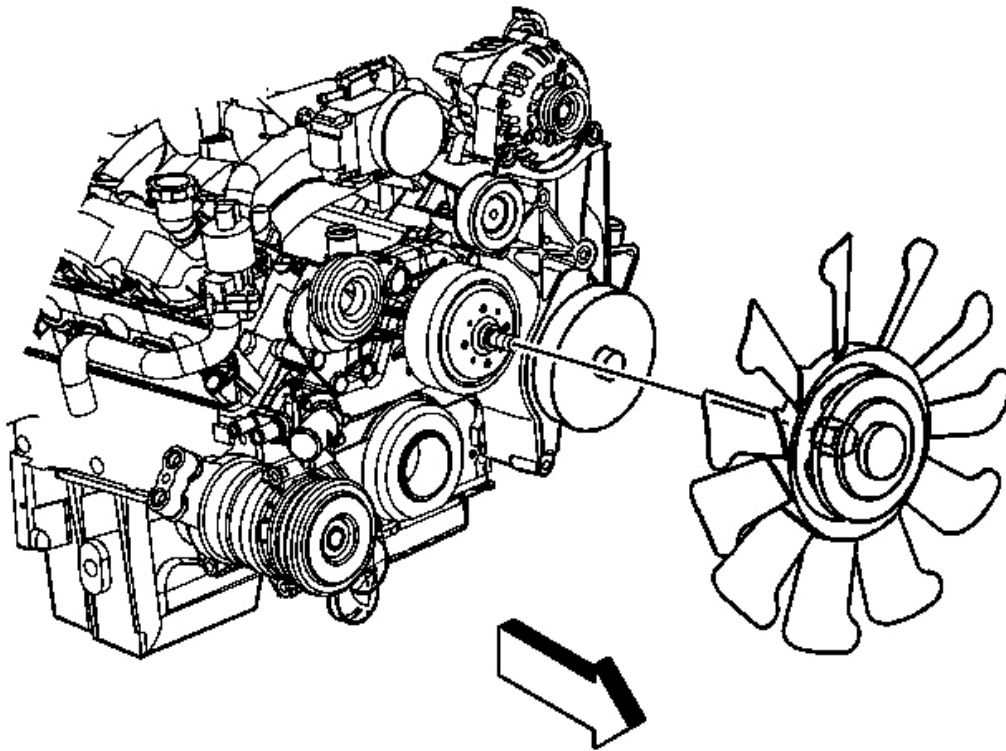

Fig. 47: View Of Fan Assembly
Courtesy of GENERAL MOTORS CORP.

3. Remove the fan hub nut from the water pump.

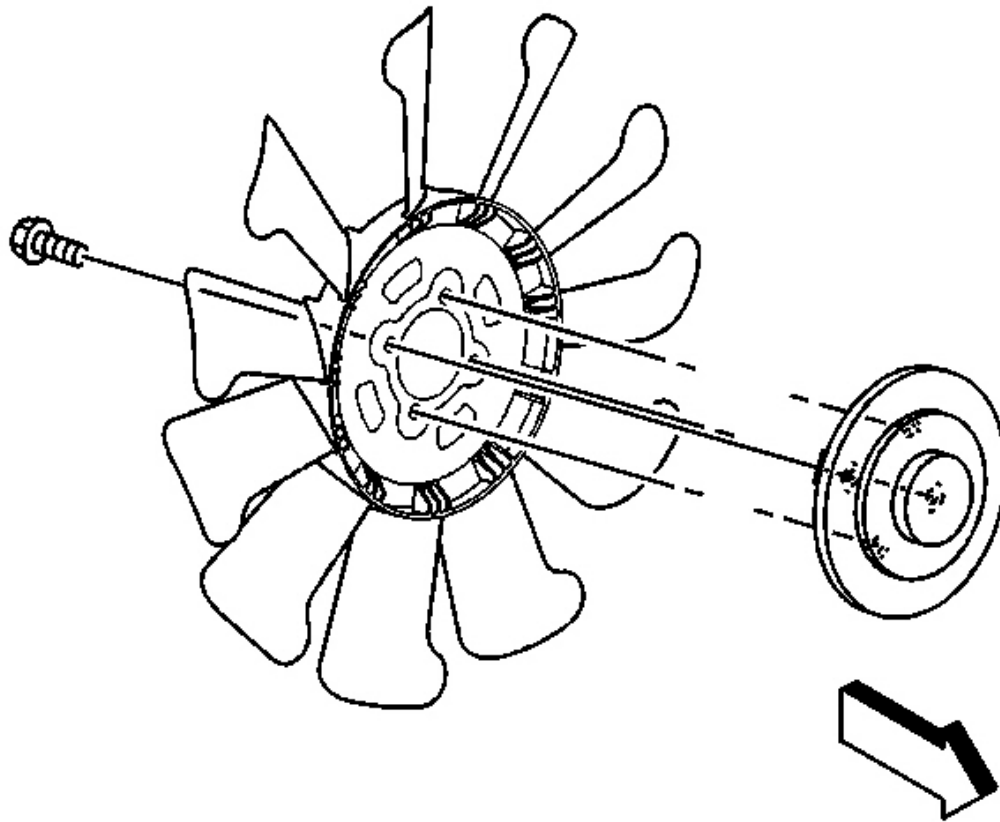

Fig. 48: Fan Clutch & Fan Blade
Courtesy of GENERAL MOTORS CORP.

4. Remove the bolts from the fan clutch.
5. Separate the fan clutch from the fan blade.

Installation Procedure

CAUTION: Do not use or attempt to repair a damaged cooling fan assembly. Replace damaged fans with new assemblies. An unbalanced cooling fan could fly apart causing personal injury and property damage.

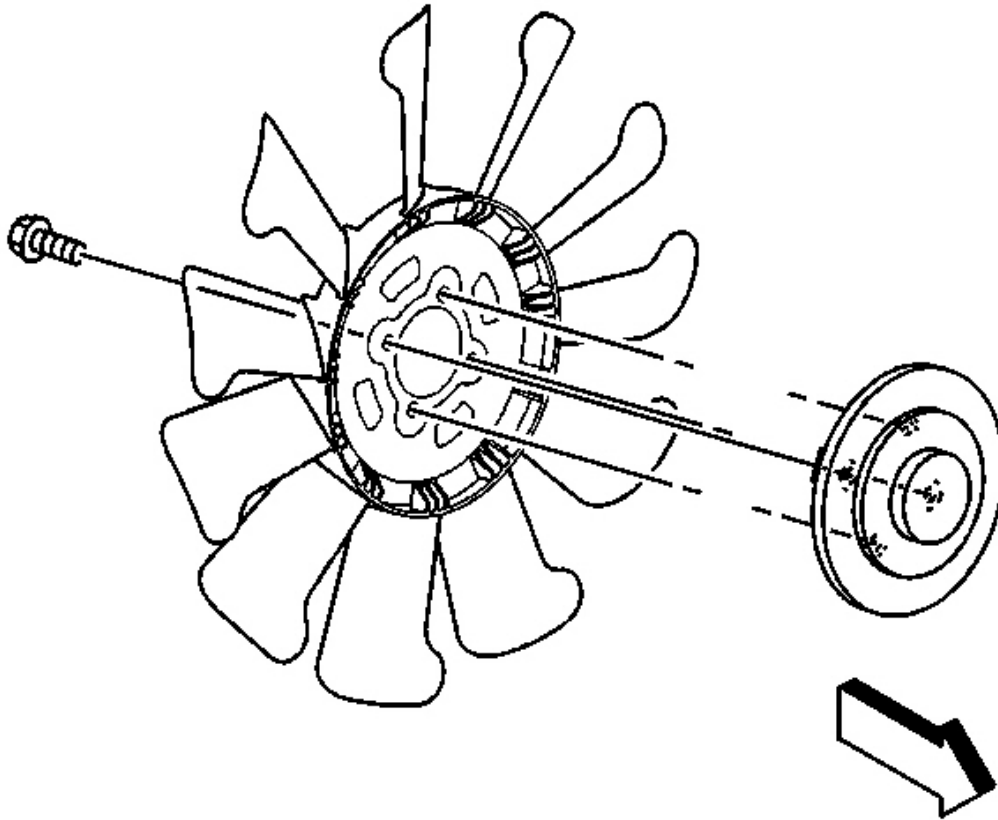

Fig. 49: Fan Clutch & Fan Blade
Courtesy of GENERAL MOTORS CORP.

1. Install the fan clutch to the fan blade.

NOTE: Refer to Fastener Notice in Cautions and Notices.

2. Install the bolts to the fan clutch.

Tighten: Tighten the bolts to 23 N.m (17 lb ft).

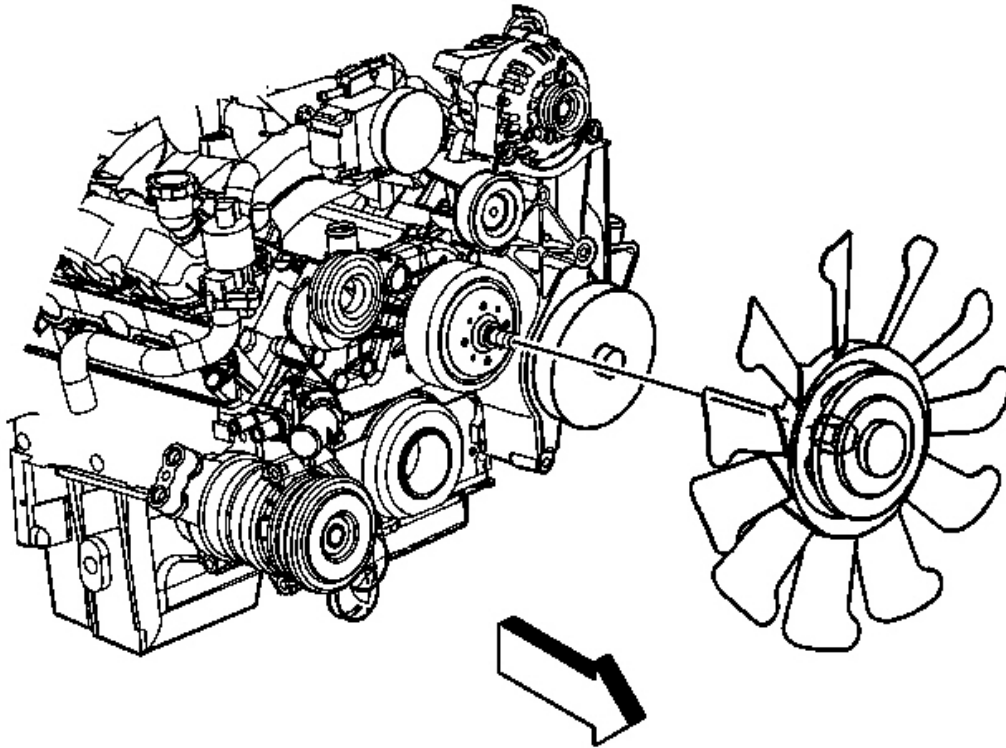

Fig. 50: View Of Fan Assembly
Courtesy of GENERAL MOTORS CORP.

3. Install the fan blade to the vehicle.

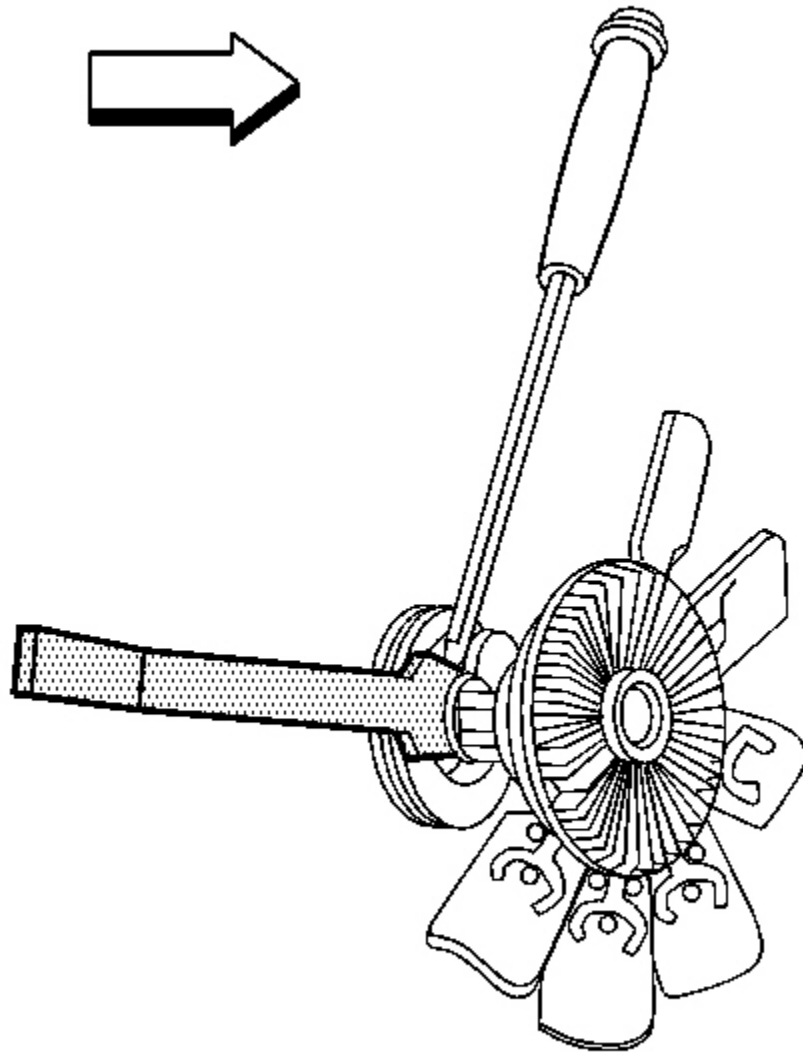

Fig. 51: Installing J 46406 To Fan Clutch
Courtesy of GENERAL MOTORS CORP.

4. Install **J 46406** to the fan clutch. See Special Tools and Equipment .

Tighten: Tighten the nut to 59 N.m (44 lb ft).

5. Install the fan shroud. Refer to Fan Shroud Replacement .

FAN CLUTCH REPLACEMENT

www.4x4us.net

www.4x4us.net

Tools Required

J 46406 Fan Clutch Remover and Installer. See Special Tools and Equipment .

Removal Procedure

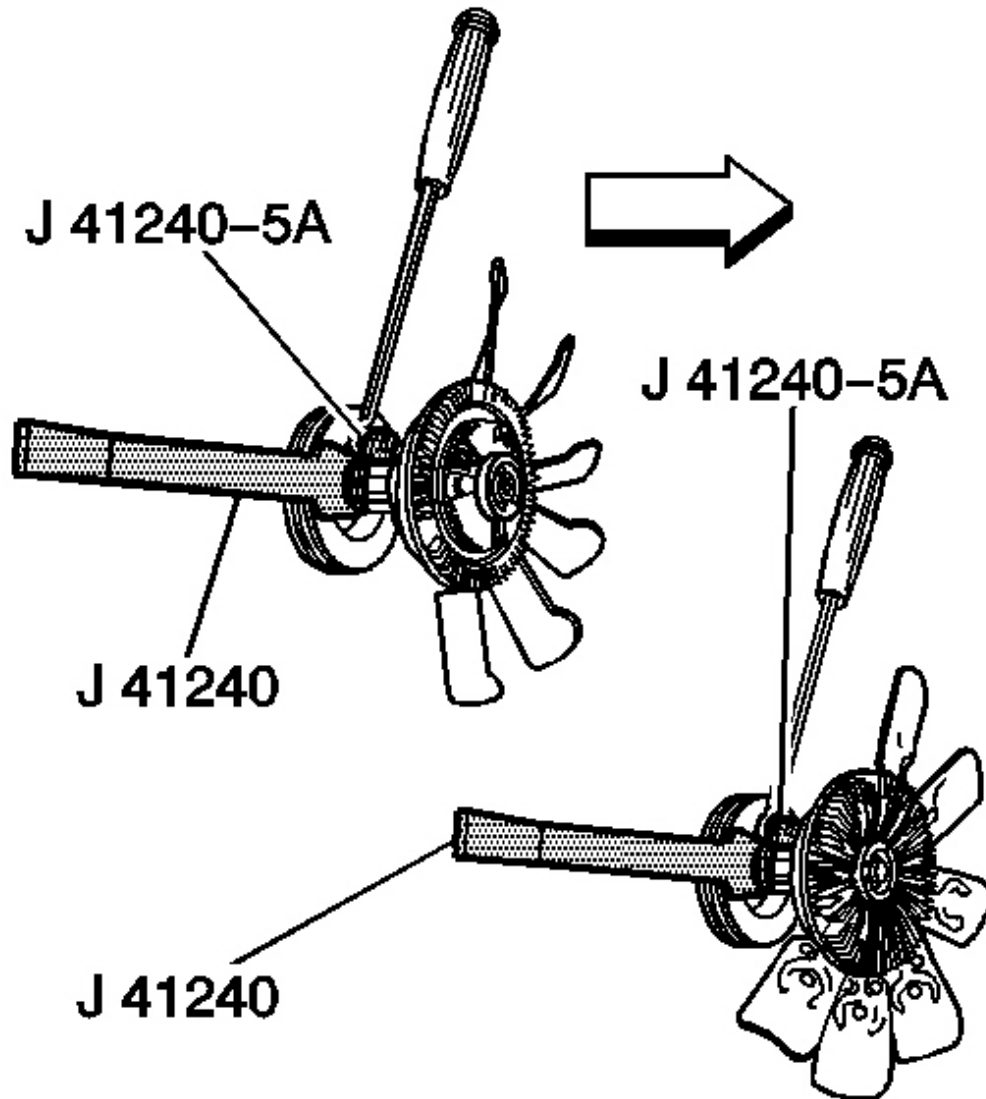

www.4x4us.net

www.4x4us.net

1. Remove the fan shroud. Refer to **Fan Shroud Replacement** .
2. Install the **J 46406** to the fan clutch. See **Special Tools and Equipment** .

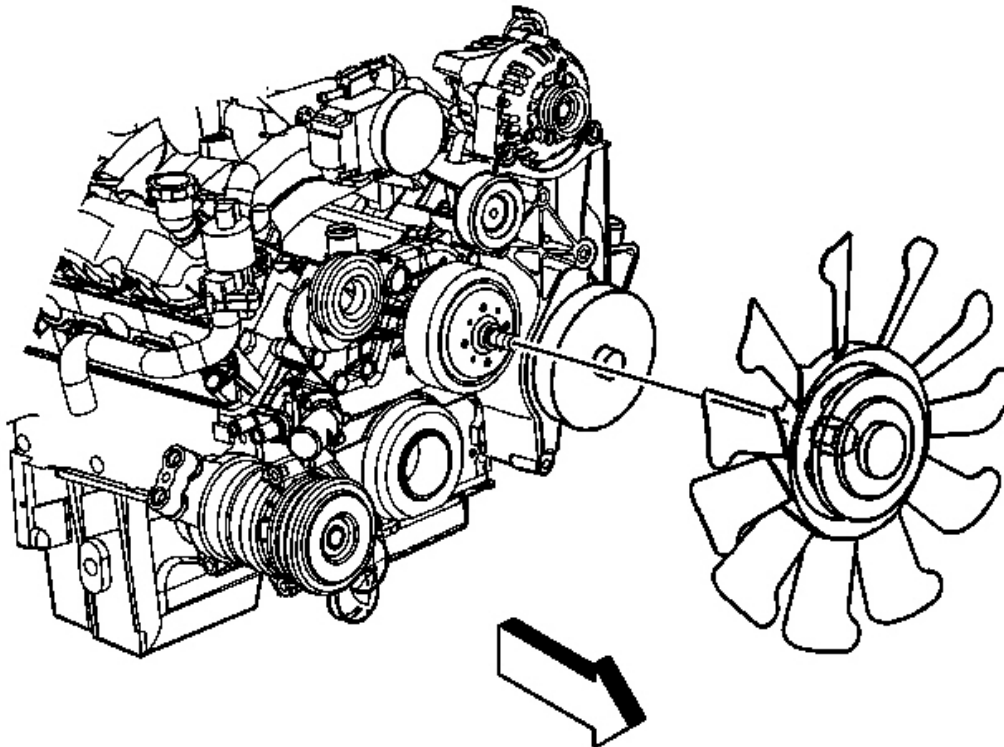

Fig. 53: View Of Fan Assembly
Courtesy of GENERAL MOTORS CORP.

3. Remove the fan hub nut from the water pump in a counterclockwise rotation.

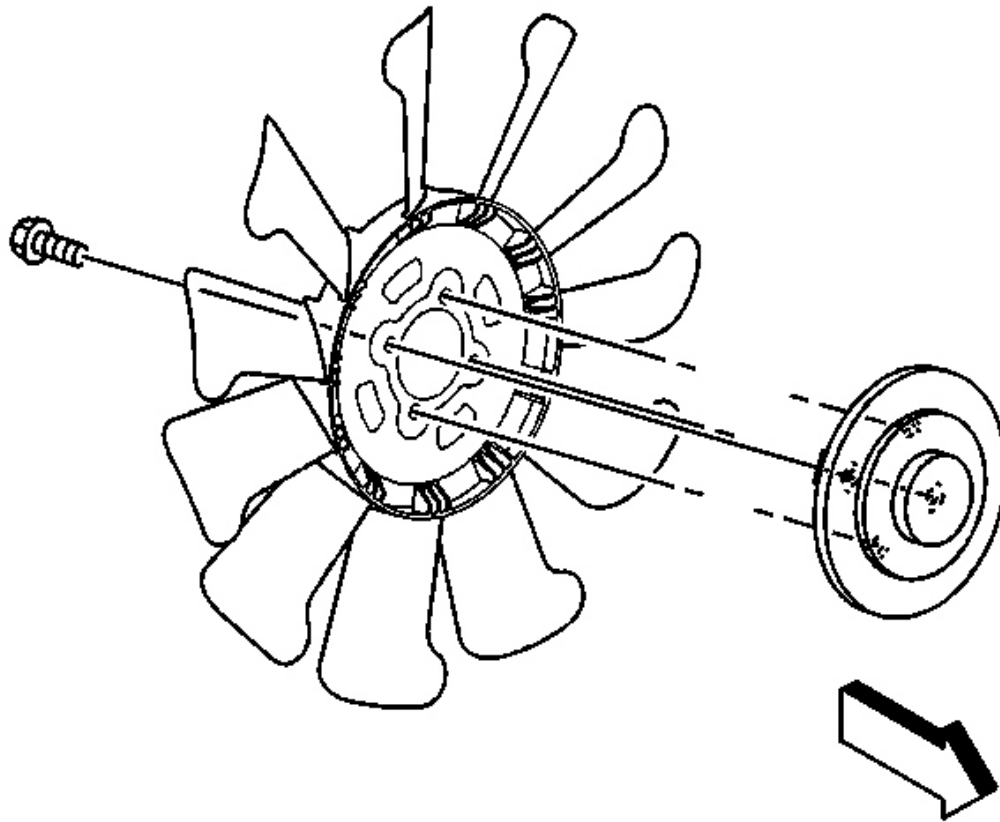

Fig. 54: Fan Clutch & Fan Blade
Courtesy of GENERAL MOTORS CORP.

4. Remove the bolts from the fan clutch.
5. Remove the fan clutch from the fan blade.

Installation Procedure

CAUTION: Do not use or attempt to repair a damaged cooling fan assembly. Replace damaged fans with new assemblies. An unbalanced cooling fan could fly apart causing personal injury and property damage.

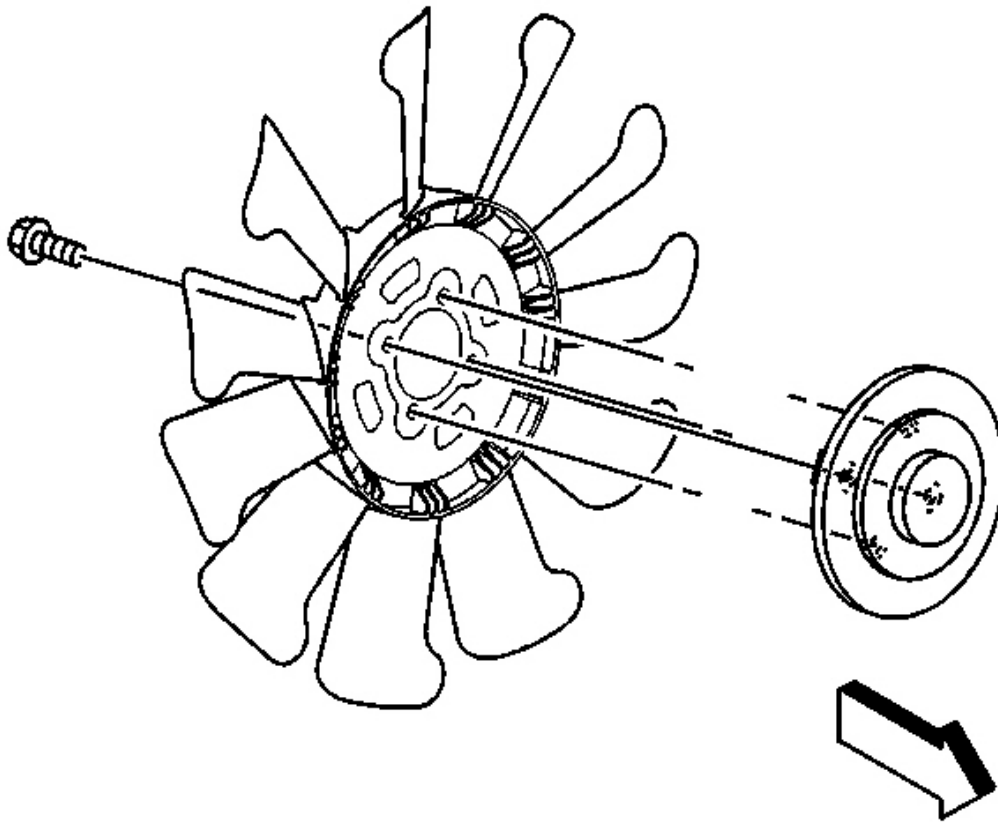

Fig. 55: Fan Clutch & Fan Blade
Courtesy of GENERAL MOTORS CORP.

1. Install the fan clutch to the fan blade.

NOTE: Refer to Fastener Notice in Cautions and Notices.

2. Install the bolts to the fan clutch.

Tighten: Tighten the bolts to 23 N.m (17 lb ft).

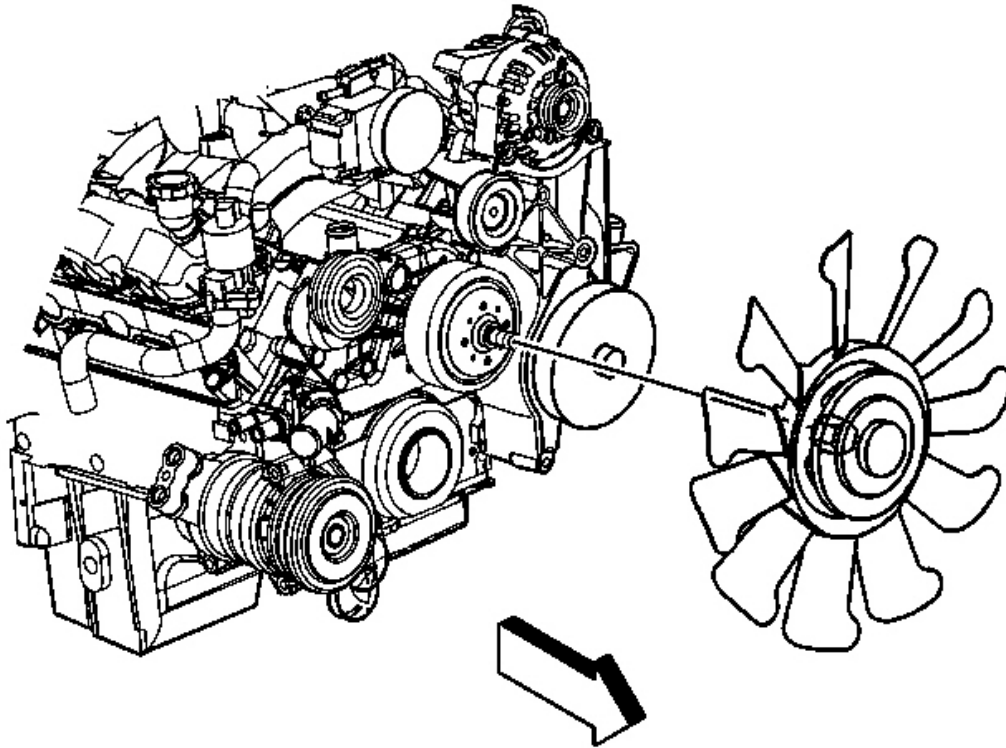

Fig. 56: View Of Fan Assembly
Courtesy of GENERAL MOTORS CORP.

3. Install the fan blade to the vehicle.

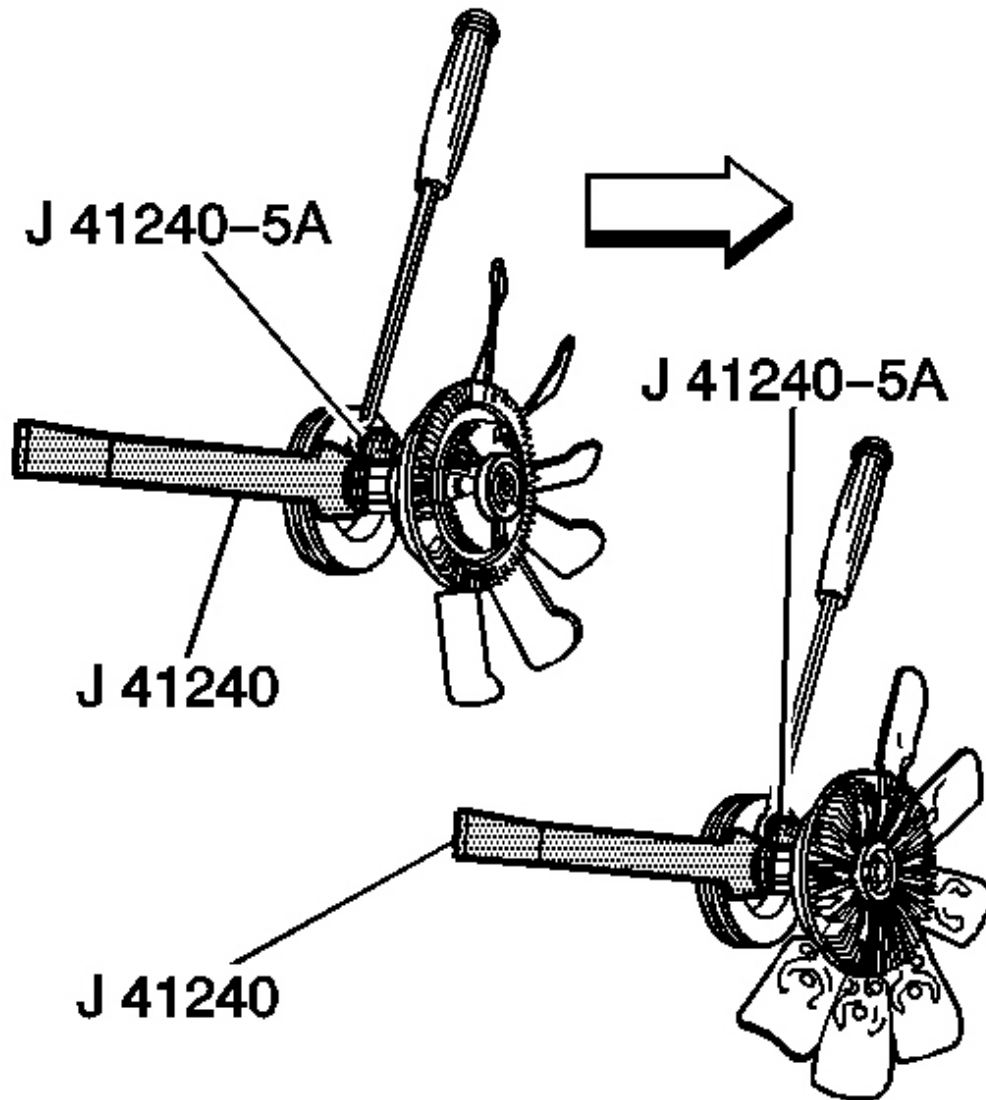

Fig. 57: Using Special Tools For Fan Clutch
Courtesy of GENERAL MOTORS CORP.

4. Install the **J 46406** to the fan clutch. See **Special Tools and Equipment** .

Tighten: Tighten the nut clockwise to 59 N.m (44 lb ft).
www.4x4us.net

5. Install the fan shroud. Refer to **Fan Shroud Replacement** .

THERMOSTAT HOUSING REPLACEMENT

www.4x4us.net

www.4x4us.net

Removal Procedure

IMPORTANT: The thermostat is not serviceable separately. The thermostat housing (water pump inlet) and thermostat must be replaced as an assembly.

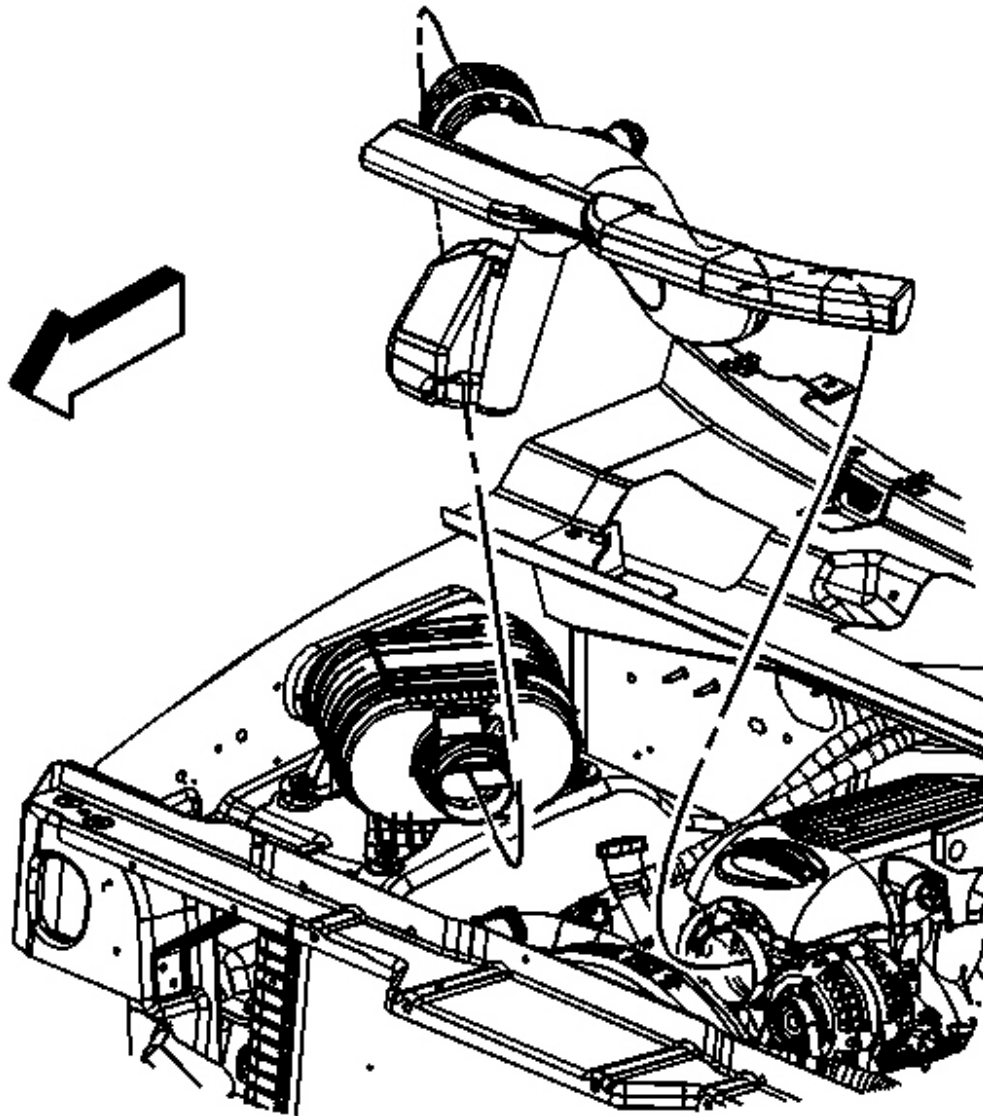

www.4x4us.net

www.4x4us.net

Fig. 58: Air Cleaner Outlet Duct

www.4x4us.net
Courtesy of GENERAL MOTORS CORP.

www.4x4us.net

1. Drain the cooling system/engine block. Refer to **Draining and Filling Cooling System** .
2. Loosen the air cleaner outlet duct clamps at the throttle body and at the Mass airflow (MAF) sensor.
3. Remove the air cleaner outlet duct.

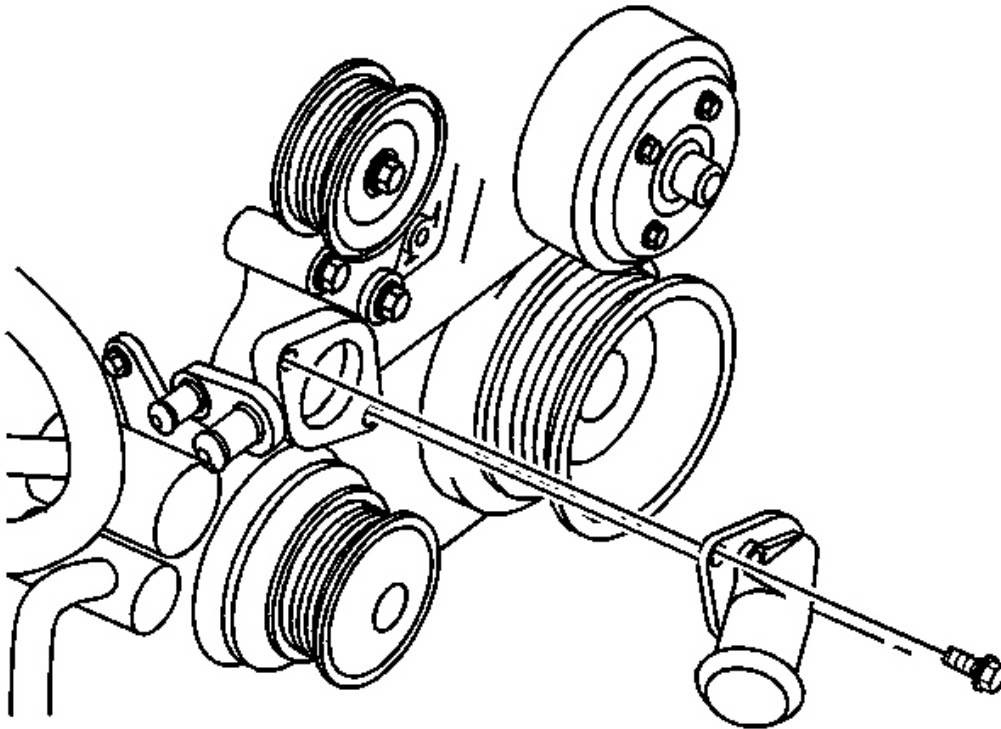

Fig. 59: Water Pump Inlet & Thermostat Housing

Courtesy of GENERAL MOTORS CORP.

4. Remove the radiator outlet hose.
5. Remove the thermostat housing bolts.
6. Remove the thermostat housing from the water pump.

Installation Procedure

www.4x4us.net

www.4x4us.net

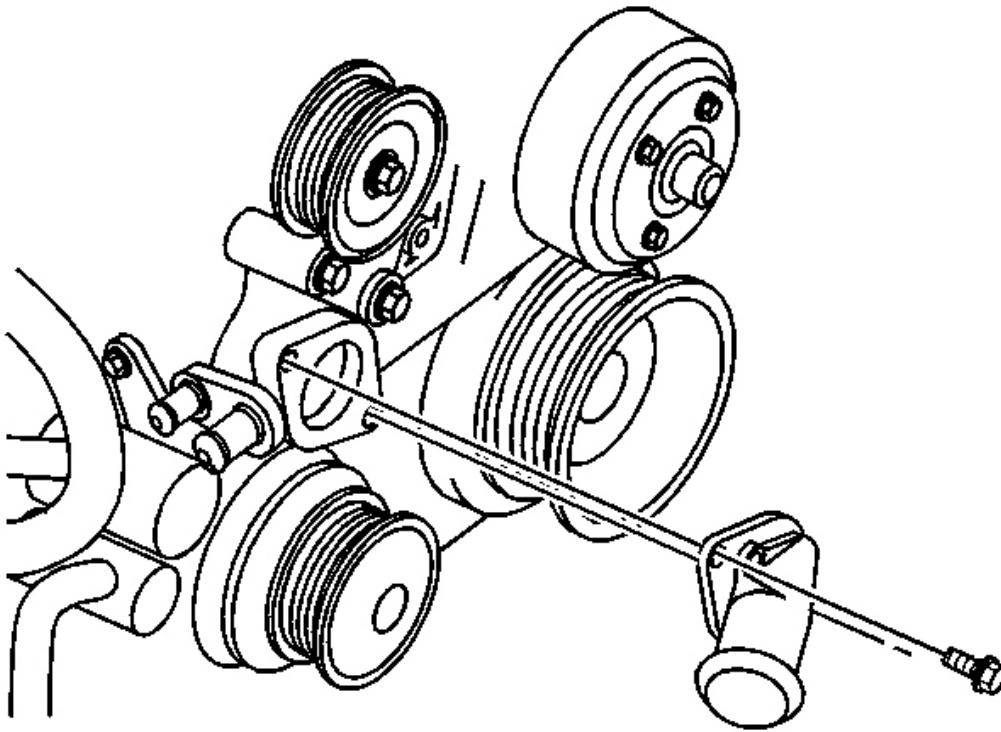

Fig. 60: Water Pump Inlet & Thermostat Housing
Courtesy of GENERAL MOTORS CORP.

NOTE: Refer to Fastener Notice in Cautions and Notices.

1. Install the thermostat housing to the water pump.
2. Install the thermostat housing bolts.

Tighten: Tighten the bolts to 15 N.m (11 lb ft).

3. Install the radiator outlet hose.

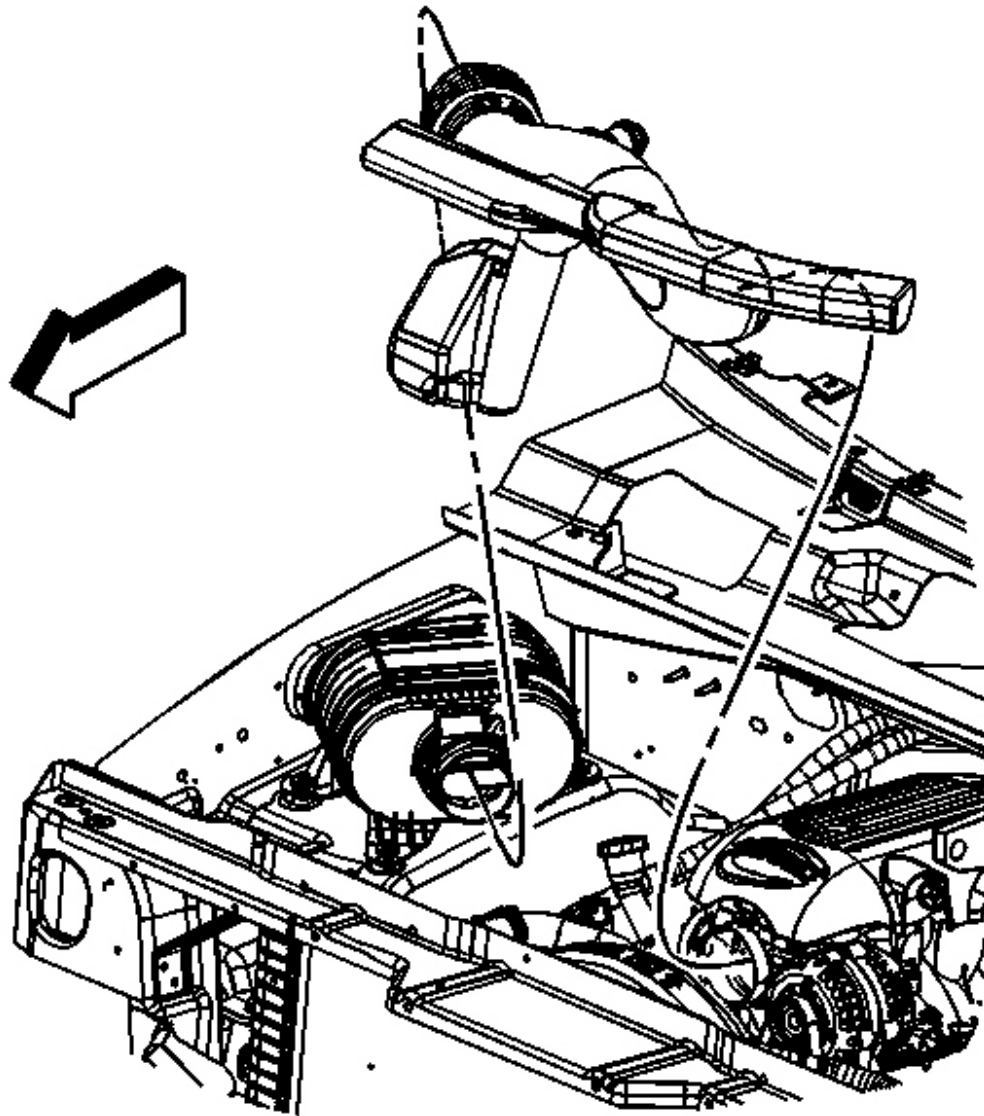

Fig. 61: Air Cleaner Outlet Duct
Courtesy of GENERAL MOTORS CORP.

4. Install the air cleaner outlet duct.
5. Install the air cleaner outlet duct clamps at the throttle body and at the Mass airflow (MAF) sensor.

Tighten: Tighten the air cleaner outlet duct clamp screws to 7 N.m (62 lb in).

6. Fill the cooling system. Refer to **Draining and Filling Cooling System**
www.4x4us.net

www.4x4us.net

COOLANT AIR BLEED PIPE ASSEMBLY REPLACEMENT

Removal Procedure

1. Drain the cooling system. Refer to **Draining and Filling Cooling System** .
2. Remove the generator. Refer to **Generator Replacement** in Engine Electrical.

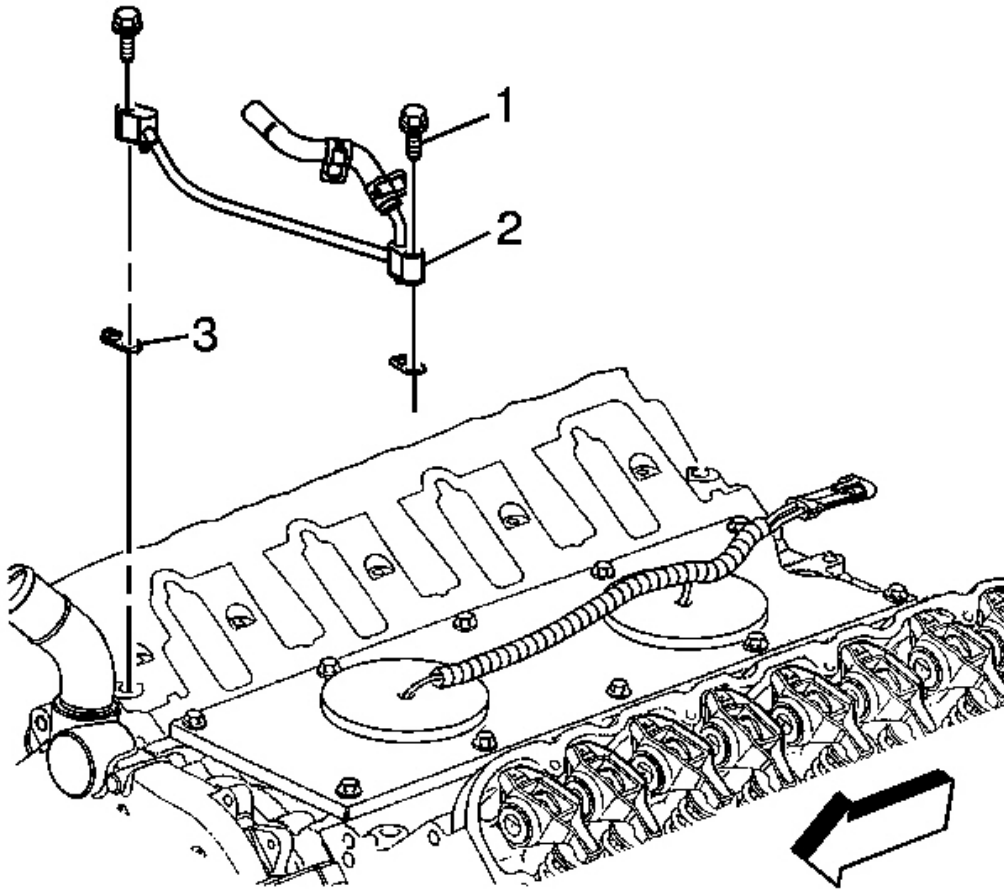

Fig. 62: Coolant Air Bleed Pipe & Gaskets
Courtesy of GENERAL MOTORS CORP.

3. Remove the coolant air bleed pipe bolts (1).
4. Remove the coolant air bleed pipe (2) with gaskets (3).

www.4x4us.net

www.4x4us.net

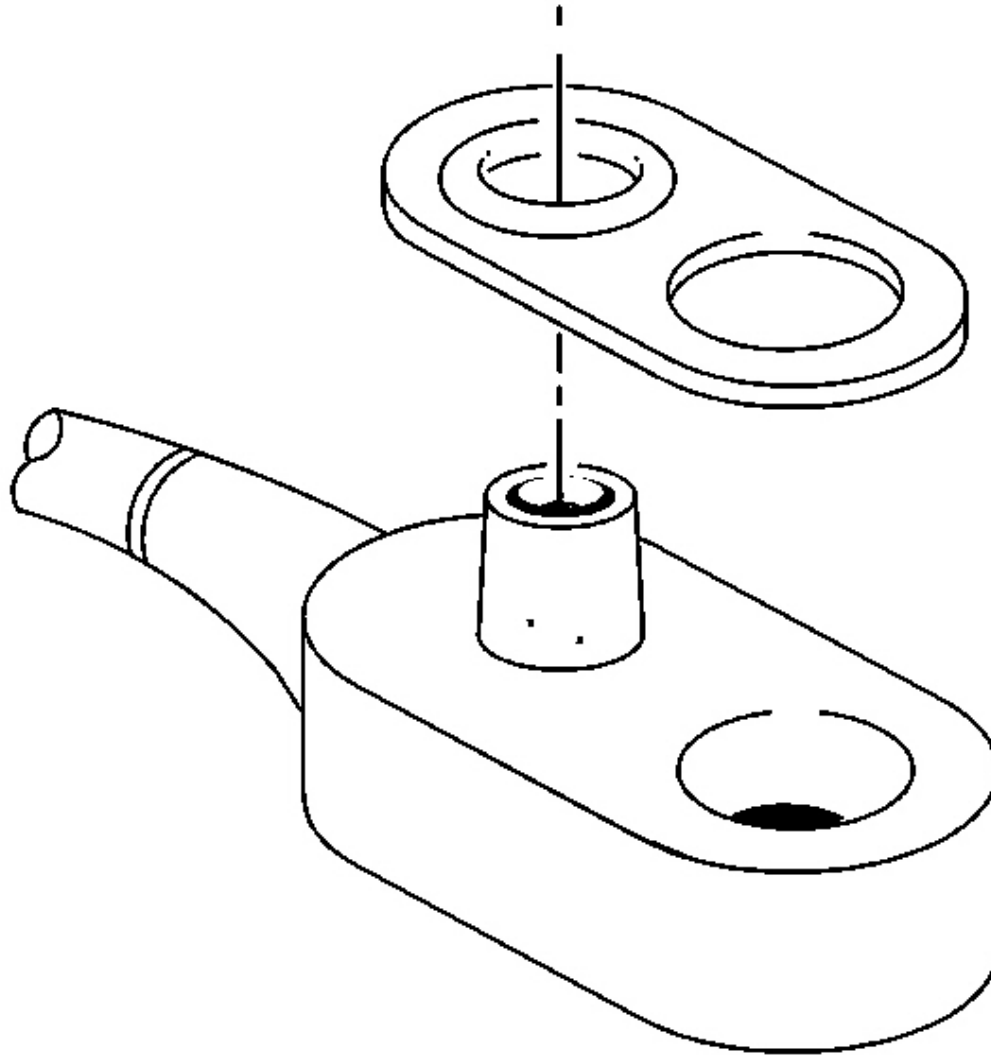

Fig. 63: Pipe & Cover Gasket
Courtesy of GENERAL MOTORS CORP.

5. Remove the gaskets from the coolant air bleed pipe and covers.
6. Discard the gaskets.

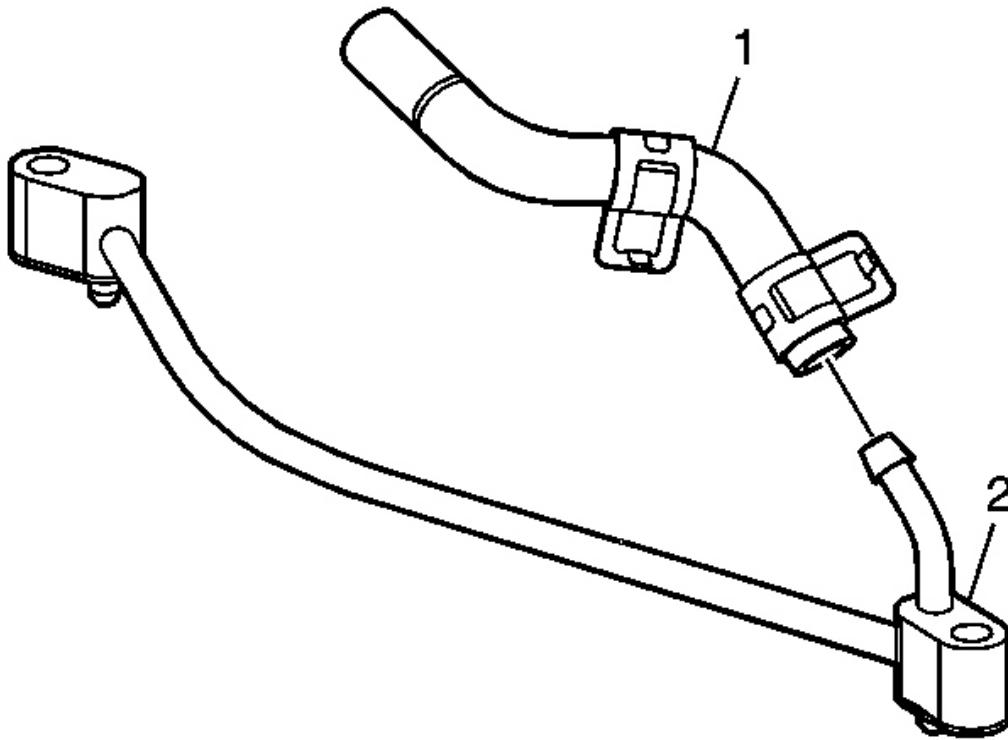

Fig. 64: Coolant Air Bleed Hose & Pipe
Courtesy of GENERAL MOTORS CORP.

7. Remove the coolant air bleed hose (1) from the pipe (2).

Installation Procedure

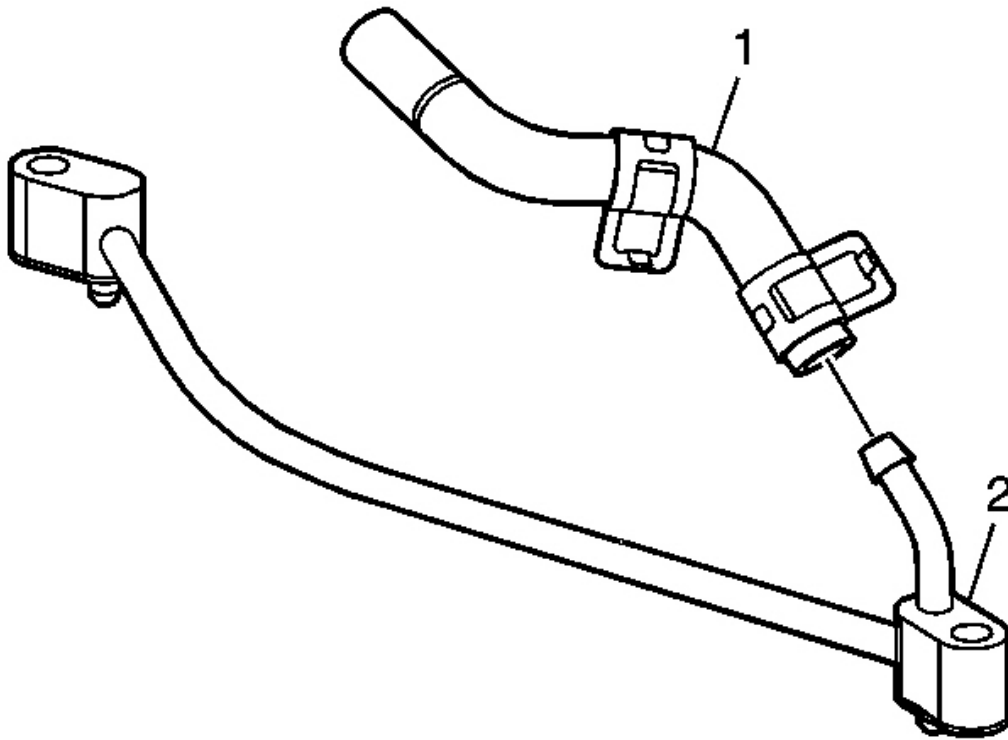

Fig. 65: Coolant Air Bleed Hose & Pipe
Courtesy of GENERAL MOTORS CORP.

1. Install the coolant air bleed hose (1) onto the pipe (2).

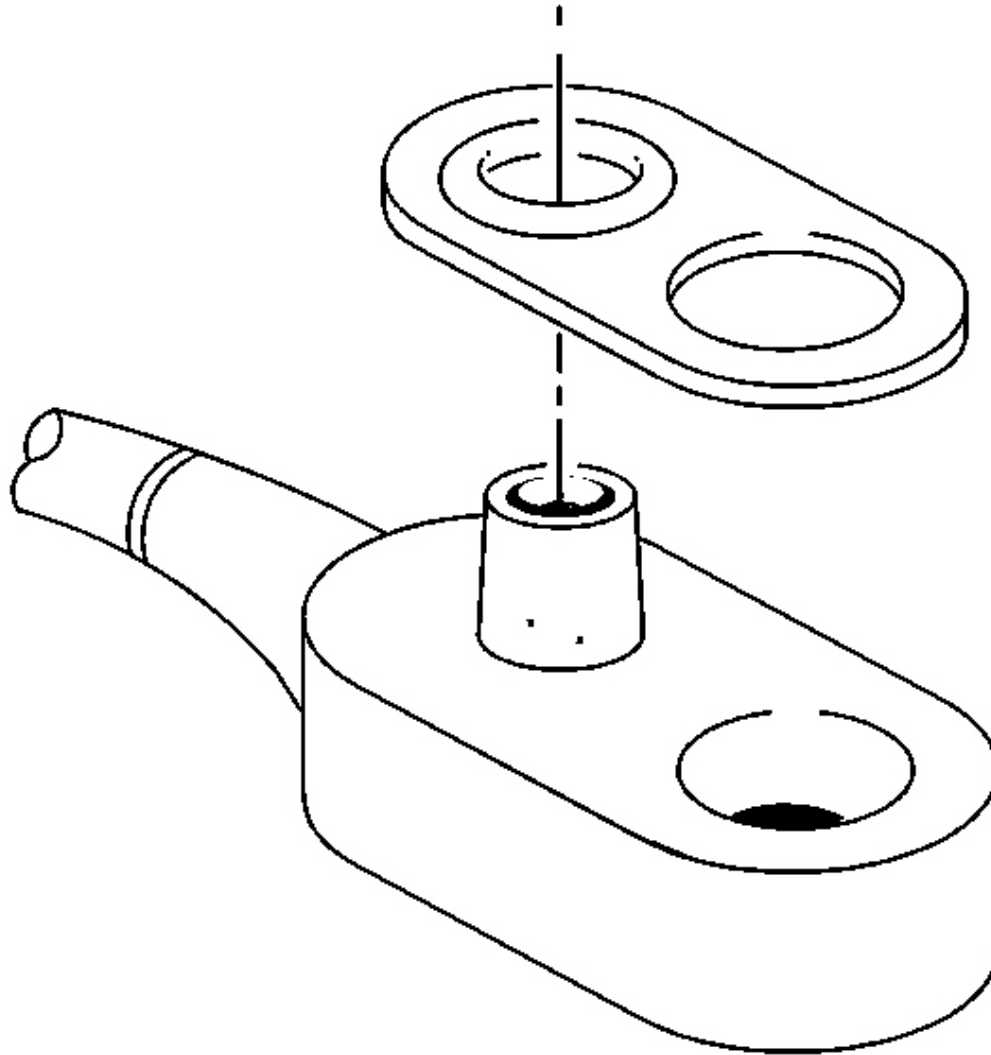

Fig. 66: Pipe & Cover Gasket
Courtesy of GENERAL MOTORS CORP.

IMPORTANT: Install the gaskets properly onto the pipe and covers. Position the O-ring seal onto the nipple portion of the pipe.

2. Install the gaskets onto the coolant air bleed pipe and covers.

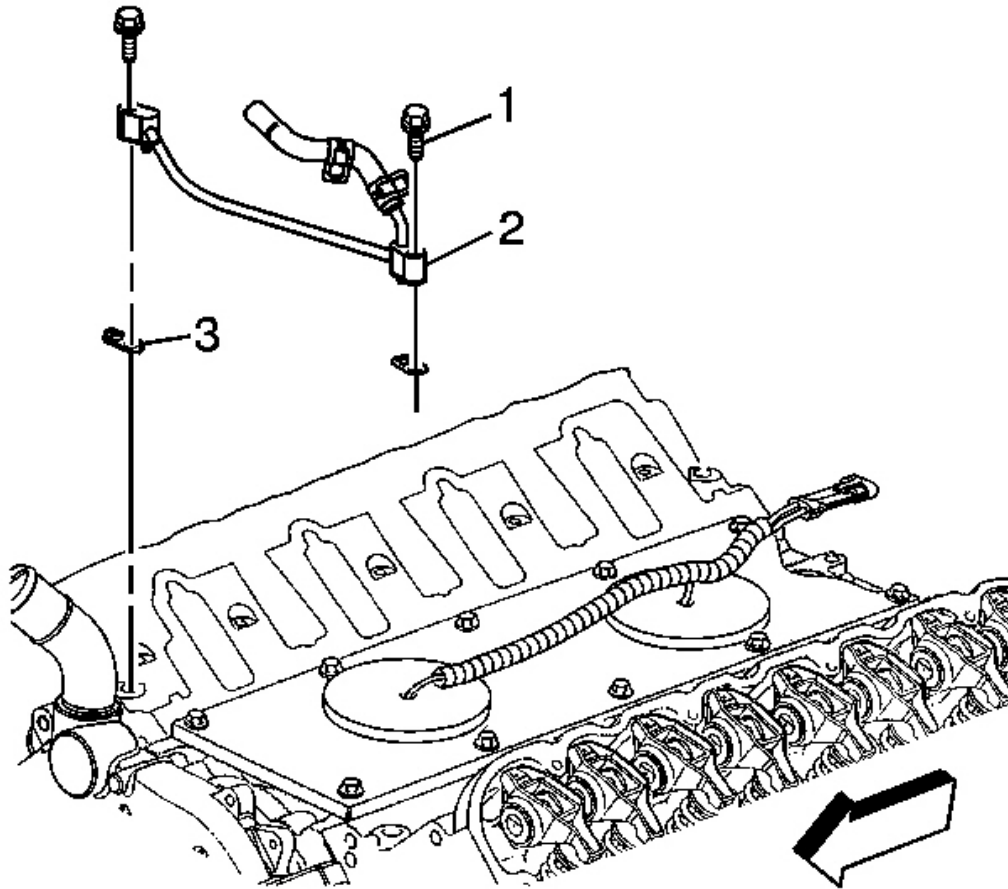

Fig. 67: Coolant Air Bleed Pipe & Gaskets
Courtesy of GENERAL MOTORS CORP.

NOTE: Refer to Fastener Notice in Cautions and Notices.

3. Install the coolant air bleed pipe (2) and gaskets (3) onto the cylinder heads.
4. Install the coolant air bleed pipe bolts (1).

Tighten: Tighten the coolant air bleed pipe bolts to 12 N.m (106 lb in).

5. Install the generator. Refer to Generator Replacement in Engine Electrical.
6. Fill the cooling system. Refer to Draining and Filling Cooling System.

1. Drain the cooling system. Refer to Draining and Filling Cooling System .

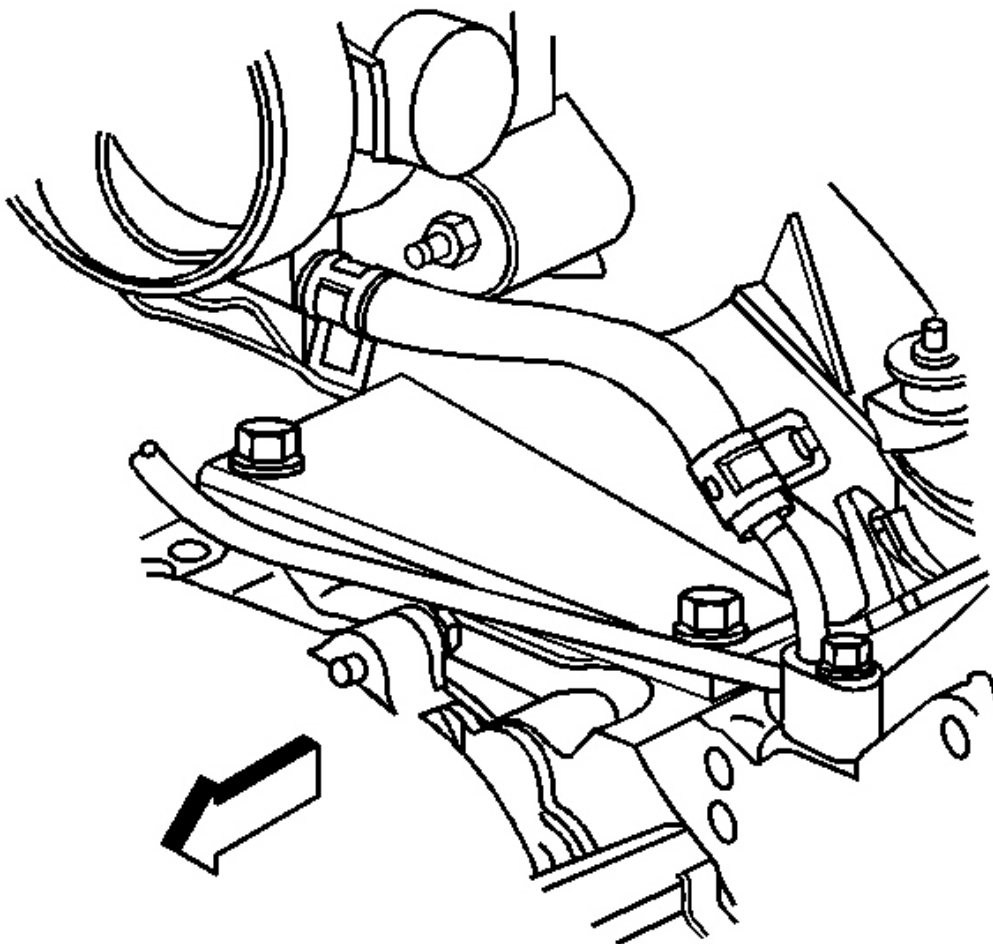

Fig. 68: Coolant Air Bleed Hose
Courtesy of GENERAL MOTORS CORP.

2. Remove the engine sight shield. Refer to Engine Sight Shield Replacement (6.0L (LQ4)) in Engine Mechanical - 4.8L, 5.3L and 6.0L.
3. Remove the air cleaner resonator outlet duct. Refer to Air Cleaner Resonator Outlet Duct Replacement in Engine Controls - 4.8L, 5.3L and 6.0L.
4. Reposition the coolant air bleed hose clamp at the throttle body.
5. Remove the coolant air bleed hose from the throttle body.

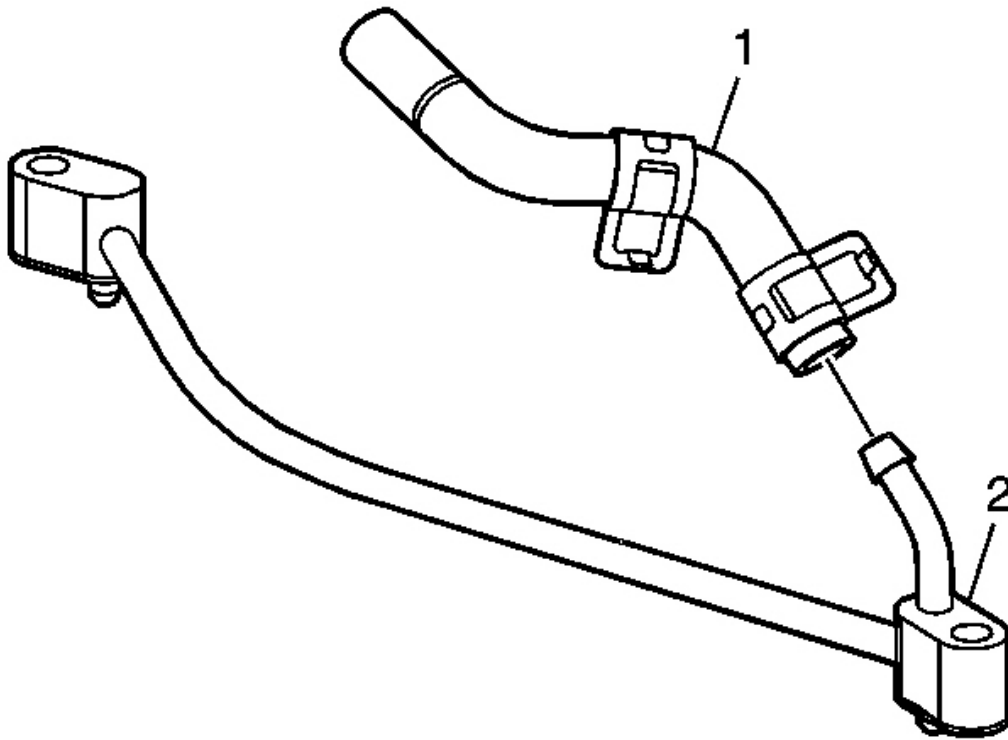

Fig. 69: Coolant Air Bleed Hose & Pipe
Courtesy of GENERAL MOTORS CORP.

6. Reposition the hose clamp at the pipe.
7. Remove the coolant air bleed hose (1) from the pipe (2).
8. Remove the coolant air bleed hose from the vehicle.

Installation Procedure

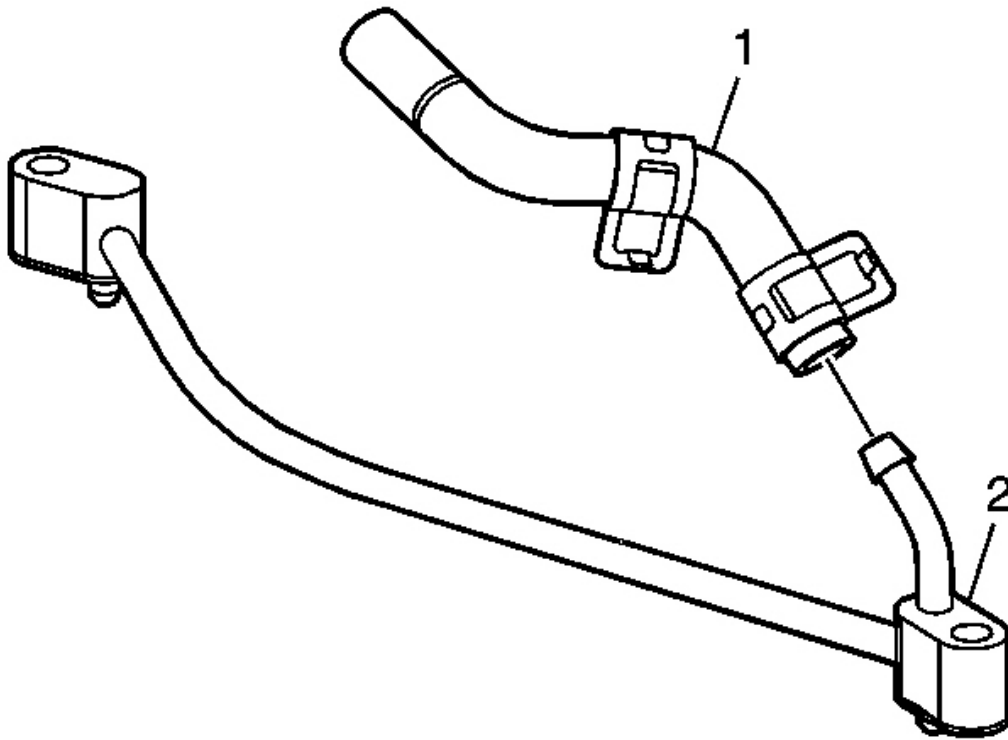

Fig. 70: Coolant Air Bleed Hose & Pipe
Courtesy of GENERAL MOTORS CORP.

1. Install the coolant air bleed hose (1) to the pipe (2).
2. Position the hose clamp at the pipe.

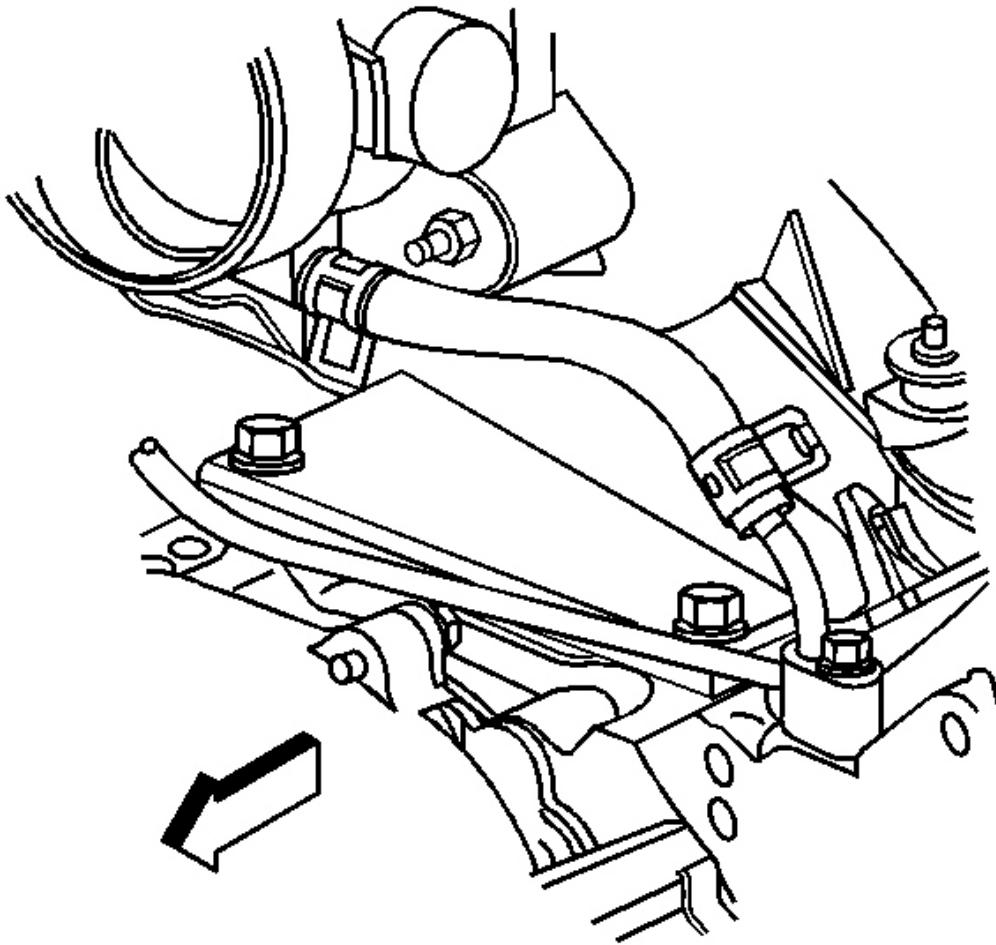

Fig. 71: Coolant Air Bleed Hose
Courtesy of GENERAL MOTORS CORP.

3. Install the coolant air bleed hose to the throttle body.
4. Position the coolant air bleed hose clamp at the throttle body.
5. Install the air cleaner resonator outlet duct. Refer to **Air Cleaner Resonator Outlet Duct Replacement** in Engine Controls - 4.8L, 5.3L and 6.0L.
6. Install the engine sight shield. Refer to **Engine Sight Shield Replacement (6.0L (LQ4))** in Engine Mechanical - 4.8L, 5.3L and 6.0L.
7. Add engine coolant, if necessary.

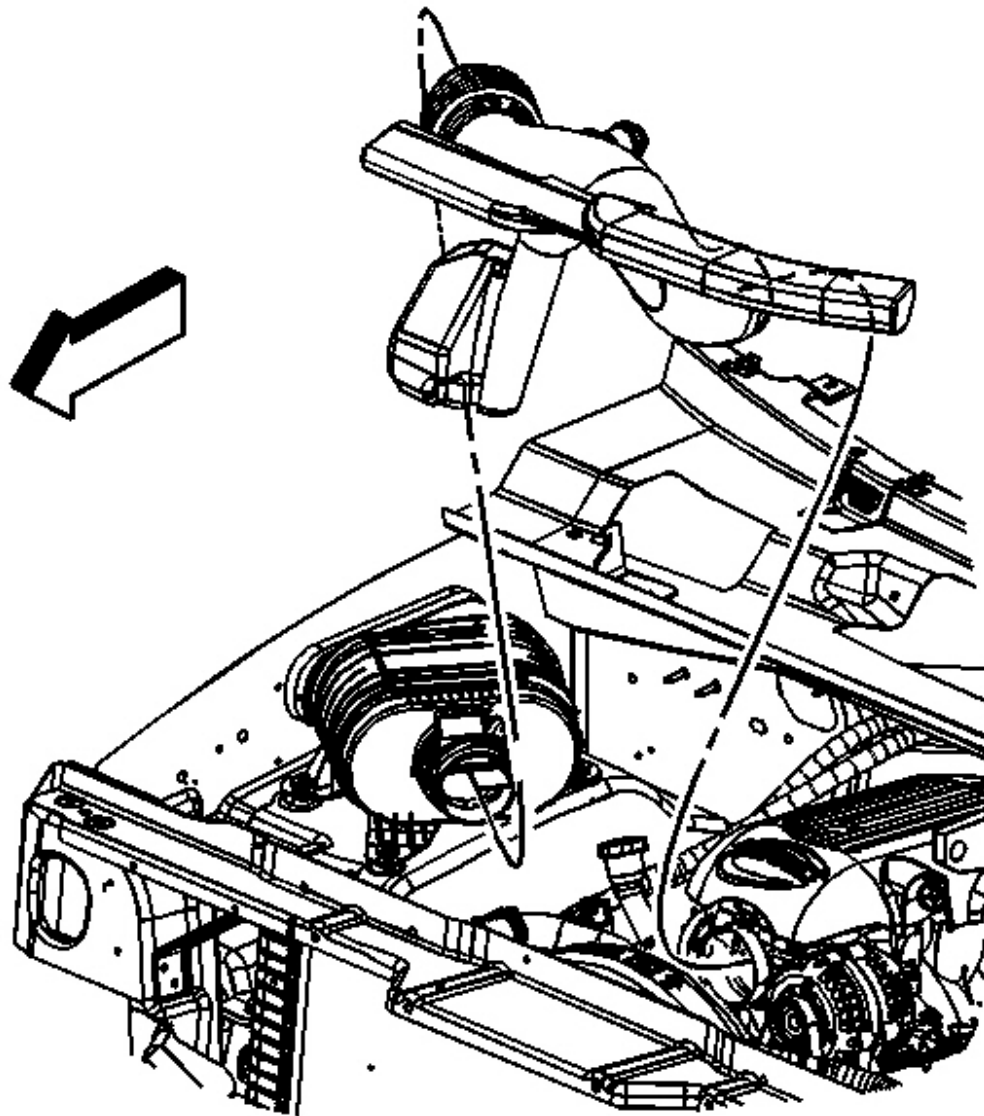

Fig. 72: Air Cleaner Outlet Duct
Courtesy of GENERAL MOTORS CORP.

1. Drain the cooling system. Refer to **Draining and Filling Cooling System** . www.4x4us.net
2. Loosen the air cleaner outlet duct clamps at the following locations:

- Mass airflow/intake air temperature (MAF/IAT) sensor

3. Remove the radiator inlet hose clip from the outlet duct.
4. Remove the air cleaner outlet duct.

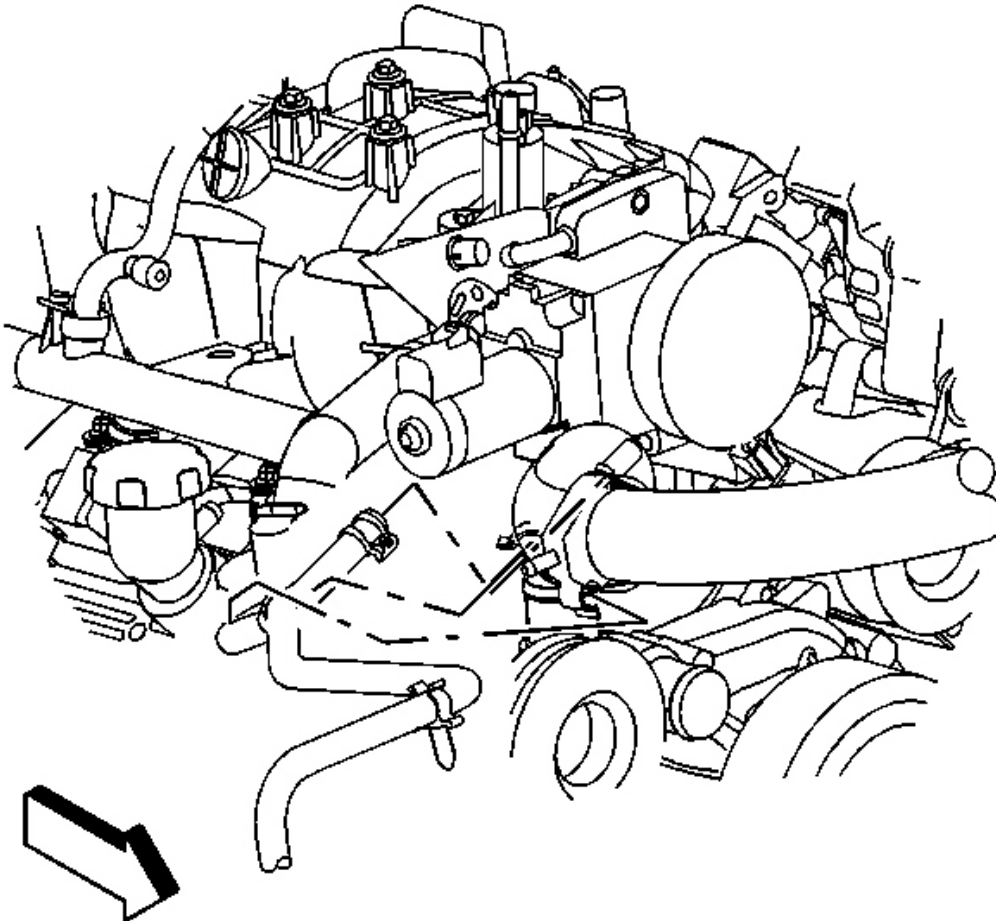

Fig. 73: Vent Inlet Hose At Throttle Body
Courtesy of GENERAL MOTORS CORP.

5. Remove the radiator vent inlet hose from the radiator hose clips.

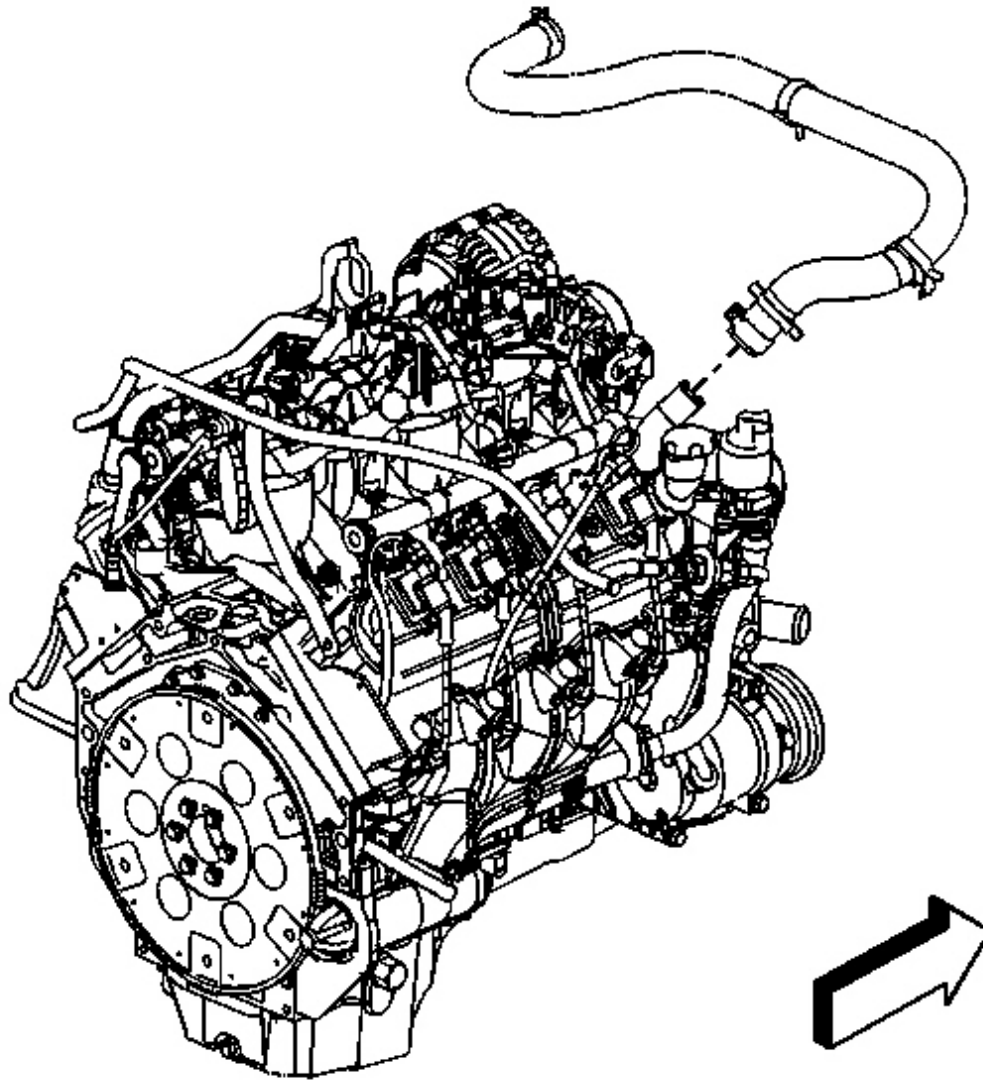

Fig. 74: Inlet Hose & Water Pump (4.8, 5.3, & 6.0L)
Courtesy of GENERAL MOTORS CORP.

6. Reposition the inlet hose clamp at the water pump.
7. Remove the inlet hose from the water pump.
8. Remove the fan blade. Refer to **Fan Replacement** .
9. Remove the accessory drive belt. Refer to **Drive Belt Replacement - Accessory** in Engine Mechanical - 6.0L (LQ4).

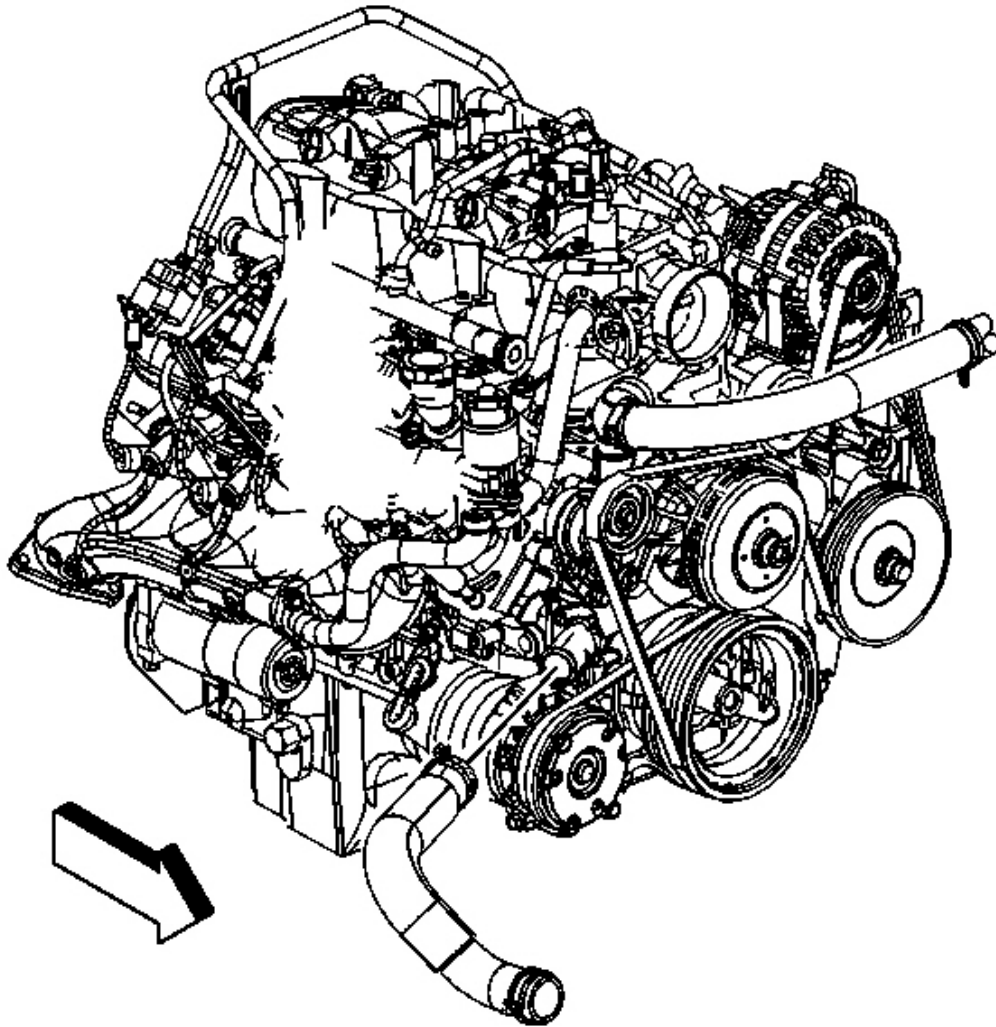

Fig. 75: Outlet Hose & Water Pump (4.8, 5.3, & 6.0L)
Courtesy of GENERAL MOTORS CORP.

10. Reposition the outlet hose clamp at the water pump.
11. Remove the outlet hose from the water pump.

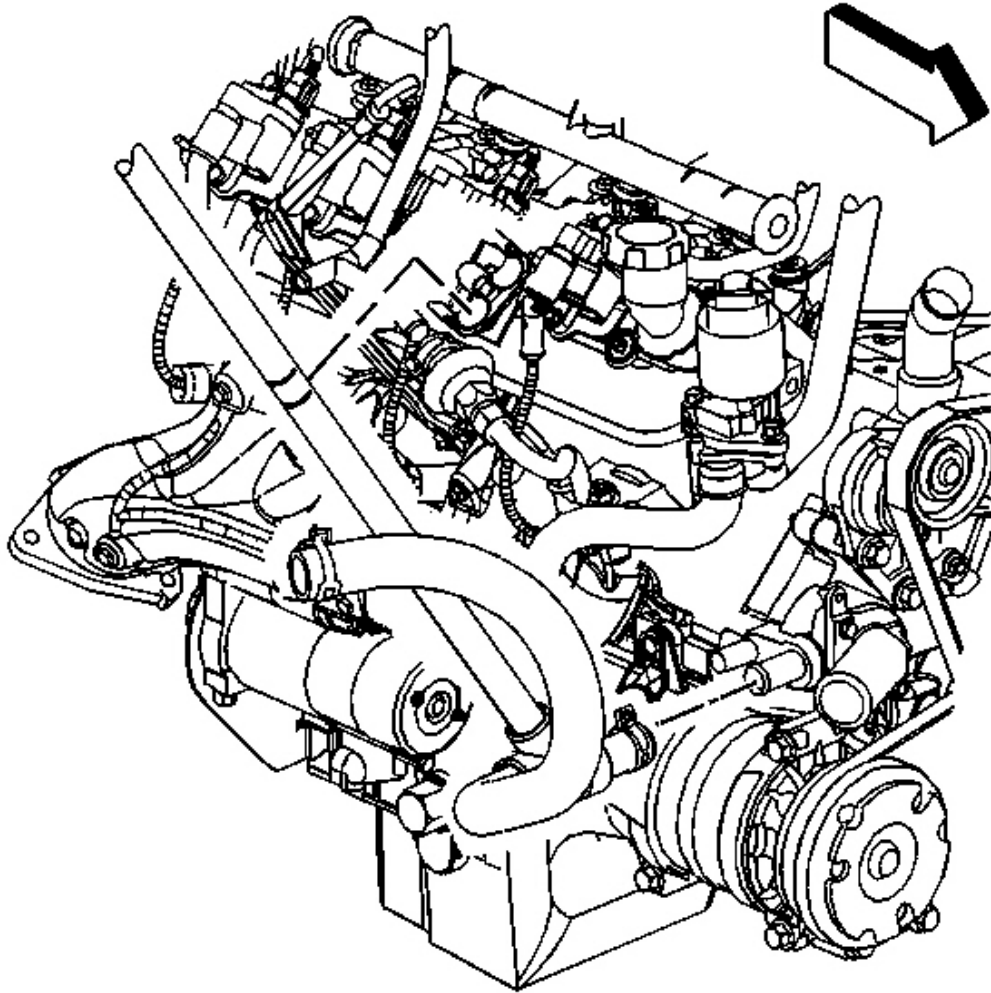

Fig. 76: Surge Tank Outlet Hose
Courtesy of GENERAL MOTORS CORP.

12. Reposition the surge tank outlet hose clamp at the water pump.
13. Remove the surge tank outlet hose from the water pump.

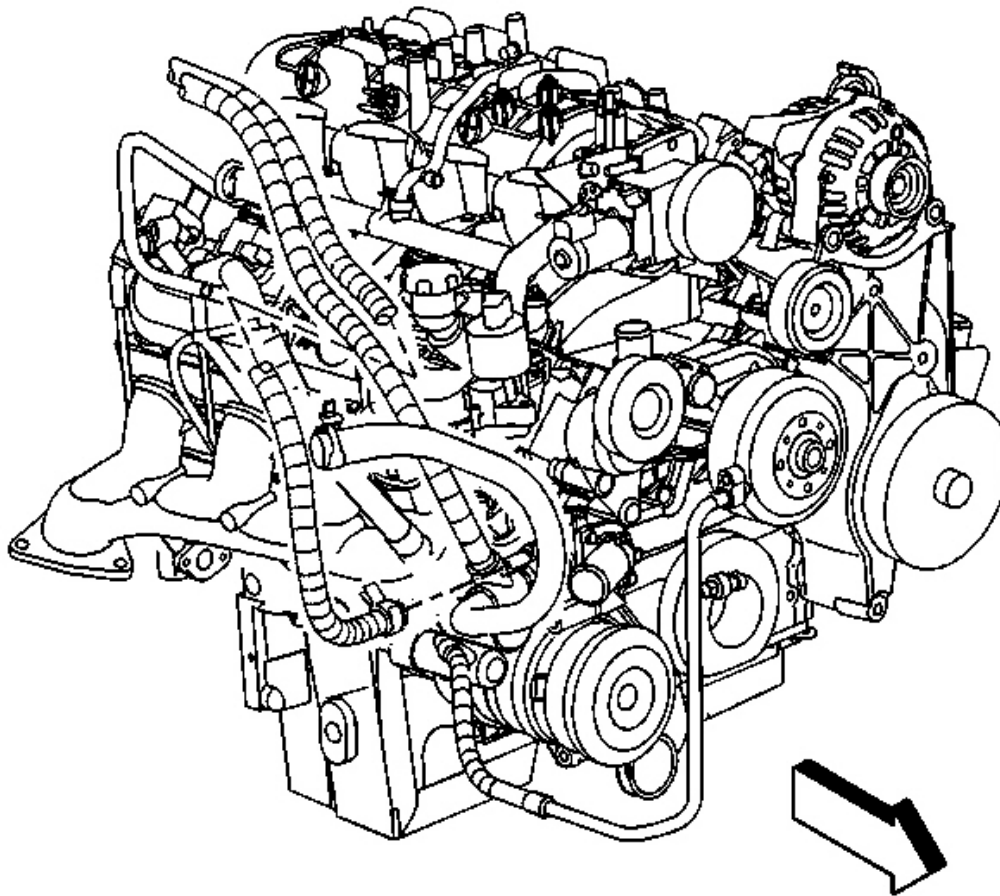

Fig. 77: Heater Inlet Hose
Courtesy of GENERAL MOTORS CORP.

14. Reposition the heater inlet hose clamp at the water pump.
15. Remove the heater inlet hose from the water pump.

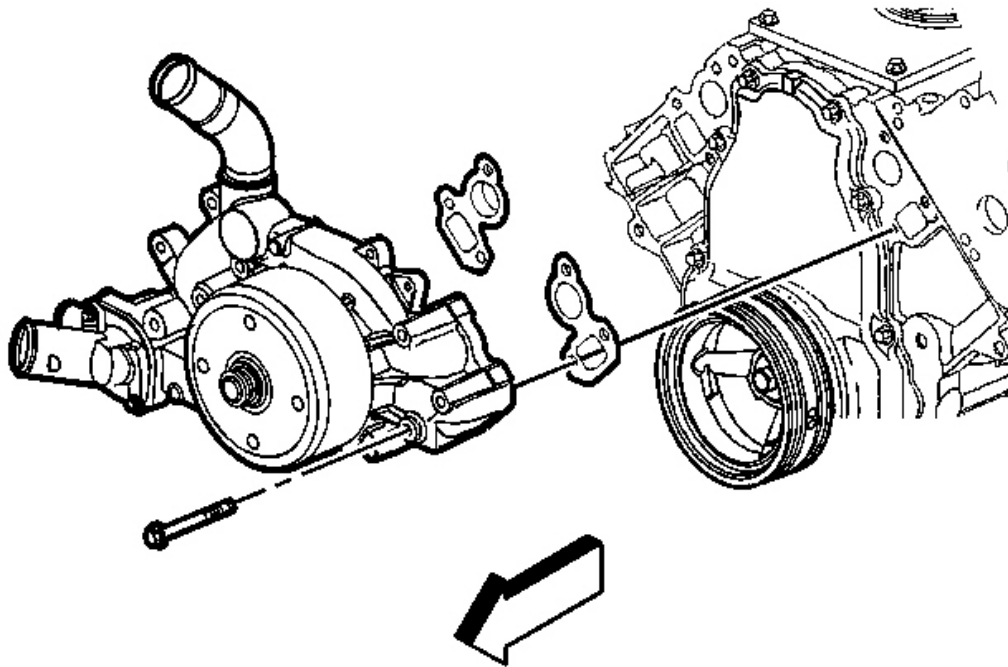

Fig. 78: Water Pump & Bolt
Courtesy of GENERAL MOTORS CORP.

16. Remove the water pump bolts.
17. Remove the water pump and gaskets.
18. Discard the water pump gaskets.

Installation Procedure

IMPORTANT: All gaskets surfaces are to be free of oil or other foreign material during assembly.

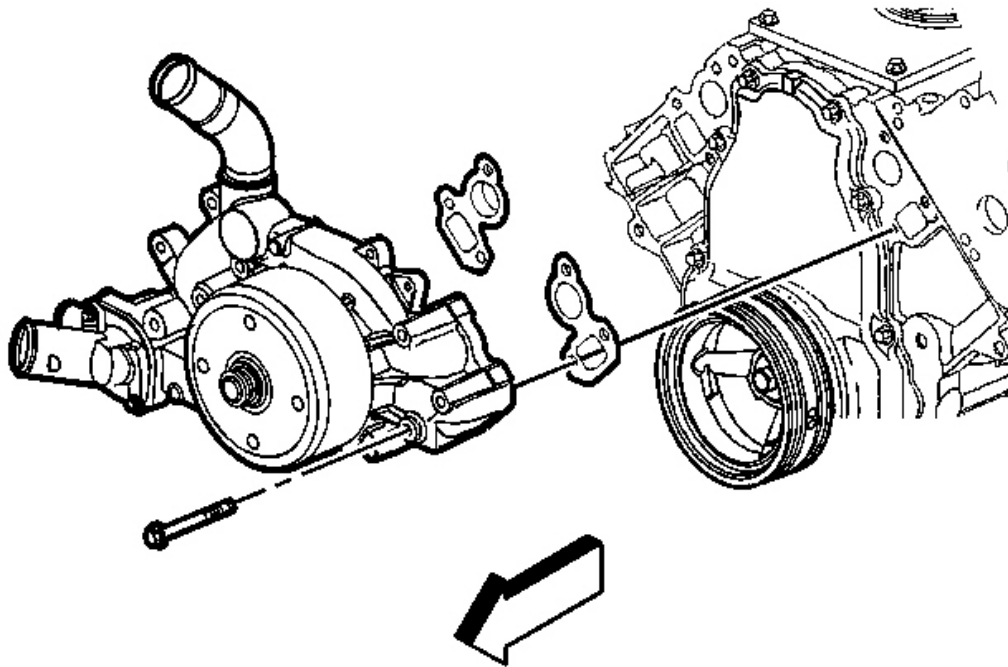

Fig. 79: Water Pump & Bolt
Courtesy of GENERAL MOTORS CORP.

NOTE: Refer to Fastener Notice in Cautions and Notices.

1. Install the water pump and NEW gaskets.
2. Install the water pump bolts.

Tighten:

1. Tighten the water pump bolts a first pass to 15 N.m (11 lb ft).
2. Tighten the water pump bolts a final pass to 30 N.m (22 lb ft).

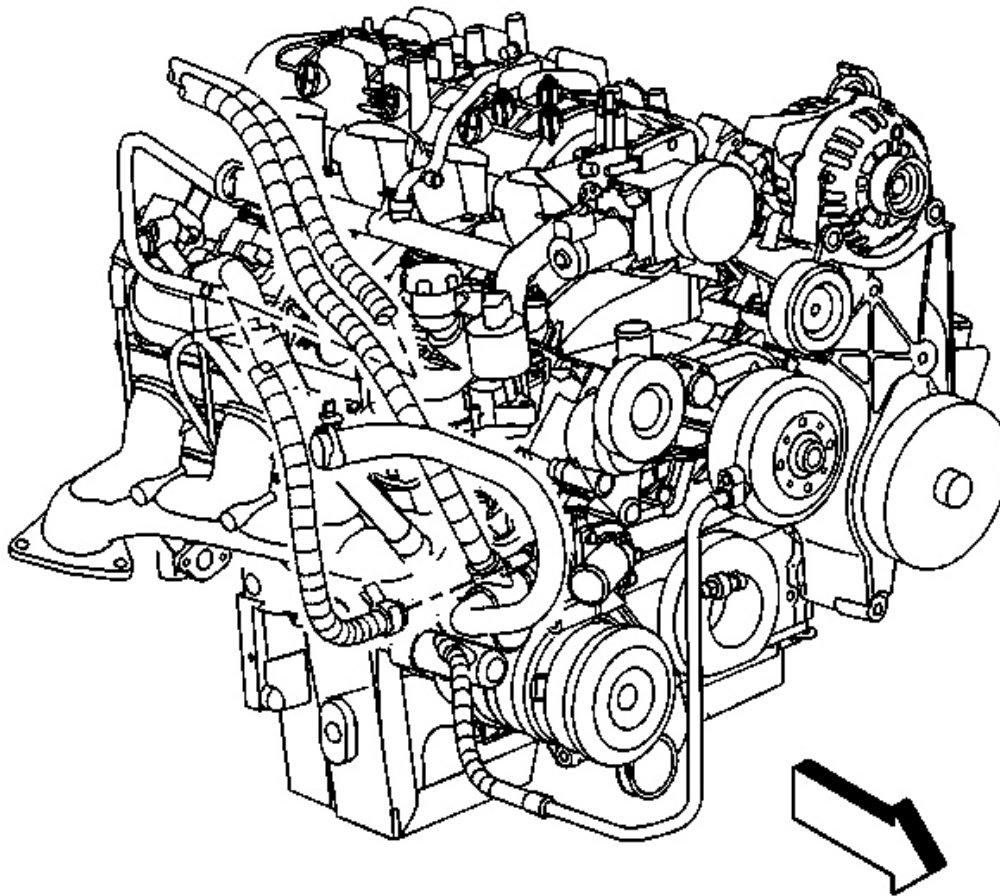

Fig. 80: Heater Inlet Hose
Courtesy of GENERAL MOTORS CORP.

3. Install the heater inlet hose to the water pump.
4. Position the heater inlet hose clamp at the water pump.

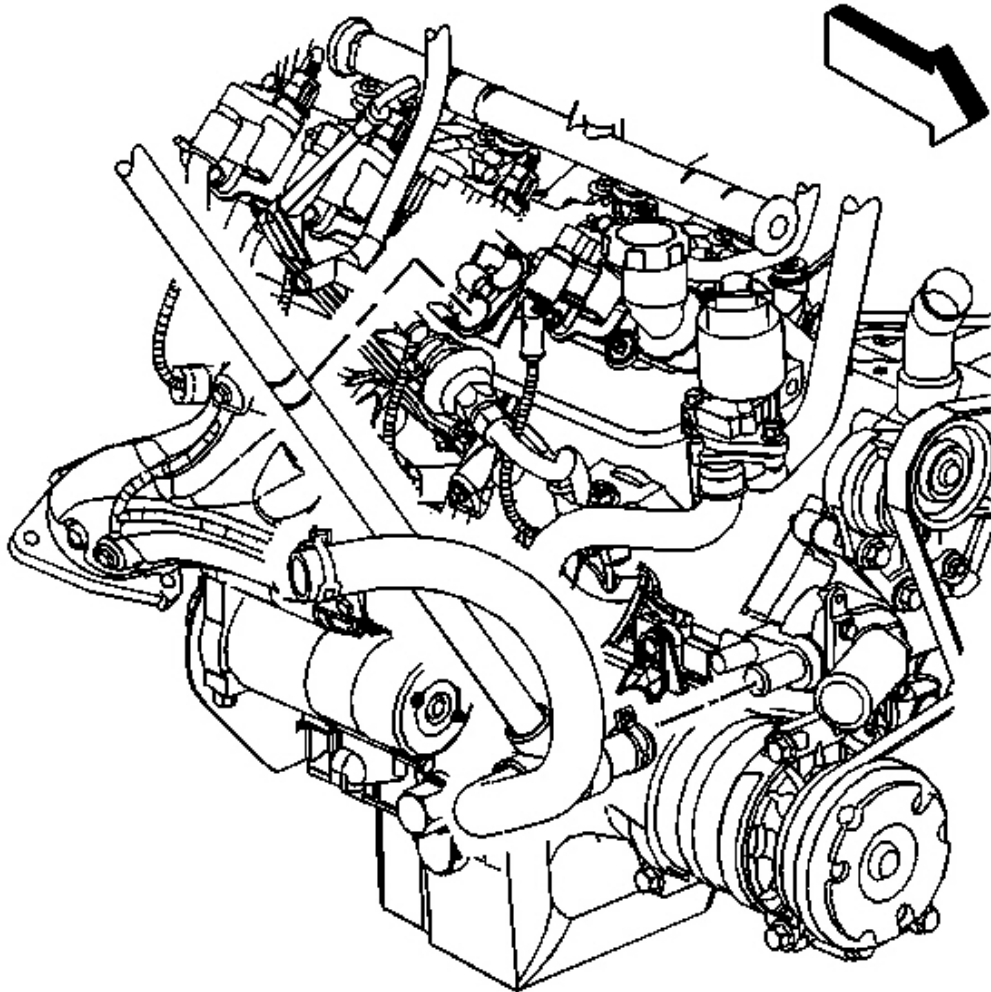

Fig. 81: Surge Tank Outlet Hose
Courtesy of GENERAL MOTORS CORP.

5. Install the surge tank outlet hose to the water pump.
6. Position the surge tank outlet hose clamp at the water pump.

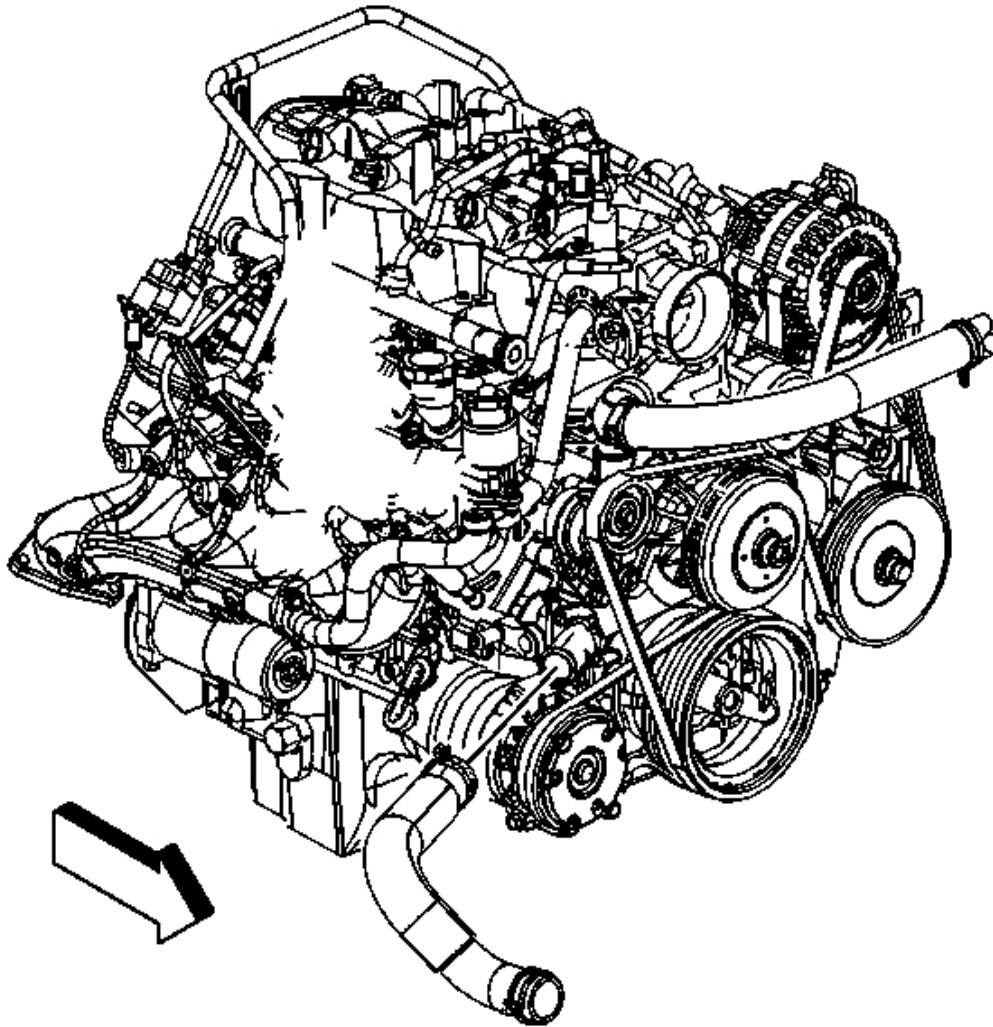

Fig. 82: Outlet Hose & Water Pump (4.8, 5.3, & 6.0L)
Courtesy of GENERAL MOTORS CORP.

7. Install the outlet hose to the water pump.
8. Position the outlet hose clamp at the water pump.
9. Install the accessory drive belt. Refer to **Drive Belt Replacement - Accessory** in Engine Mechanical - 6.0L (LQ4).
10. Install the fan blade. Refer to **Fan Replacement** .

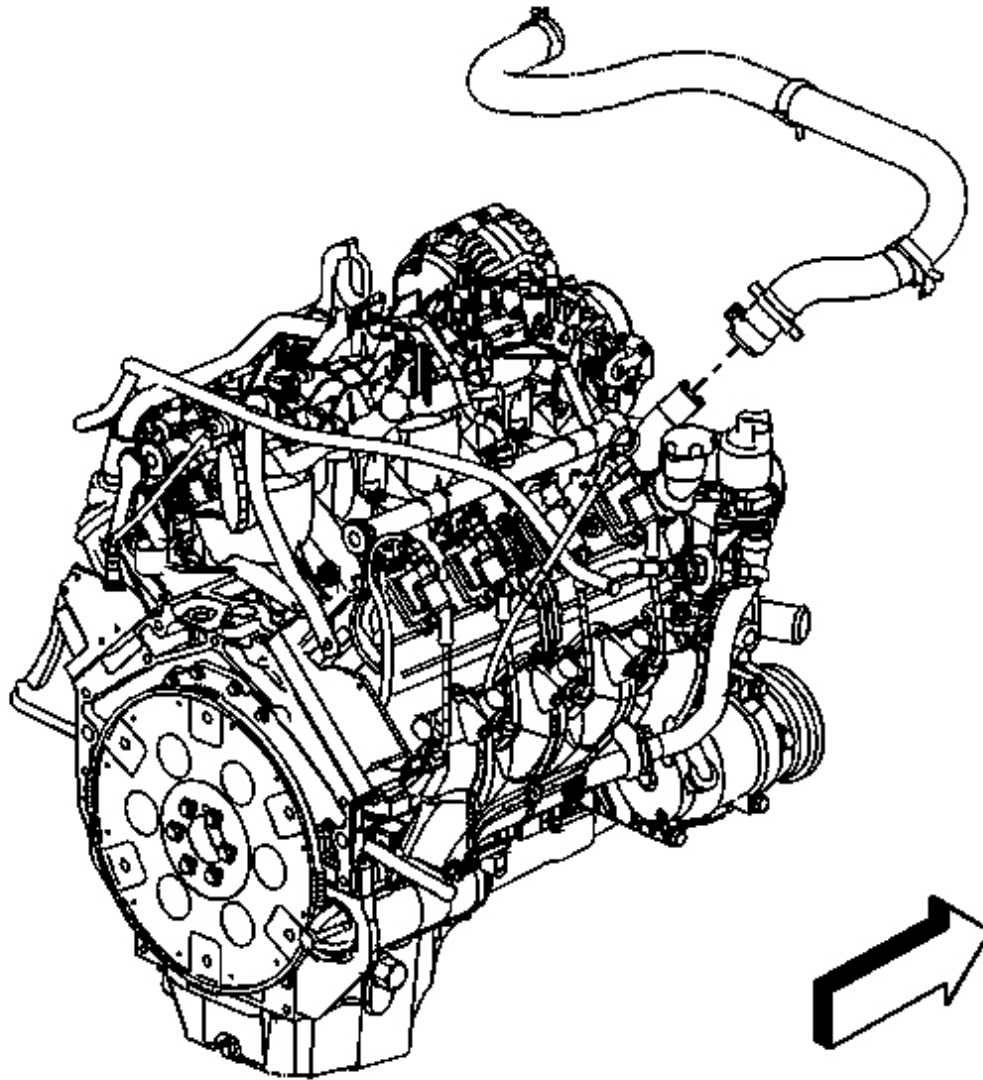

Fig. 83: Inlet Hose & Water Pump (4.8, 5.3, & 6.0L)
Courtesy of GENERAL MOTORS CORP.

11. Install the inlet hose to the water pump.
12. Position the inlet hose clamp at the water pump.

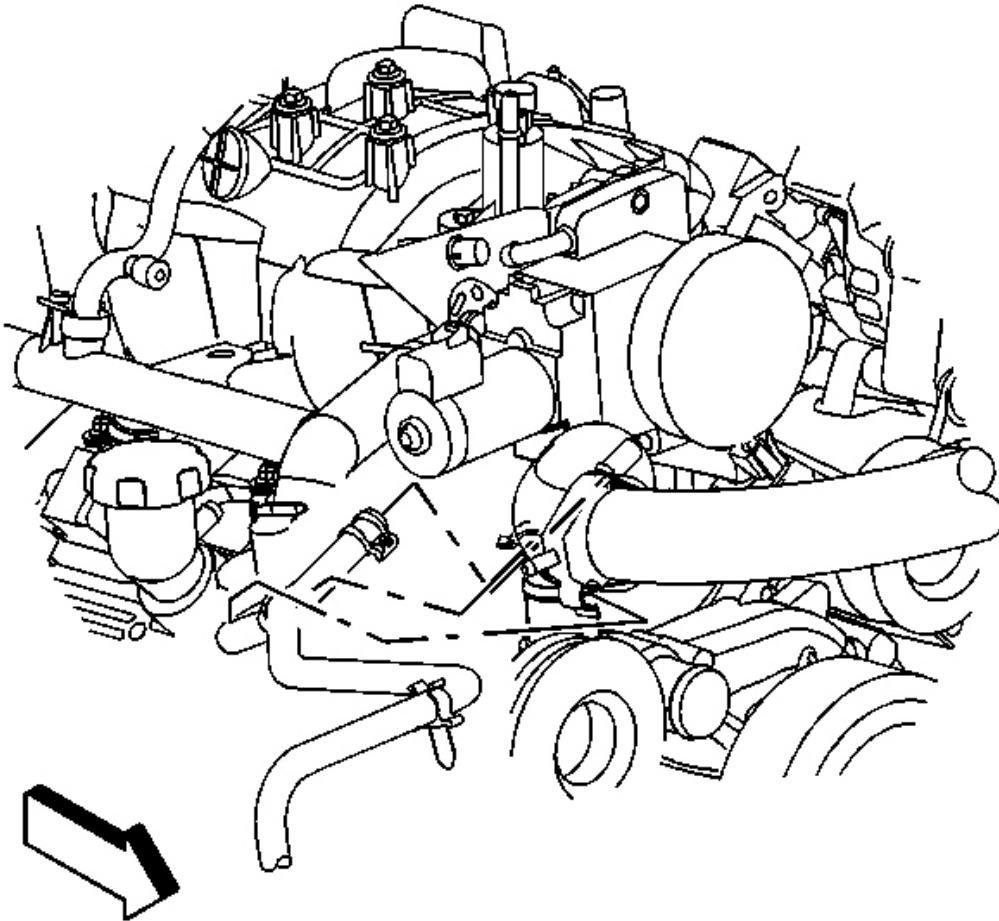

Fig. 84: Vent Inlet Hose At Throttle Body
Courtesy of GENERAL MOTORS CORP.

13. Install the engine vent inlet hose to the radiator hose clips.

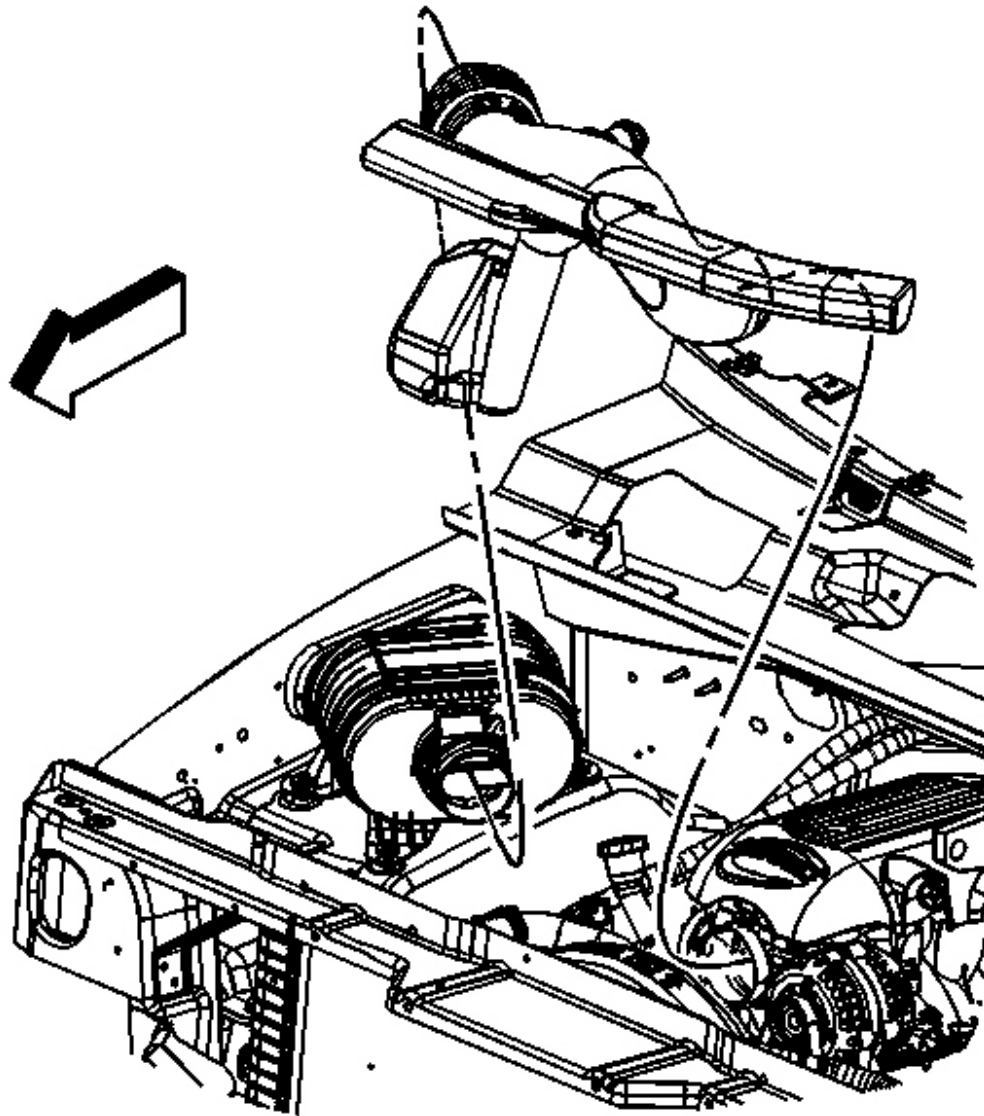

Fig. 85: Air Cleaner Outlet Duct
Courtesy of GENERAL MOTORS CORP.

IMPORTANT: Align the arrow at the throttle body end of the duct with the throttle body attaching stud.

15. Install the radiator inlet hose clip to the outlet duct.

www.4x4us.net

www.4x4us.net

16. Tighten the air cleaner outlet duct clamps at the following locations:

- Throttle body
- MAF/IAT sensor

Tighten: Tighten the air cleaner outlet duct clamp screws to 7 N.m (62 lb in).

17. Fill the cooling system. Refer to **Draining and Filling Cooling System** .

DRAIN COCK REPLACEMENT

Removal Procedure

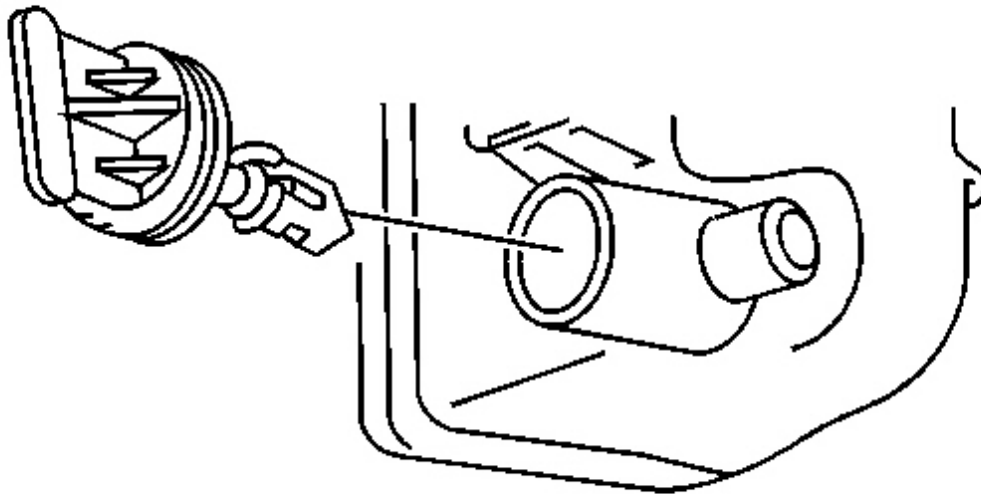

Fig. 86: Radiator Drain Cock
Courtesy of GENERAL MOTORS CORP.

1. Drain the cooling system. Refer to **Draining and Filling Cooling System** .
2. Remove the radiator drain cock.

Installation Procedure

www.4x4us.net

www.4x4us.net

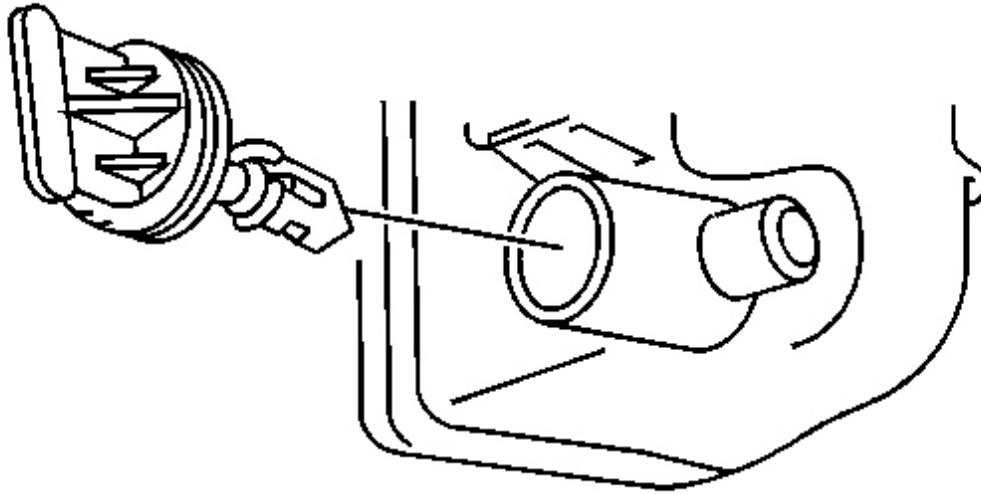

Fig. 87: Radiator Drain Cock
Courtesy of GENERAL MOTORS CORP.

1. Install the radiator drain cock.
2. Fill the cooling system. Refer to **Draining and Filling Cooling System** .

FAN SHROUD REPLACEMENT

Removal Procedure

1. Loosen the air cleaner outlet duct clamps from the throttle body.
2. Loosen the air cleaner outlet duct clamps from the mass airflow sensor.
3. Remove the air cleaner outlet duct.

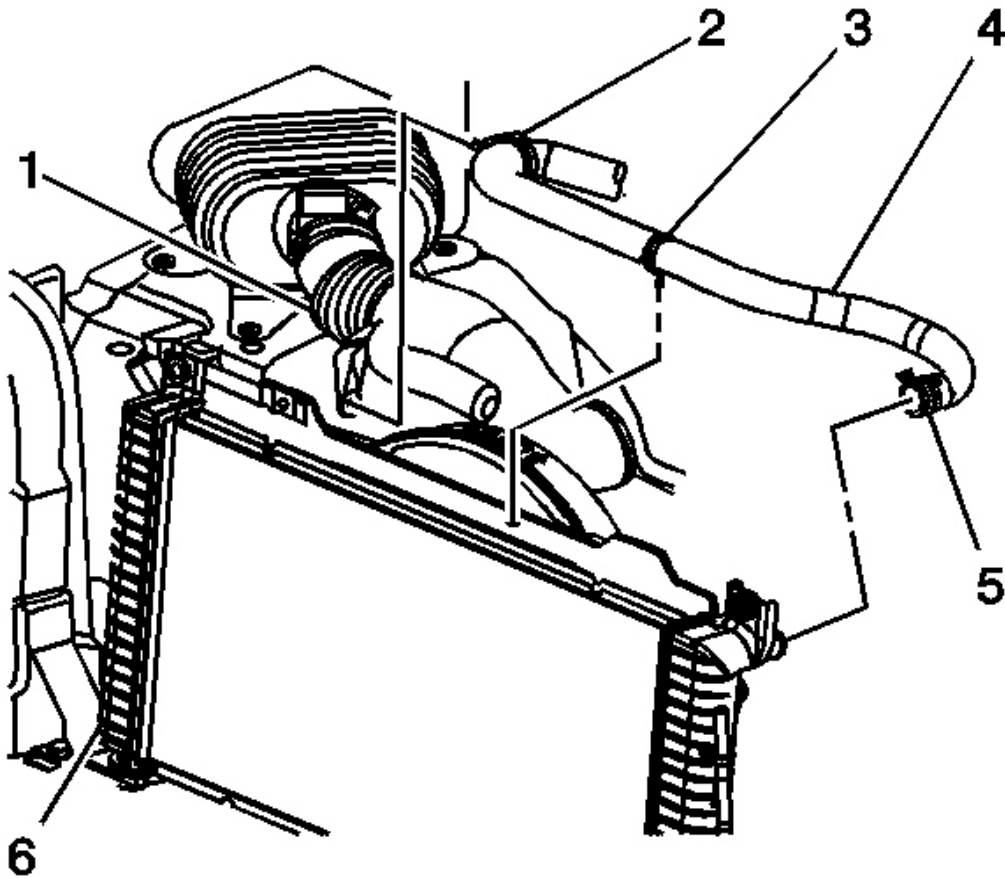

Fig. 88: Radiator Hose & Radiator (Inlet)
Courtesy of GENERAL MOTORS CORP.

4. Remove the radiator inlet hose from the fan shroud retainer (3).
5. Remove the bolt (5) from the fan shroud (3).
6. Remove the transmission oil cooler line from the fan shroud retainer.
7. Rotate the slip ring from under the fan shroud.

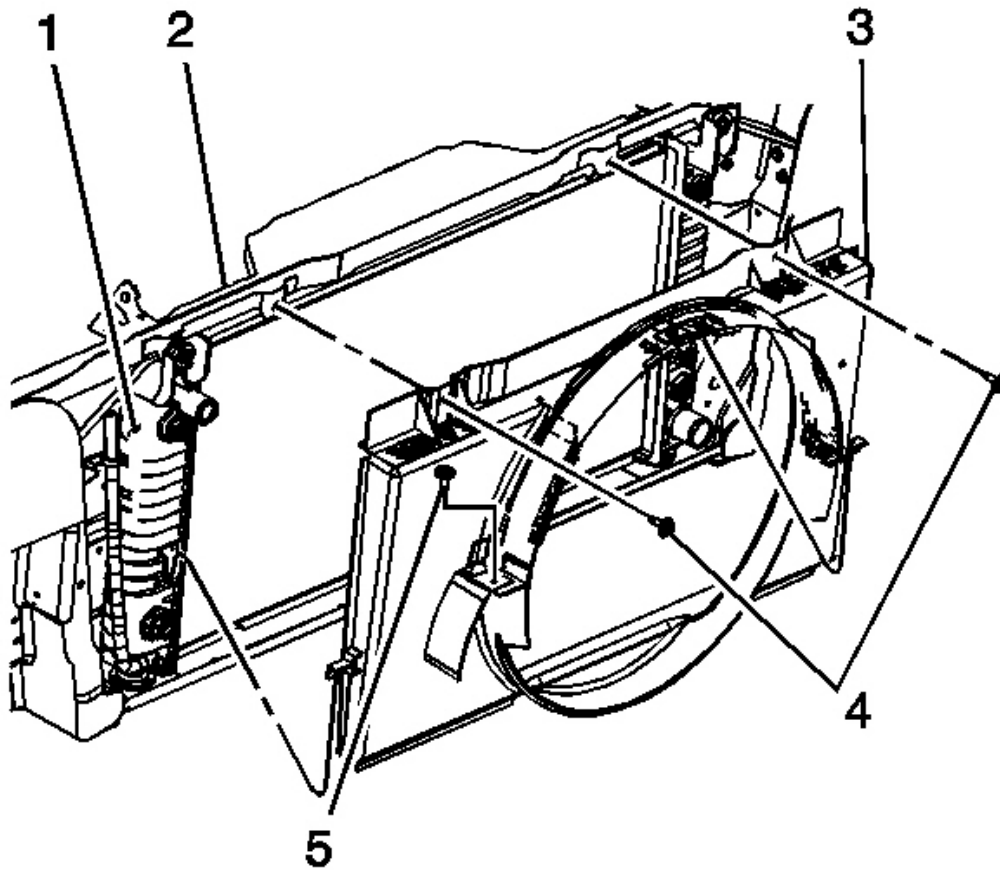

Fig. 89: Identifying Fan Shroud
Courtesy of GENERAL MOTORS CORP.

8. Remove the bolts (4) from the fan shroud (3).
9. Remove the fan shroud (3) from the vehicle.

Installation Procedure

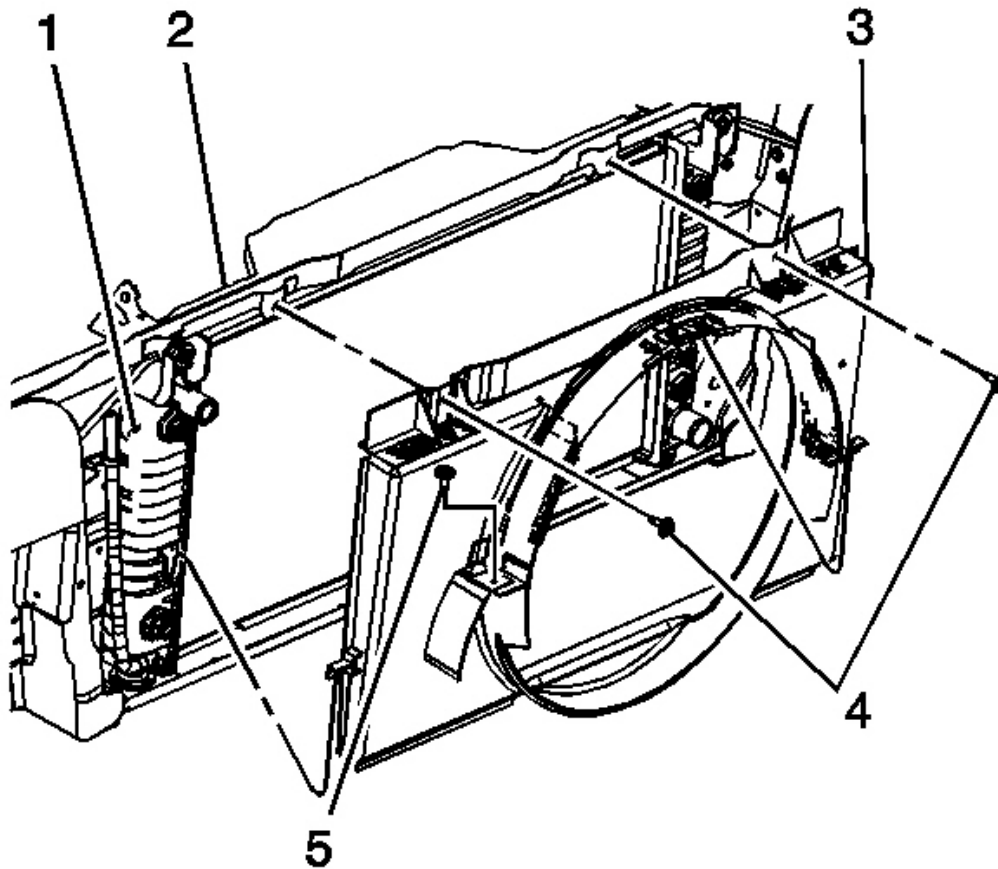

Fig. 90: Identifying Fan Shroud
Courtesy of GENERAL MOTORS CORP.

NOTE: Refer to Fastener Notice in Cautions and Notices.

1. Install the fan shroud (3) to the vehicle.
2. Install the bolts (4) to the fan shroud (3).

Tighten: Tighten the bolts to 9 N.m (80 lb in).

3. Install the transmission oil cooler line to the fan shroud retainer.
4. Rotate the slip ring to the original position.
5. Install the bolt (5) to the fan shroud (3).

Tighten: Tighten the bolt to 5 N.m (44 lb in).
www.4x4us.net

www.4x4us.net

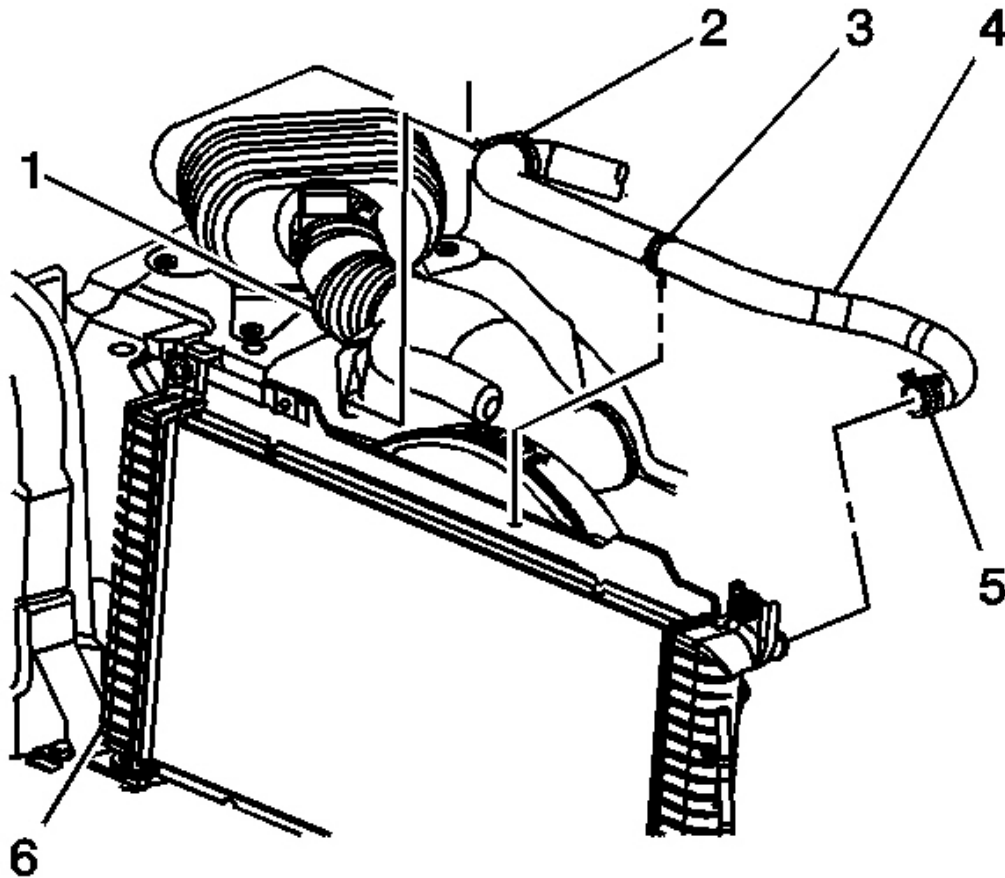

Fig. 91: Radiator Hose & Radiator (Inlet)
Courtesy of GENERAL MOTORS CORP.

6. Install the radiator inlet hose to the fan shroud retainer (3).
7. Install the air cleaner outlet duct.
8. Tighten the air cleaner outlet duct clamp at the throttle body.

Tighten: Tighten the clamp screw to 7 N.m (62 lb in).

9. Tighten the air cleaner outlet duct clamp at the mass airflow sensor.

www.4x4us.net

Tighten: Tighten the clamp screw to 7 N.m (62 lb in).

www.4x4us.net

Removal Procedure

1. Drain the cooling system. Refer to **Draining and Filling Cooling System** .

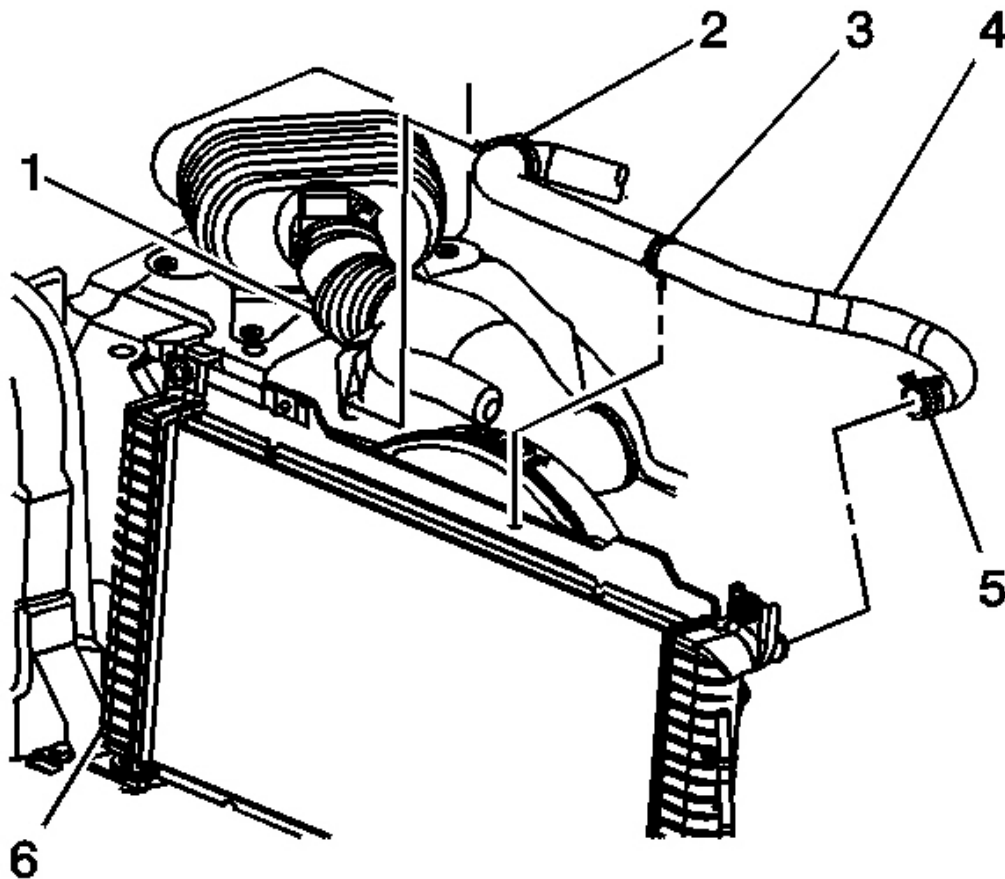

Fig. 92: Radiator Hose & Radiator (Inlet)
Courtesy of GENERAL MOTORS CORP.

2. Reposition the radiator inlet hose clamp (5) from the radiator (6).
3. Remove the radiator inlet hose (4) from the radiator (6).
4. Remove the fan shroud. Refer to **Fan Shroud Replacement** .

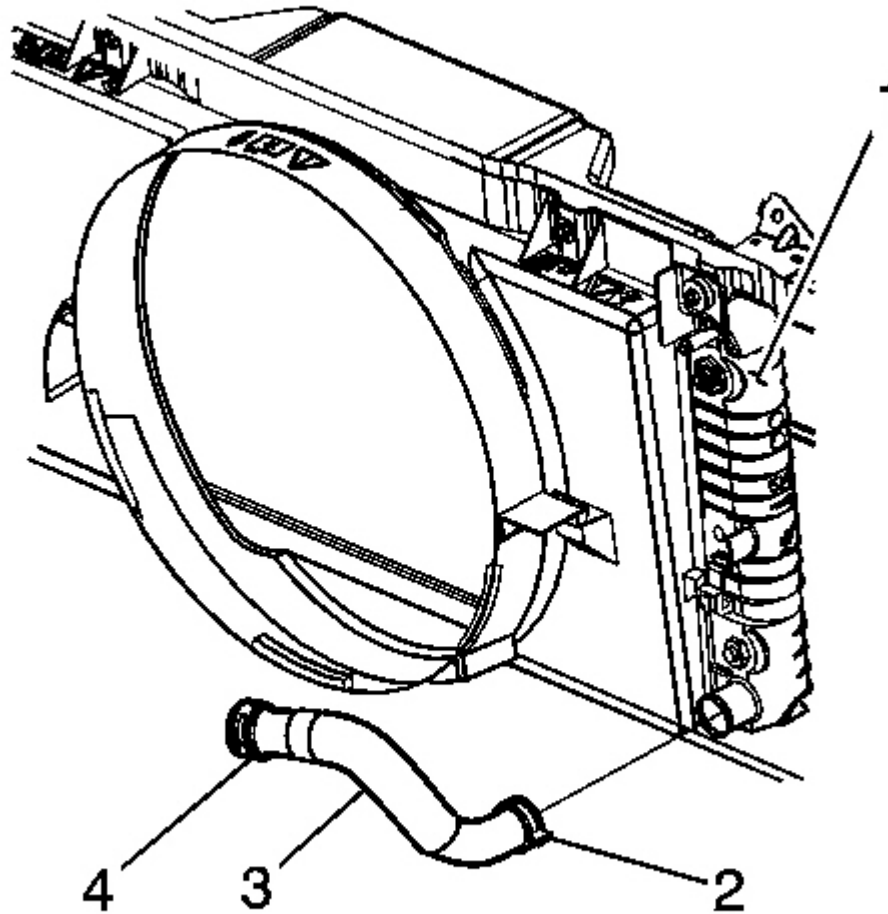

Fig. 93: Radiator Hose & Radiator (Outlet)
Courtesy of GENERAL MOTORS CORP.

5. Reposition the radiator outlet hose clamp (2) from the radiator (1).
6. Remove the radiator outlet hose (3) from the radiator (1).

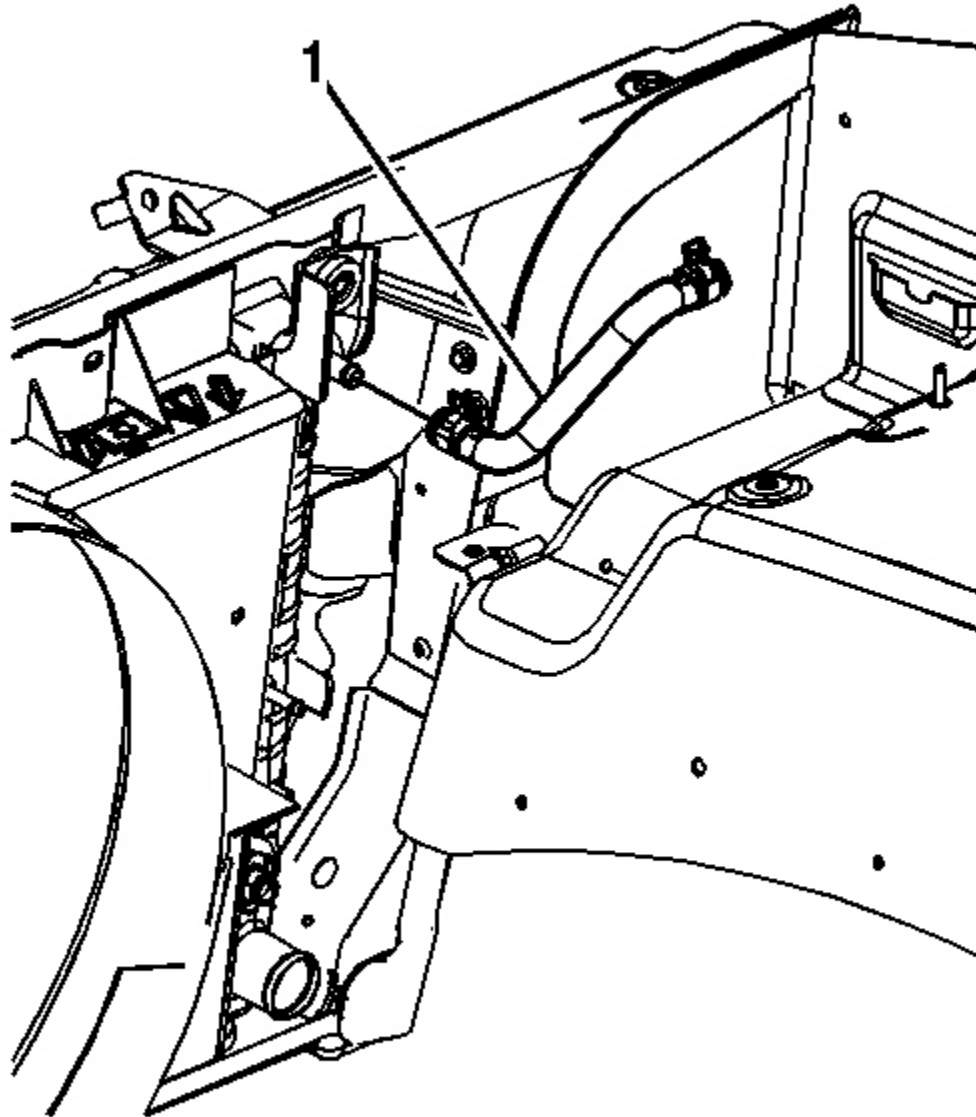

Fig. 94: Surge Tank Hose & Radiator (Inlet)
Courtesy of GENERAL MOTORS CORP.

7. Reposition the surge tank inlet hose clamp from the radiator.
8. Remove the surge tank inlet hose (1) from the radiator.

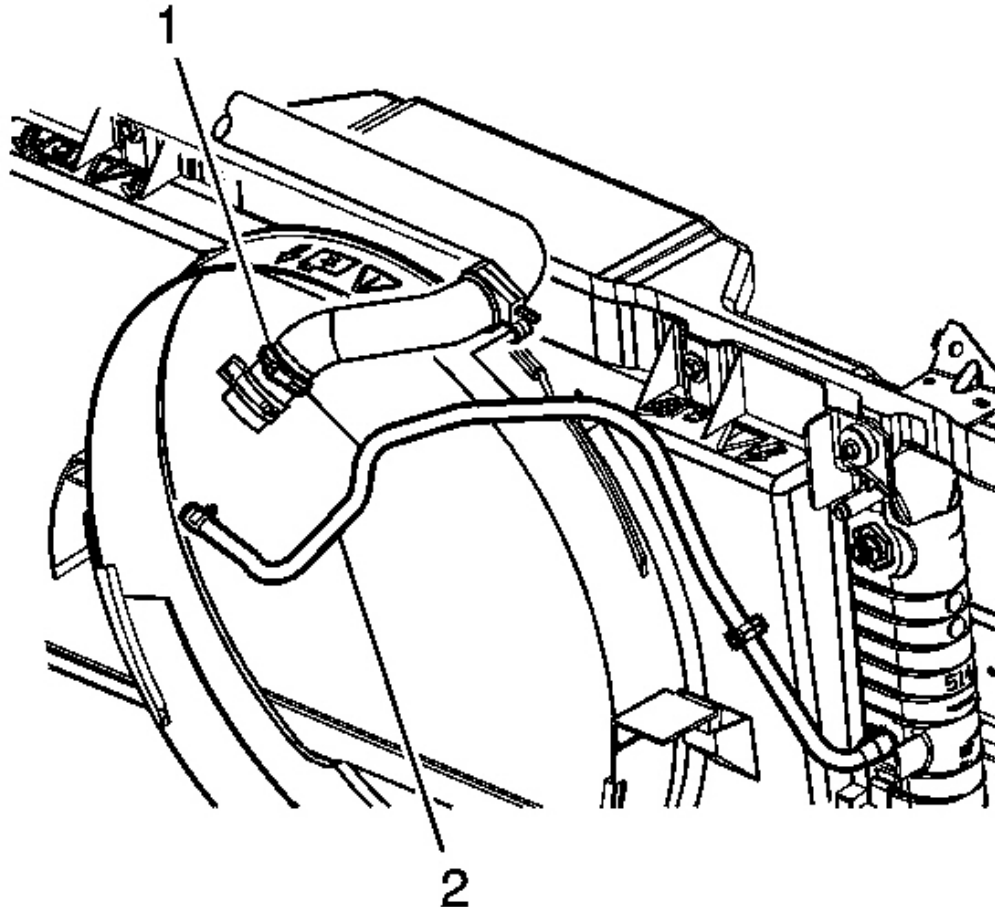

Fig. 95: Radiator Vent Inlet Hose
Courtesy of GENERAL MOTORS CORP.

9. Reposition the radiator vent inlet hose clamp from the radiator.
10. Remove the radiator vent inlet hose (2) from the radiator.
11. Remove the engine oil cooler lines from the radiator. Refer to **Engine Oil Cooler Pipe/Hose Quick Connect Fitting** .
12. Remove the transmission oil cooler lines from the radiator. Refer to **Transmission Fluid Cooler Line Quick Connect Fitting** in Automatic Transmission 4L60E/4L65E.

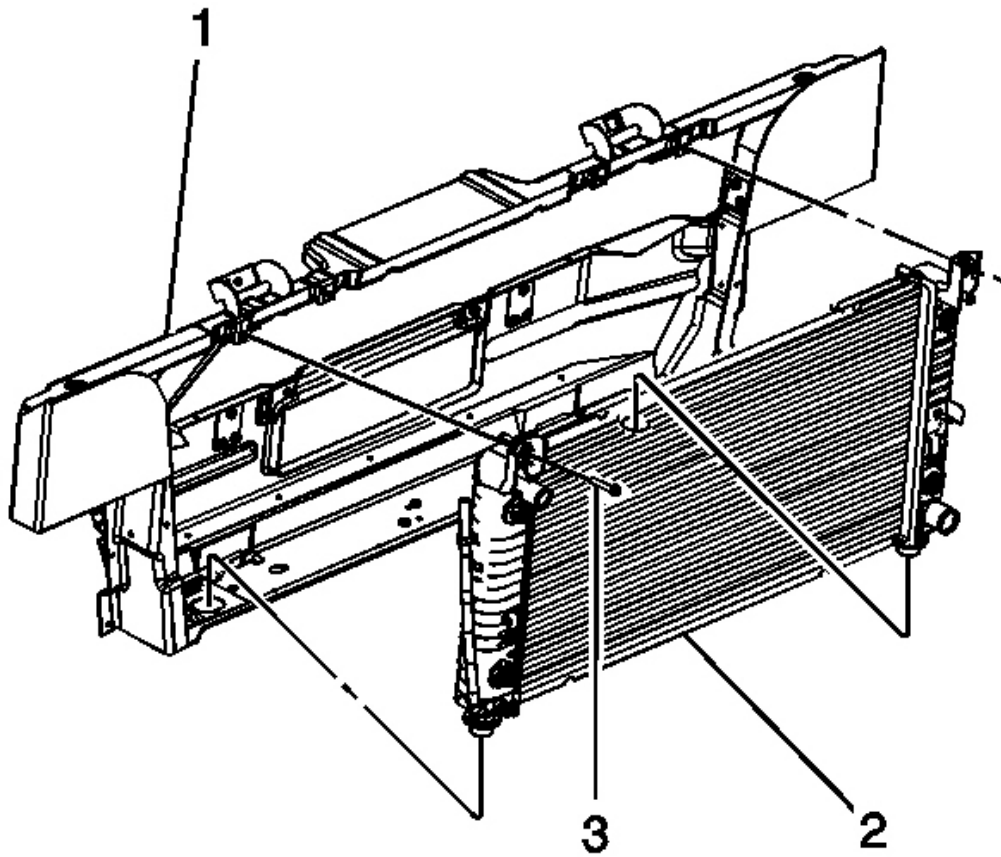

Fig. 96: Identifying Radiator
Courtesy of GENERAL MOTORS CORP.

13. Remove the radiator bolts (3) from the radiator (2).
14. Remove the radiator (2) from the vehicle (1).

Installation Procedure

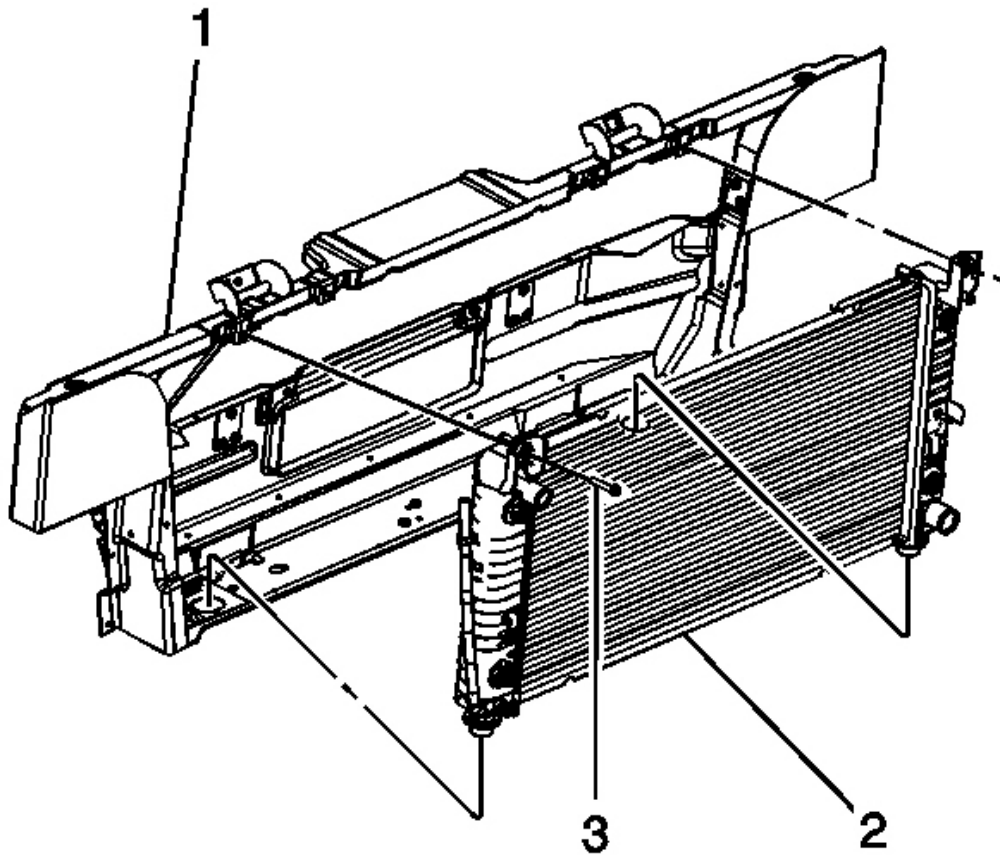

Fig. 97: Identifying Radiator
Courtesy of GENERAL MOTORS CORP.

NOTE: Refer to Fastener Notice in Cautions and Notices.

1. Install the radiator (2) to the vehicle (1).
2. Install the radiator bolts (3) to the radiator (2).

Tighten: Tighten the bolts to 25 N.m (18 lb ft).

3. Install the engine oil cooler lines to the radiator. Refer to Engine Oil Cooler Pipe/Hose Quick Connect Fitting.
4. Install the transmission oil cooler lines to the radiator. Refer to Transmission Fluid Cooler Line Quick Connect Fitting in Automatic Transmission 4L60E/4L65E.

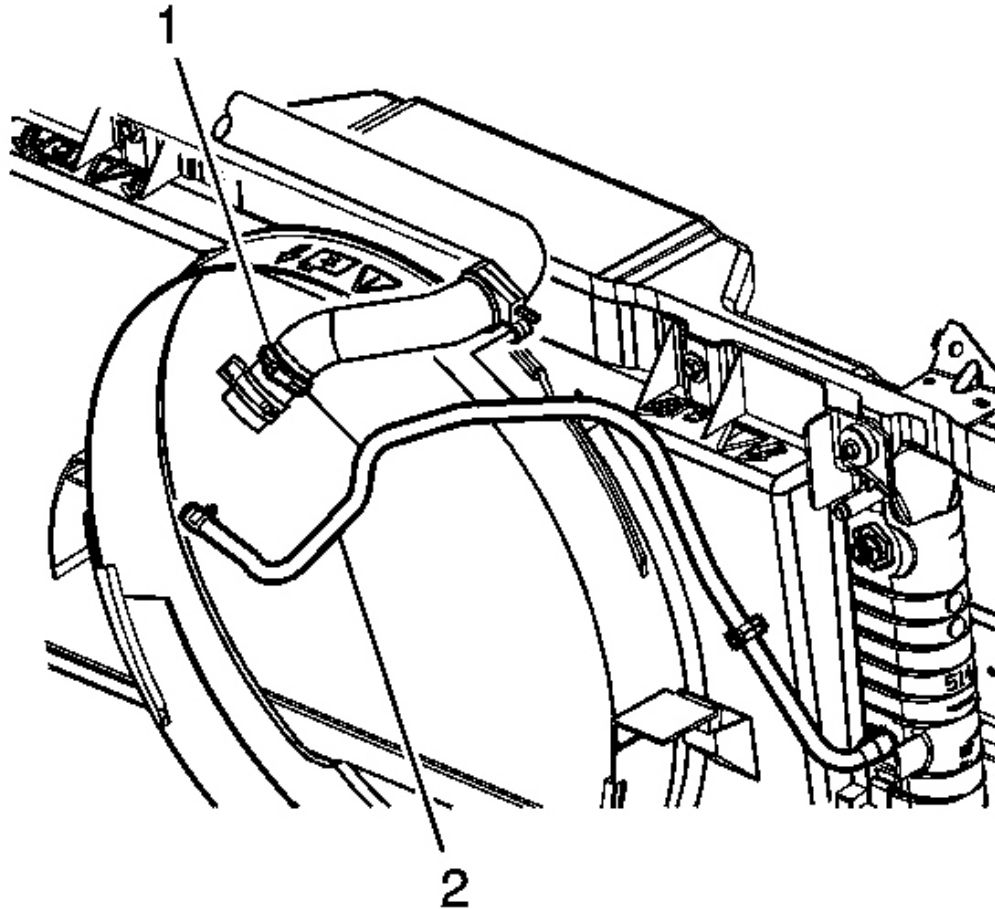

Fig. 98: Radiator Vent Inlet Hose
Courtesy of GENERAL MOTORS CORP.

5. Install the radiator vent inlet hose (2) to the radiator.
6. Position the radiator vent inlet hose clamp to the radiator.
7. Install the surge tank inlet hose (1) to the radiator.

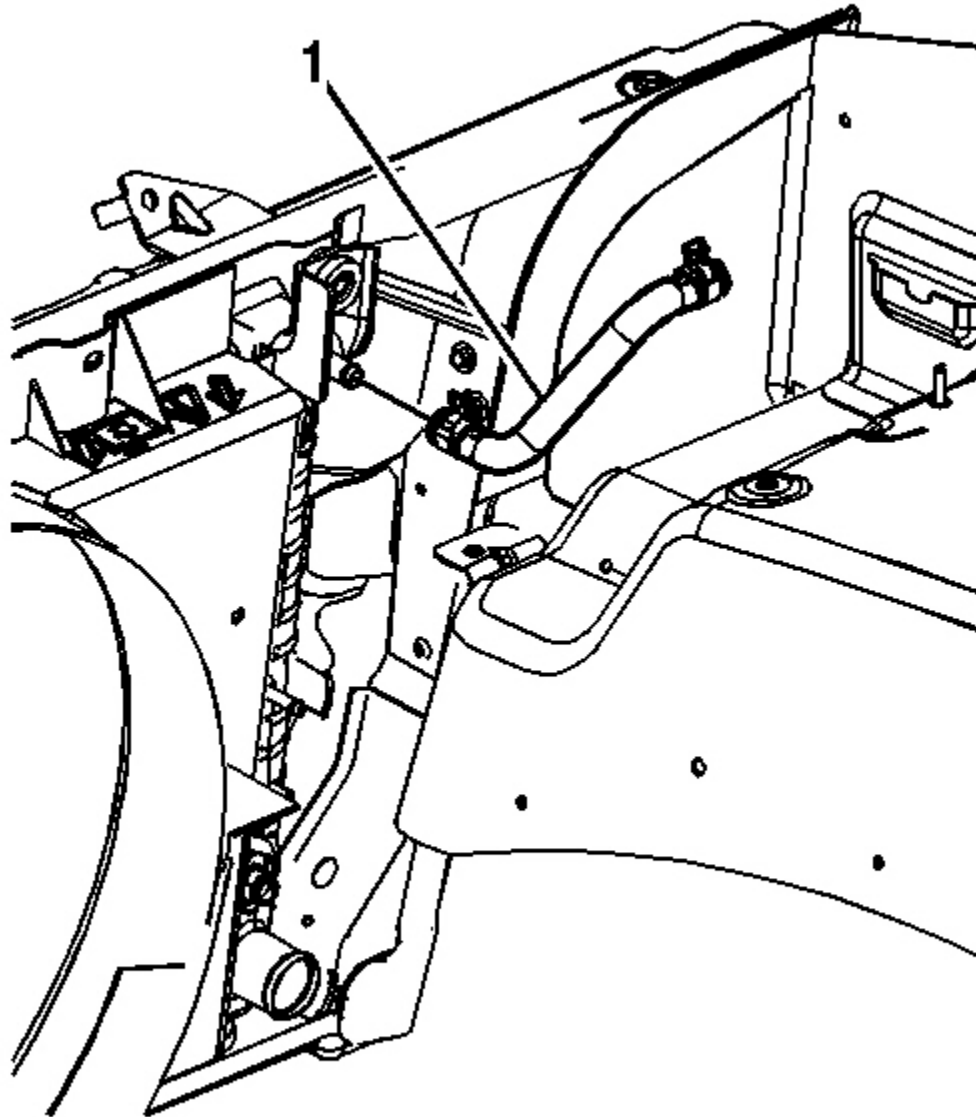

Fig. 99: Surge Tank Hose & Radiator (Inlet)
Courtesy of GENERAL MOTORS CORP.

8. Position the surge tank inlet hose clamp to the radiator.

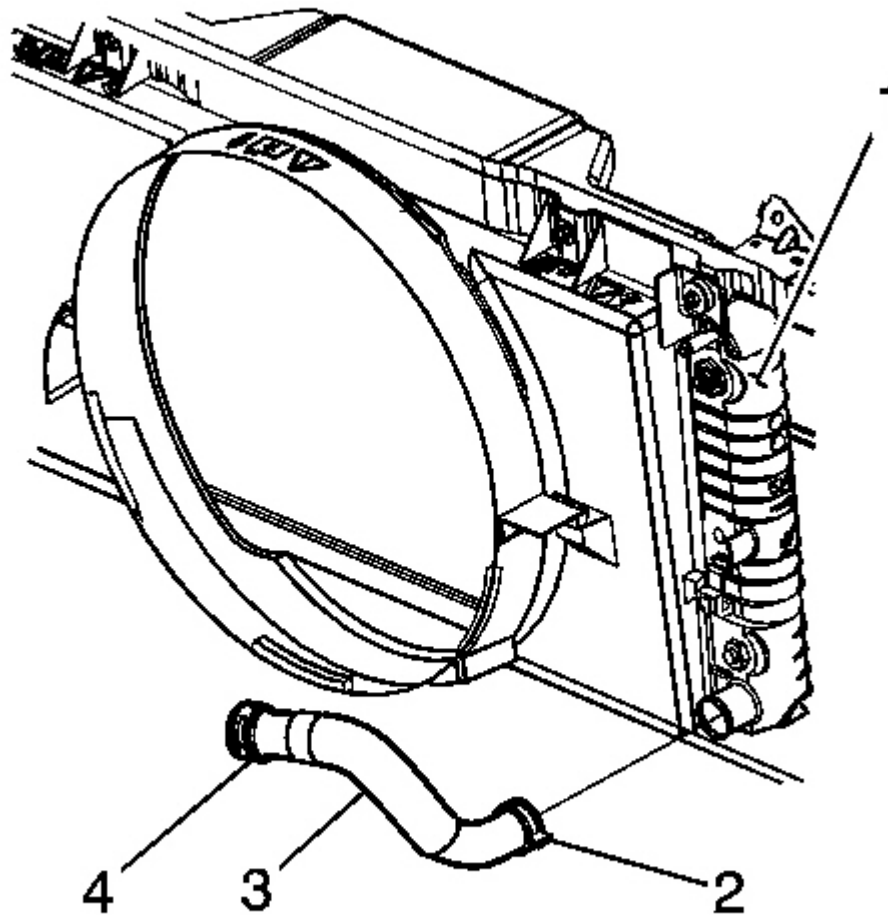

Fig. 100: Radiator Hose & Radiator (Outlet)
Courtesy of GENERAL MOTORS CORP.

9. Install the radiator outlet hose (3) to the radiator (1).
10. Position the radiator outlet hose clamp (2) to the radiator (1).
11. Install the fan shroud. Refer to **Fan Shroud Replacement** .

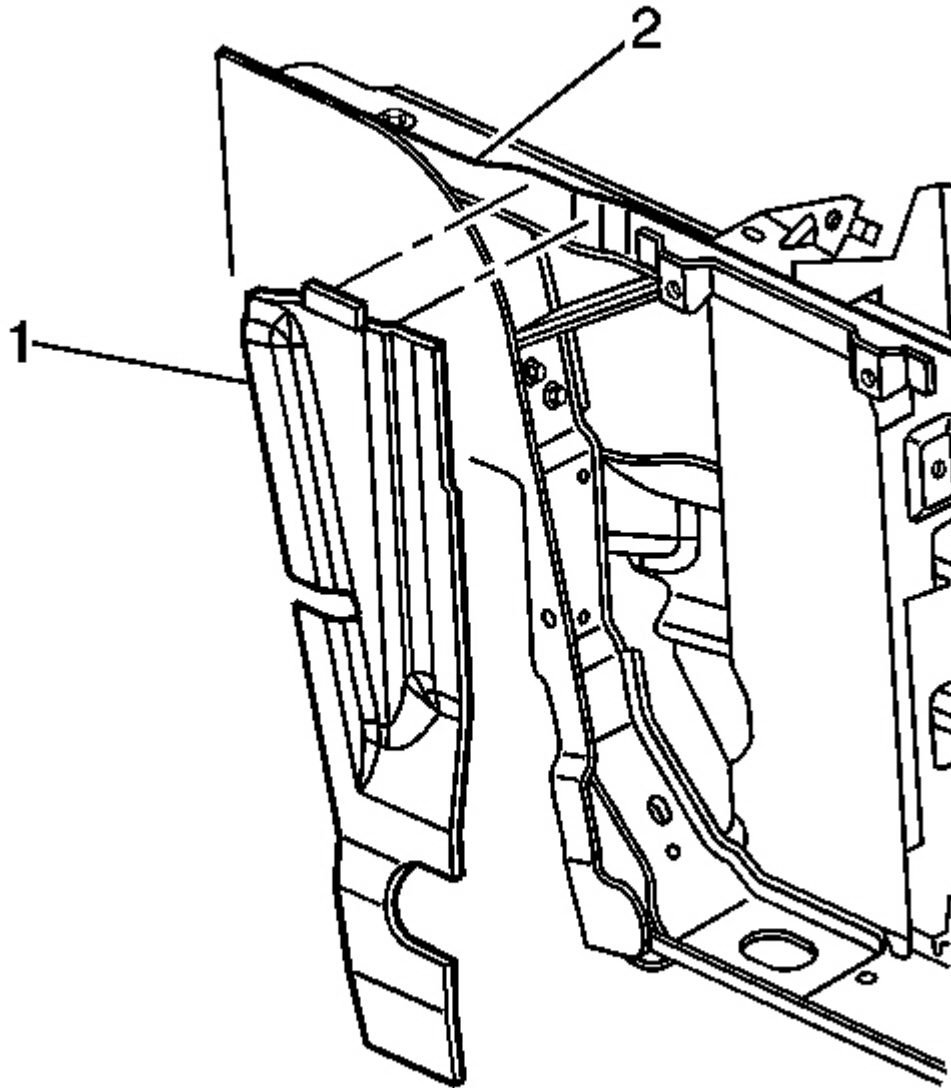

Fig. 102: Radiator Air Baffles
Courtesy of GENERAL MOTORS CORP.

1. Remove the radiator air baffle retainers.
2. Remove the radiator air baffles (1) from the vehicle (2).

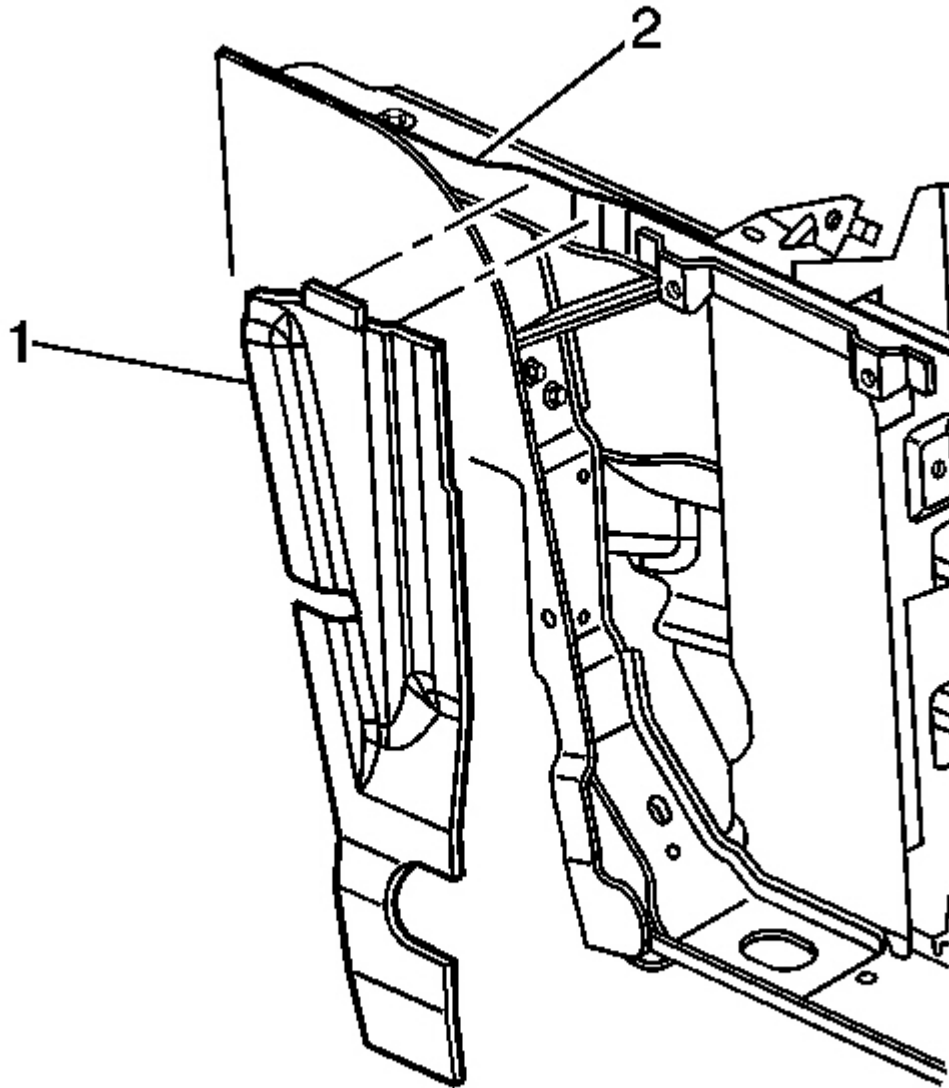

Fig. 103: Radiator Air Baffles
Courtesy of GENERAL MOTORS CORP.

1. Install the radiator air baffles (1) to the vehicle (2).
2. Install the radiator air baffle retainers.

1. Drain the cooling system/engine block. Refer to Draining and Filling Cooling System .
2. Raise and suitably support the vehicle. Refer to Lifting and Jacking the Vehicle in General Information.

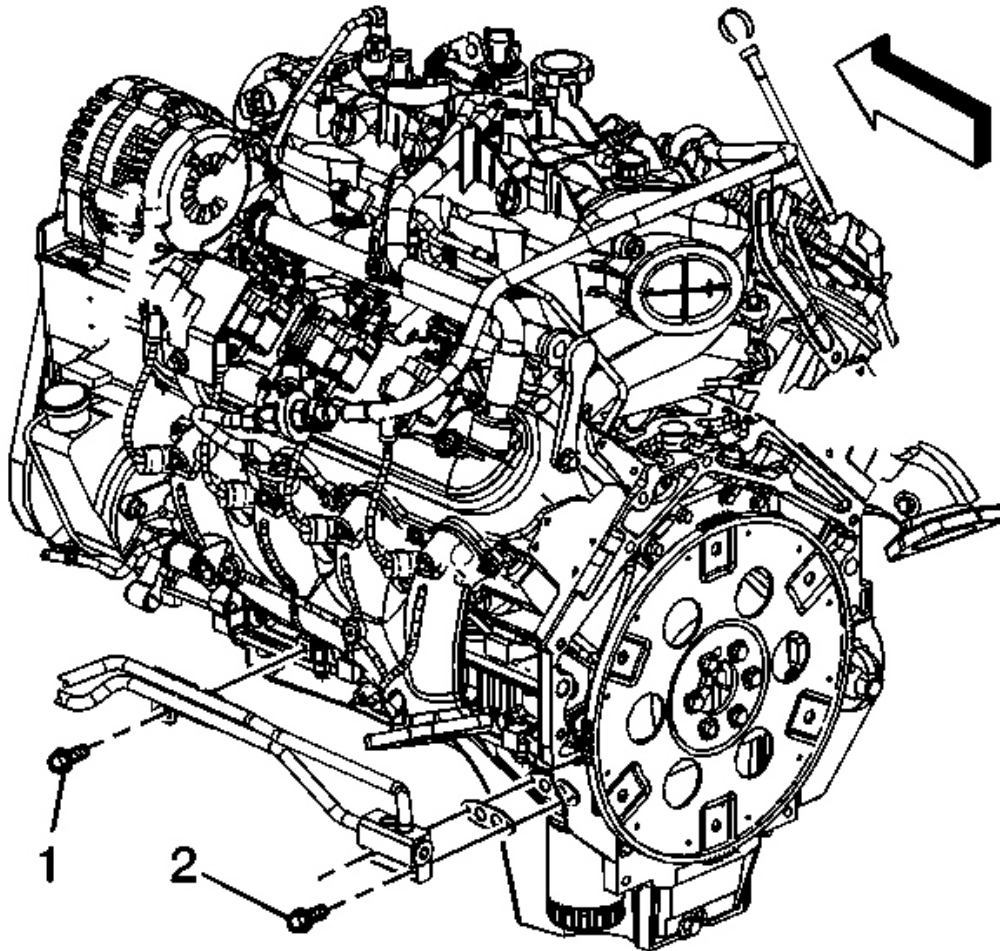

Fig. 104: Oil Cooler Hose Bracket Bolt & Adapter Bolts
Courtesy of GENERAL MOTORS CORP.

3. Remove the oil cooler hose bracket bolt (1).
4. Remove the oil cooler hose adapter bolts (2).
5. Remove and discard the oil cooler hose adapter gasket.
6. Position the oil cooler hose adapter end out of the way.

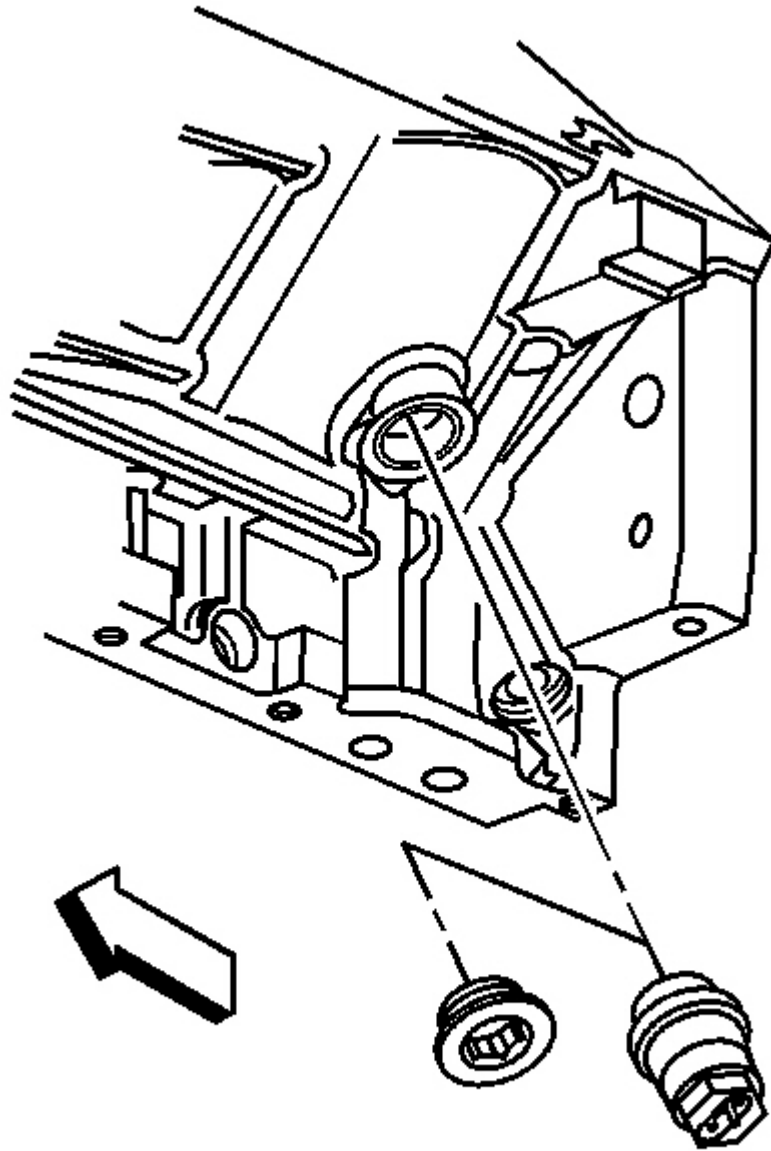

Fig. 105: Installing Engine Coolant Heater In Place Of Drain Plug
Courtesy of GENERAL MOTORS CORP.

NOTE: Refer to Fastener Notice in Cautions and Notices.
www.4x4us.net

7. Install the coolant heater in place of the drain plug.

Tighten: Tighten the coolant heater to 50 N.m (37 lb ft).
www.4x4us.net

www.4x4us.net

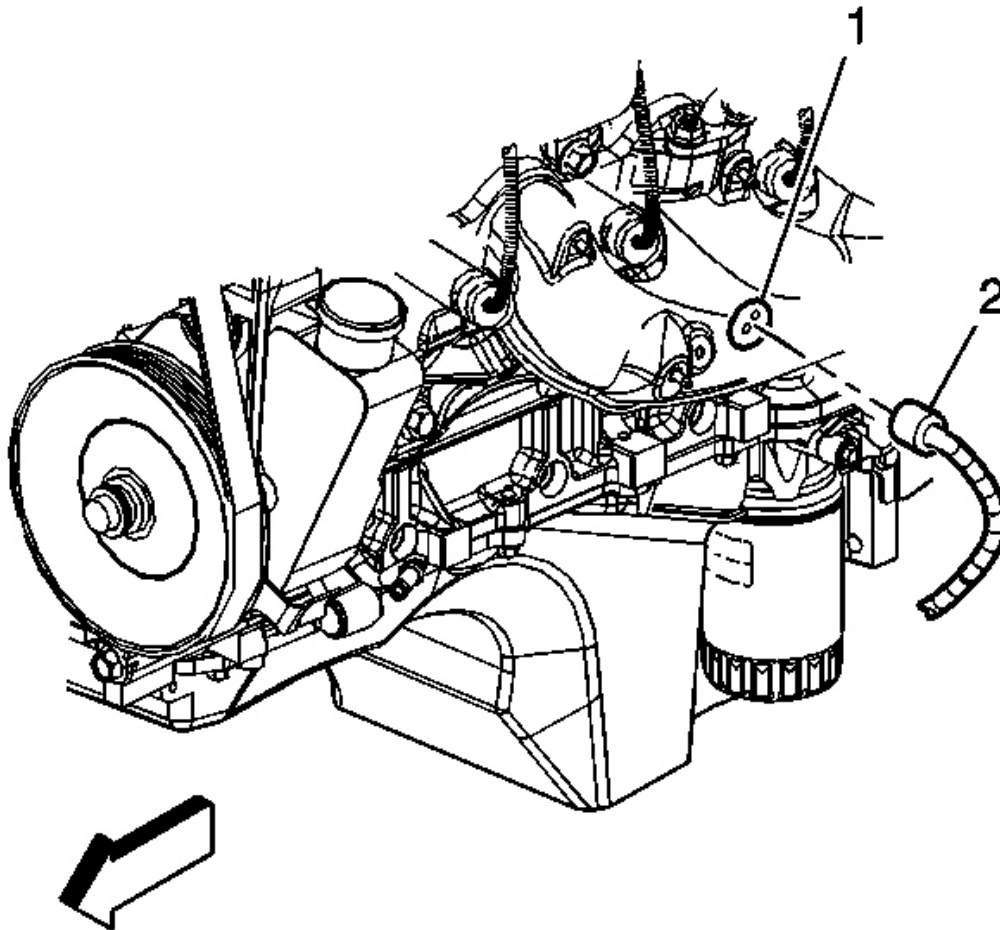

Fig. 106: Engine Coolant Heater Cord Electrical Connector & Coolant Heater
Courtesy of GENERAL MOTORS CORP.

IMPORTANT: The engine coolant heater cord must not touch the engine, hot pipes, manifold, or any moving parts. Always keep the electrical cord neatly rolled up with the end of the cord tucked in the center of the coil and secured in place.

8. Push the engine coolant heater cord electrical connector (2) firmly into the coolant heater (1).

www.4x4us.net

www.4x4us.net

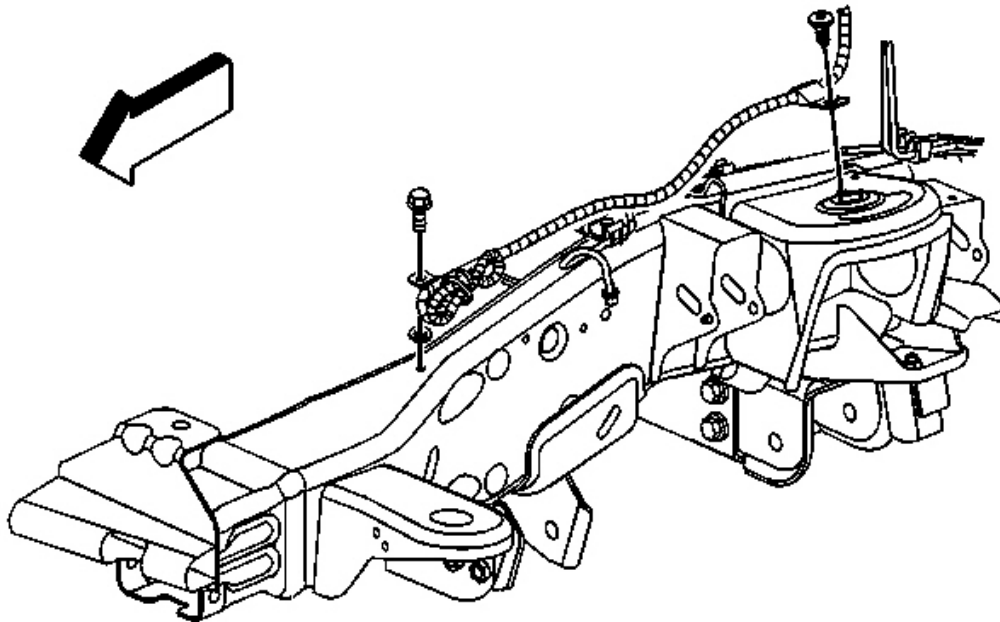

Fig. 107: Engine Coolant Heater Cord
Courtesy of GENERAL MOTORS CORP.

NOTE: The heater cord must not touch the engine, hot pipes, manifold, or any moving parts. Route the cord to the left front of the engine compartment securing with tie straps as necessary to prevent damage.

9. Place the cord into position.
10. Install the heater cord bolt and retainer.

Tighten: Tighten the heater cord bolt to 8 N.m (71 lb in).

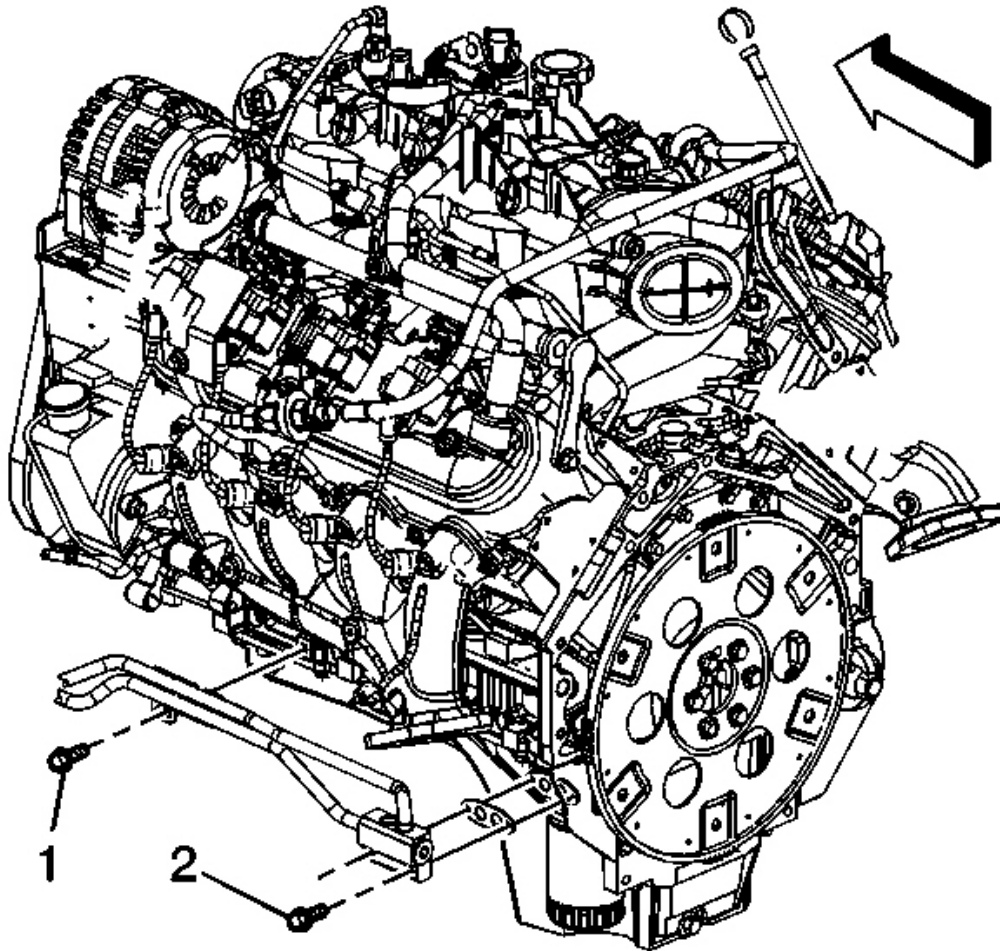

Fig. 108: Oil Cooler Hose Bracket Bolt & Adapter Bolts
Courtesy of GENERAL MOTORS CORP.

11. Position the oil cooler hose adapter.
12. Install a NEW oil cooler hose adapter gasket.
13. Install the oil cooler hose adapter bolts (2).

Tighten: Tighten the oil cooler hose adapter bolts to 12 N.m (106 lb in).

14. Install the oil cooler hose bracket bolt (1).

Tighten: Tighten the oil cooler hose bracket bolt to 25 N.m (18 lb ft).

15. Lower the vehicle.

www.4x4us.net

16. Fill the cooling system/engine block. Refer to Draining and Filling Cooling System .

www.4x4us.net

COOLANT HEATER CORD REPLACEMENT

Removal Procedure

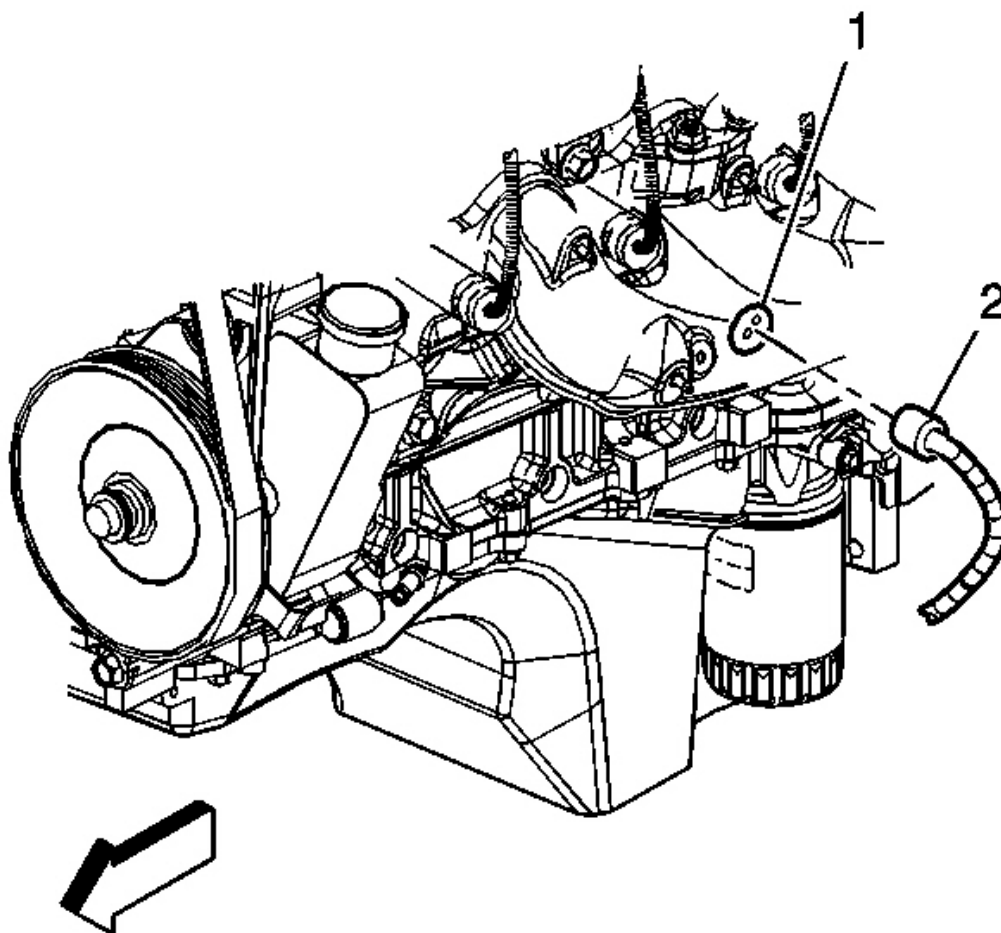

Fig. 109: Engine Coolant Heater Cord Electrical Connector & Coolant Heater
Courtesy of GENERAL MOTORS CORP.

1. Raise and suitably support the vehicle. Refer to Lifting and Jacking the Vehicle in General Information.

2. www.4x4us.net Disconnect the coolant heater electrical connector (2).

www.4x4us.net

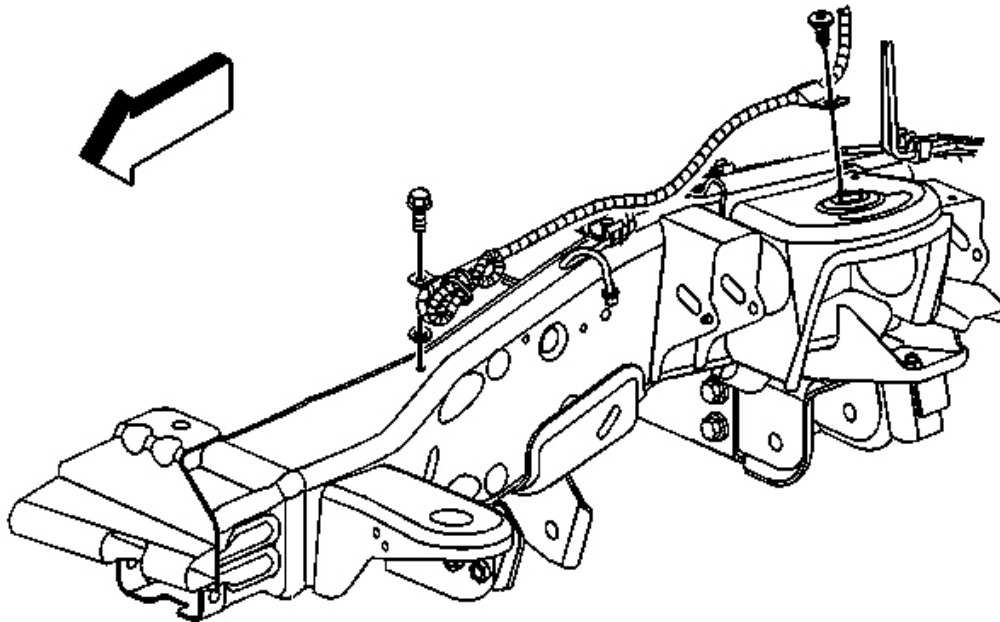

Fig. 110: Engine Coolant Heater Cord
Courtesy of GENERAL MOTORS CORP.

3. Remove the coolant heater cord retainer and bolts.
4. Remove the coolant heater cord.

Installation Procedure

NOTE: The heater cord must not touch the engine, hot pipes, manifold, or any moving parts. Route the cord to the left front of the engine compartment securing with tie straps as necessary to prevent damage.

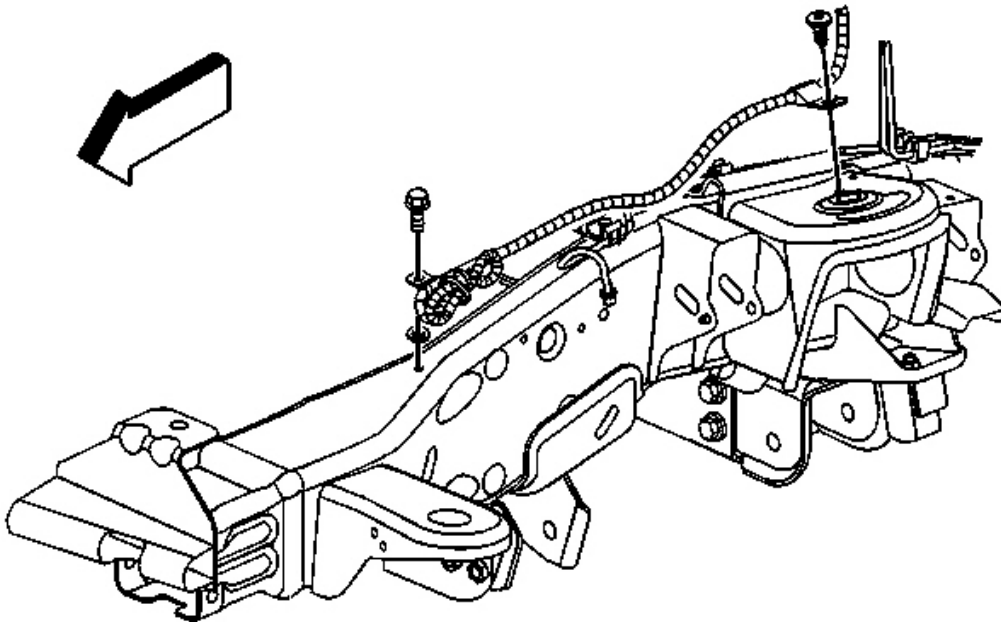

Fig. 111: Engine Coolant Heater Cord
Courtesy of GENERAL MOTORS CORP.

NOTE: Refer to Fastener Notice in Cautions and Notices.

1. Install the coolant heater cord.
2. Install the coolant heater cord bolts and retainer.

Tighten: Tighten the coolant heater cord bolts to 8 N.m (71 lb in).

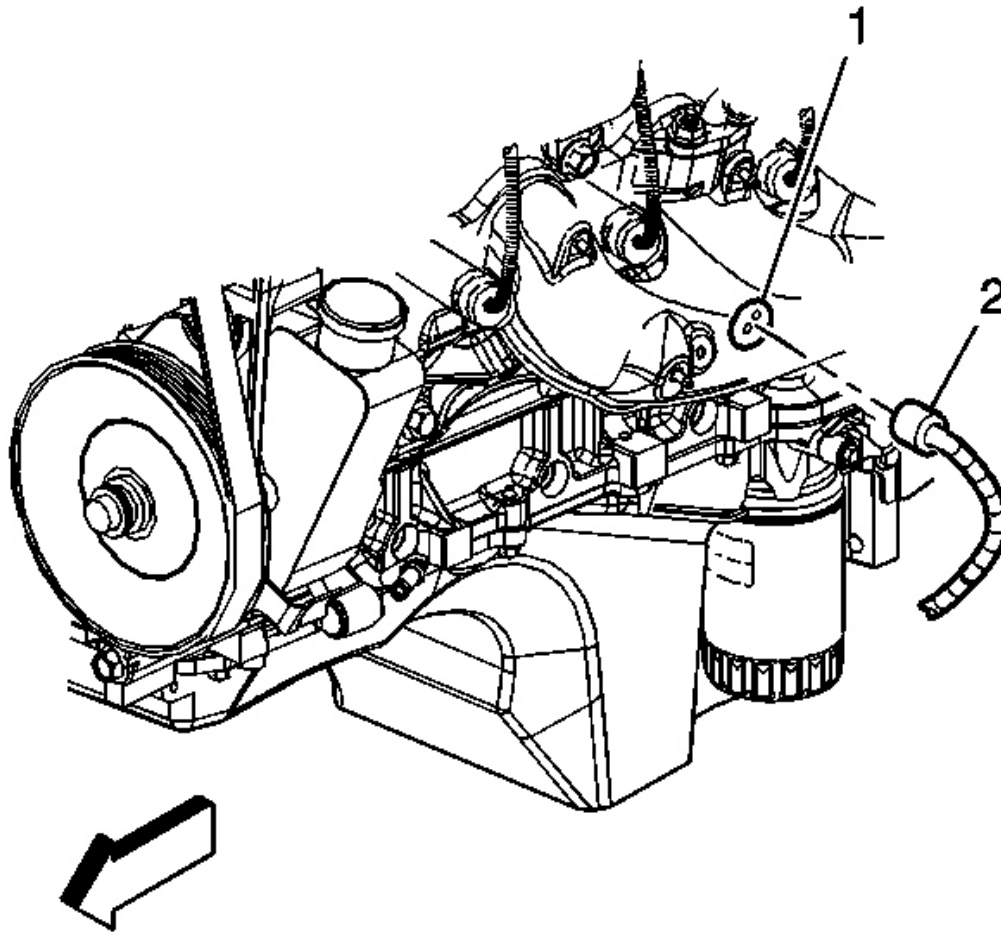

Fig. 112: Engine Coolant Heater Cord Electrical Connector & Coolant Heater
Courtesy of GENERAL MOTORS CORP.

3. Connect the coolant heater electrical connector (2).
4. Lower the vehicle.

DESCRIPTION AND OPERATION

COOLING SYSTEM DESCRIPTION AND OPERATION

Engine Coolant Indicators
www.4x4us.net

ENGINE COOLANT HOT

The instrument panel cluster (IPC) illuminates the ENGINE COOLANT HOT indicator in the message center when the IPC determines that the coolant temperature is greater than 121° C (251° F). The IPC receives a class 2 message from the powertrain control module (PCM) indicating the coolant temperature.

LOW COOLANT

The IPC illuminates the LOW COOLANT indicator in the message center when the IPC detects a low coolant level condition from the PCM. The IPC receives a class 2 message from the PCM indicating the coolant level.

ENGINE OVERHEATED

The IPC illuminates the ENGINE OVERHEATED indicator in the message center when the IPC determines that the coolant temperature is greater than 128° C (262° F). The IPC receives a class 2 message from the PCM indicating the coolant temperature.

REDUCED ENGINE POWER

The IPC illuminates the REDUCED ENGINE POWER indicator in the message center when the IPC detects a reduced engine power condition from the PCM. The IPC receives a class 2 message from the PCM requesting illumination when the engine temperature reaches 128° C (262° F).

Coolant Heater

The optional engine coolant heater (RPO K05) operates using 110-volt AC external power and is designed to warm the coolant in the engine block area for improved starting in very cold weather 29° C (20° F). The coolant heater helps reduce fuel consumption when a cold engine is warming up. The unit is equipped with a detachable AC power cord. A weather shield on the cord is provided to protect the plug when not in use.

Cooling System

The cooling system's function is to maintain an efficient engine operating temperature during all engine speeds and operating conditions. The cooling system is designed to remove approximately one-third of the heat produced by the burning of the air-fuel mixture. When the engine is cold, the coolant does not flow to the radiator until the thermostat opens. This allows the engine to warm quickly.

Cooling Cycle

Coolant is drawn from the radiator outlet and into the water pump inlet by the water pump. Coolant will then be pumped through the water pump outlet and into the engine block. In the engine block, the coolant circulates through the water pump outlet and into the engine block. In the engine block, the coolant circulates through the water jackets surrounding the cylinders, where it absorbs heat.

Some coolant is also pumped from the water pump to the heater core, then back to the water pump. This provides the passenger compartment with heat and defrost.

The coolant is then forced through the cylinder head gasket openings and into the cylinder heads. In the cylinder heads, the coolant flows through the water jackets surrounding the combustion chambers and valve seats, where it absorbs additional heat.

Coolant is also directed to the throttle body. There it circulates through passages in the casting. During initial start up, the coolant assists in warming the throttle body. During normal operating temperatures, the coolant assists in regulating the throttle body temperature.

Coolant

The engine coolant is a solution made up of a 50-50 mixture of DEX-COOL and suitable drinking water. The coolant solution carries excess heat away from the engine to the radiator, where the heat is dissipated to the atmosphere.

Radiator

The radiator is a heat exchanger. It consists of a core and two tanks. The aluminum core is a tube and fin crossflow design that extends from the inlet tank to the outlet tank. Fins are placed around the outside of the tubes to improve heat transfer to the atmosphere.

The inlet and outlet tanks are a molded, high temperature, nylon reinforced plastic material. A high temperature rubber gasket seals the tank flange edge to the aluminum core. The tanks are clamped to the core with clinch tabs. The tabs are part of the aluminum header at each end of the core.

The radiator also has a drain cock located in the bottom of the left hand tank. The drain cock unit includes the drain cock and drain cock seal.

The radiator removes heat from the coolant passing through it. The fins on the core transfer heat from the coolant passing through the tubes. As air passes between the fins, it absorbs heat and cools the coolant.

Surge Tank

The surge tank is a plastic tank with a threaded pressure cap. The tank is mounted at a point higher than all other coolant passages. The surge tank provides an air space in the cooling system that allows the coolant to expand and contract. The surge tank provides a coolant fill point and a central air bleed location.

During vehicle use, the coolant heats and expands. The increased coolant volume flows into the surge tank. As the coolant circulates, any air is allowed to bubble out. Coolant without air bubbles absorbs heat much better than coolant with bubbles.

Pressure Cap

The pressure cap seals the cooling system. It contains a blow off or pressure relief valve and a vacuum or atmospheric valve. The pressure valve is held against its seat by a spring, which protects the radiator from excessive cooling system pressure. The vacuum valve is held against its seat by a spring, which permits opening of the valve to relieve vacuum created in the cooling system as it cools off. The vacuum, if not relieved, might cause the radiator and/or coolant hoses to collapse.

The pressure cap allows cooling system pressure to build up as the temperature increases. As the pressure builds, the boiling point of the coolant increases. Engine coolant can be safely run at a temperature higher than the boiling point of the coolant at atmospheric pressure. The hotter the coolant is, the faster the heat transfers from the radiator to the cooler, passing air.

The pressure in the cooling system can get too high. When the cooling system pressure exceeds the rating of the pressure cap, it raises the pressure valve, venting the excess pressure.

As the engine cools down, the temperature of the coolant drops and a vacuum is created in the cooling system. This vacuum causes the vacuum valve to open, allowing outside air into the surge tank. This equalizes the pressure in the cooling system with atmospheric pressure, preventing the radiator and coolant hoses from collapsing.

Cooling Fan and Clutch

The engine cooling fan and clutch are driven by the crankshaft via the drive belt. The cooling fan draws air through the radiator to improve the transfer of heat from the coolant to the atmosphere. As the fan blades spin, they pull cool, outside air past the radiator core. The fan clutch drives the cooling fan. The fan clutch controls the amount of torque that is transmitted from the crankshaft to the fan blades. The clutch allows more torque to engage on the fan when the engine operating temperature increases and/or the vehicle speed is low. As the torque increases, the fan turns more quickly. The fan clutch decreases the torque applied to the cooling fan when the engine temperature decreases and/or the vehicle speed is high. As the torque decreases, the fan speed decreases.

Air Baffles and Seals

The cooling system uses deflectors, air baffles and air seals to increase cooling system capability. Deflectors are installed under the vehicle to redirect airflow beneath the vehicle and through the radiator to increase engine cooling. Air baffles are also used to direct airflow through the radiator and increase cooling capability. Air seals prevent air from bypassing the radiator and A/C condenser, and prevent recirculation of hot air for better hot weather cooling and A/C condenser performance.

Water Pump

The water pump is a centrifugal vane impeller type pump. The pump consists of a housing with coolant inlet and outlet passages and an impeller. The impeller is mounted on the pump shaft and consists of a series of flat or curved blades or vanes on a flat plate. When the impeller rotates, the coolant between the vanes is thrown outward by centrifugal force.

The impeller shaft is supported by one or more sealed bearings. The sealed bearings never need to be lubricated. Grease cannot leak out, dirt and water cannot get in as long as the seal is not damaged or worn.

The purpose of the water pump is to circulate coolant throughout the cooling system. The water pump is driven by the crankshaft via the drive belt.

Thermostat

The thermostat is a coolant flow control component. Its purpose is to help regulate the operating temperature of the engine. It utilizes a temperature sensitive wax-pellet element. The element connects to a valve through a small piston. When the element is heated, it expands and exerts pressure against the small piston. This pressure forces the valve open. As the element is cooled, it contracts. This contraction allows a spring to push the valve closed.

When the coolant temperature is below the rated thermostat opening temperature, the thermostat valve remains closed. This prevents circulation of the coolant to the radiator and allows the engine to warm up. After the coolant temperature reaches the rated thermostat opening temperature, the thermostat valve will open. The coolant is then allowed to circulate through the thermostat to the radiator where the engine heat is dissipated to the atmosphere. The thermostat also provides a restriction in the cooling system, after it has opened. This restriction creates a pressure difference which prevents cavitation at the water pump and forces coolant to circulate through the engine block.

Engine Oil Cooler

The engine oil cooler is a heat exchanger. It is located inside the left side end tank of the radiator. The engine oil temperature is controlled by the temperature of the engine coolant that surrounds the oil cooler in the radiator.

The engine oil pump, pumps the oil through the engine oil cooler line to the oil cooler. The oil then flows through the cooler where the engine coolant absorbs heat from the oil. The oil is then pumped through the oil cooler return line, to the oil filter, to the engine block oil system.

Transmission Oil Cooler

The transmission oil cooler is a heat exchanger. It is located inside the right side end tank of the radiator. The transmission fluid temperature is regulated by the temperature of the engine coolant in the radiator.

The transmission oil pump, pumps the fluid through the transmission oil cooler line to the transmission oil cooler. The fluid then flows through the cooler where the engine coolant absorbs heat from the fluid. The fluid is then pumped through the transmission oil cooler return line, to the transmission.

SPECIAL TOOLS AND EQUIPMENT

SPECIAL TOOLS

Special Tools

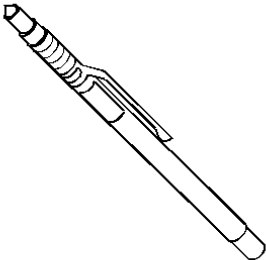
Illustration	Tool Number/Description
	J 24731 Tempil Stick
www.4x4us.net	www.4x4us.net

www.4x4us.net

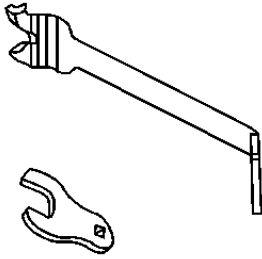

www.4x4us.net

J 46406
Fan Clutch Remover and Installer

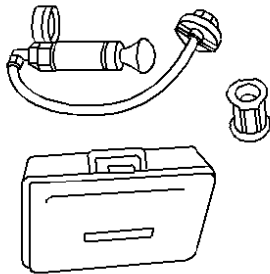

J 24460-1
Cooling System Pressure Tester

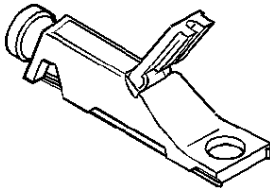

J 26568
Coolant and Battery Tester

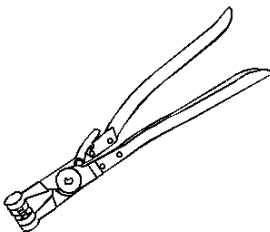

J 38185
Hose Clamp Pliers

www.4x4us.net

www.4x4us.net

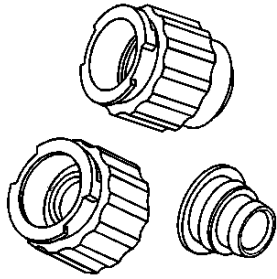

J 42401
Radiator Cap/Surge Tank Test Adapter

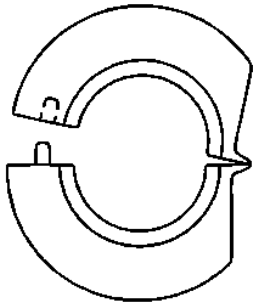

J 43181
Heater Line Quick Connect Release Tool